



**GUIDELINES FOR CLASSIFICATION OF FISHING
VESSELS**

CR CLASSIFICATION SOCIETY

February 2024

REVISION HISTORY

(This version supersedes all previous ones.)

Revision No.	Editor	Date (yyyy-mm)
001	Rules Section	2024-02

GUIDELINES FOR CLASSIFICATION OF FISHING VESSELS

CONTENTS

CHAPTER 1	GENERAL.....	1
1.1	General.....	1
1.2	Application.....	1
1.3	Class Notations	2
1.4	Definitions	2
CHAPTER 2	HULL CONSTRUCTION AND EQUIPMENT.....	4
2.1	Protection.....	4
2.2	Longitudinal Strength	5
2.3	Deck Structure	6
2.4	Shell Envelope Plating.....	6
2.5	Watertight Bulkheads	6
2.6	Stern Ramp, Cruiser and Transom Sterns	7
2.7	Local Strengthening	7
2.8	Fish Hold Bulkheads.....	7
2.9	Equipment.....	10
CHAPTER 3	MACHINERY INSTALLATIONS.....	12
3.1	General.....	12
3.2	Bilge System.....	12
3.3	Scuppers and Sanitary Discharges	17
3.4	Air Pipes and Sounding Devices in Ships.....	17
3.5	Refrigeration Systems for the Preservation of the Catch	19
3.6	Steering Gear	21
CHAPTER 4	ELECTRICAL INSTALLATIONS	23
4.1	General.....	23
4.2	General Requirements for System Design, Location and Installation	23
4.3	Lightning Protection	31
4.4	Explosion protection	32
CHAPTER 5	MISCELLANEOUS.....	33
5.1	Fishing Machinery	33

CHAPTER 1 GENERAL

1.1 General

1.1.1 The Guidelines for Classification of Fishing Vessels (hereinafter referred to as the Guidelines) provide requirements for the fishing vessels to be classed with the CR Classification Society (hereinafter referred to as the Society). Unless expressly provided otherwise, the Guidelines apply to fishing vessels of 24 m and over in length.

1.1.2 Unless in accordance with the specific provisions of the Guidelines, fishing vessels are also to comply with the relevant requirements of CR Rules for the Construction and Classification of Steel Ships (hereinafter referred to as the Rules for Steel Ships). In general, the scope of classification of fishing vessels covers the requirements for hull construction and equipment, materials and welding, machinery installations, electrical installations, refrigerated systems and relevant systems.

Apart from the scope of classification, the statutory requirements, such as stability, watertight integrity, associated seaworthiness, fire safety (including detection, protection, extinction and fighting), protection of the crew, life-saving appliances, crew accommodation, and etc., are to be in accordance with the National Authority's instruction to comply with the provisions of the Cape Town Agreement of 2012 on the Implementation of the Provisions of the 1993 Protocol relating to the Torremolinos International Convention for the Safety of Fishing Vessels, or the requirements specified by the National Authority.

For fishing vessels of 24 m in length and over but less than 45 m, it may be referred to the Safety Regulations for Fishing Vessels of 24 metres in length and above to supplement the requirements not included in the Cape Town Agreement of 2012.

Where the scope of classification and statutory overlapped each other, compliance with those statutory requirements could be deemed as meeting the corresponding requirements of the Guidelines.

1.1.3 For fishing vessels of less than 24 m in length

- (a) For fishing vessels of 12 m and over but less than 24 m in length, it may be referred to the Voluntary Guidelines for the Design, Construction and Equipment of Small Fishing Vessels (hereinafter referred to as the Voluntary Guidelines for Small Fishing Vessels).
- (b) For fishing vessels of less than 12 m in length, it may be referred to the Safety Recommendations for Decked Fishing Vessels of Less than 12 metres in Length and Undecked Fishing Vessels.

1.2 Application

1.2.1 The Guidelines provide requirements for vessels intended for fishing including fishing vessels, trawlers and stern trawlers.

1.2.2 For the purpose of the Guidelines, a fishing vessel is a ship used for fishing operations, but not equipped for trawling.

1.2.3 The scantlings and arrangements are in accordance with the requirements of Part II or Part XV of the Rules for Steel Ships. Consideration will be given to proposals for modified scantlings on ships where L is less than 24 m.

1.2.4 Special consideration may be given to fishing vessels where it is impractical to comply with the requirements of the Guidelines.

1.3 Class Notations

1.3.1 In general, ships complying with the requirements of the Guidelines will be eligible for one of the following class notations:

- (a) **Fishing Vessel.** This notation will be assigned to fishing vessels, see also Chapter 7 of Part III of the Rules for Steel Ships.
- (b) **Trawler.** This notation will be assigned to side fishing trawlers.
- (c) **Stern Trawler.** This notation will be assigned to stern fishing trawlers.

1.3.2 The requirements for classification and the assignment of class notations are given in Chapter 1 of Part I of the Rules for Steel Ships to which reference should be made.

1.4 Definitions

1.4.1 Working deck

The working deck is generally the lowest complete exposed deck above the deepest operating waterline from which fishing is undertaken.

The Society may accept a lower complete deck as a working deck provided that such a deck is situated above the deepest operating waterline.

1.4.2 The length (L) shall be taken as 96% of the total length on a waterline at 85% of the least moulded depth measured from the keel line, or as the length from the foreside of the stem to the axis of the rudder stock on that waterline, if that be greater. In vessels designed with a rake of keel the waterline on which this length is measured shall be parallel to the designed waterline.

1.4.3 The Rule Length (L_R) is the distance, in meters, on the classification waterline from the fore side of the stem to the after side of the rudder post, or to the centre of the rudder stock if there is no rudder post. L_R is to be not less than 96%, and need not be greater than 97%, of the extreme length on the classification waterline. The Rule Length, L_R , will be used to determine the scantling of the ship.

1.4.4 Breadth (B) is the greatest moulded breadth, in meters.

1.4.5 Depth (D) is measured, in meters, at the middle of the length, L from the base line to top of the deck beam at side on the uppermost continuous deck.

1.4.6 The classification waterline in single deck ships is the waterline taken perpendicular to the plane of the transverse bulkheads located at 0.85 D from the base line amidships, or at the maximum permissible operating draft amidships, whichever is the greater. In two-deck ships, it is the waterline located at the maximum permissible operating draft, but if this is unknown, it may be taken at 50 mm below the lower deck. If a load line is required by a National Authority, the classification waterline is the summer load waterline.

1.4.7 Keel line is the line parallel to the slope of the keel intersecting the top of the keel at amidships, or the line of intersection of the inside of shell plating with the keel where a bar keel is fitted.

1.4.8 Base line is a line parallel to the classification waterline and intersecting the keel line at amidships.

CHAPTER 1 GENERAL

1.4 Definitions

1.4.9 Draught (T) is the distance, in metres, between the classification waterline and the base line amidships.

1.4.10 The block coefficient (C_b) is to be taken at the classification waterline.

1.4.11 Deepest operating waterline is the waterline related to the maximum permissible operating draft.

1.4.12 The following symbols are also applicable to the Guidelines:

K = material factor, see 1.5.2(a) of Part II of the Rules for Steel Ships
 l_e = effective length of stiffening member, in meters, see 1.9.2 of Part I of the Rules for Steel Ships

s = spacing of stiffeners, in mm

s_{b_FP} = standard frame spacing for fore end structure, in mm, as follows:

Region	Bottom shell s_b	Side shell s_b
Forward of 0.05 L from the F.P	$(470 + \frac{L}{0.6})$ or 600*	$(470 + \frac{L}{0.6})$ or 600*
Between 0.05 L and 0.2 L from the F.P.	$(470 + \frac{L}{0.6})$ or 700*	$(470 + \frac{L}{0.6})$ or 700*
Between 0.2 L and 0.25 L from the F.P.	$(510 + \frac{L_2}{0.6})$	* whichever is the lesser

$L_2 = L$, but need not be taken greater than 215 m

s_{b_AP} = standard frame spacing for fore end structure, in mm, as follows:

Region	Bottom shell s_b	Side shell s_b
Aft of 0.05 L from the A.P	$(470 + \frac{L}{0.6})$ or 600*	$(470 + \frac{L}{0.6})$ or 600* below the deck next above the load waterline, or $(470 + \frac{L}{0.6})$ or 700* below the deck next above the load waterline
Between 0.05 L and 0.15 L from the A.P.	$(510 + \frac{L}{0.6})$ or 850*	$(510 + \frac{L}{0.6})$ or 850* * whichever is the lesser

s_1 = spacing of secondary stiffeners, in mm, but not less than s_b

t = thickness of plating, in mm

Z = section modulus of stiffening member, in cm^3

CHAPTER 2 HULL CONSTRUCTION AND EQUIPMENT

2.1 Protection

2.1.1 Protection of steelwork

- (a) Where wood sheathing is fitted, the material is to be of good quality, well seasoned and free from sapwood, and the thickness is to be not less than 65 mm. The plank widths should not normally exceed 150 mm. Thwartship planks are to be laid at the ends of deckhouses and at break of deck. Fastenings are to be sunk below the surface of the planking and covered with turned dowels, and the whole to be thoroughly bedded in a suitable composition. All weather decks are to be caulked and payed.
- (b) Where gutter waterways are fitted, the bar forming the inner edge of the waterway is to be not less than 7.5 mm thick.
- (c) Welded studs are to be not less than 9.5 mm diameter, and are to be coated with suitable composition before the planking is laid. Bolts used instead of studs may be 12.5 mm diameter galvanised. If the steel deck is penetrated for bolts, the deck is to be hose tested.
- (d) Where trawl winches are set back from the aft end, wear bars are to be fitted to minimise excessive wear resulting from the winch cables rubbing against the deck.

2.1.2 Protection of cargo

- (a) When a fuel oil bunker or double bottom carrying fuel oil, or a lubricating oil tank, is adjacent to a fish hold, the relevant requirements of Chapter 8 of Part II and Chapter 9 & 16 of Part XV of the Rules for Steel Ships are to be complied with.
- (b) Compartments used for the processing of fish, or for temporary storage during or while awaiting processing, need not comply with the requirements of 2.1.2(a), but the construction of the bulkheads, decks and insulation, if any, should be such as to minimise the risk of oil leakage.

2.1.3 Hull materials for refrigerated spaces

- (a) Where the minimum design temperature of the steel falls below 0°C in refrigerated spaces, in addition to the requirements of 1.5 in Part II of the Rules for Steel Ships, the grade of steel for the following items is to comply, in general, with the requirements of Table 2-1:
 - (i) Deck plating.
 - (ii) Webs of deck girders.
 - (iii) Longitudinal bulkhead strakes attached to deck.
 - (iv) Shelf plates and their face bars supporting hatch covers.
- (b) Unless a temperature gradient calculation is carried out to assess the design temperature in the items defined in 2.1.3(a), the temperature to which the steel deck may be subjected is to be assessed as shown in Table 2-2.

Table 2-1
Grades of Steel for Refrigerated Spaces with a Minimum Design Temperatures below °C

Minimum design temperature (T_D), in °C	Thickness (t), in mm	Grades of steel
$-10^{\circ}\text{C} \leq T_D < 0^{\circ}\text{C}$	$t \leq 12.5$	B / AH
	$12.5 < t \leq 25.5$	D / DH
	$25.5 < t$	E / EH
$-25^{\circ}\text{C} \leq T_D < -10^{\circ}\text{C}$	$t \leq 12.5$	D / DH
	$12.5 < t$	E / EH
$-40^{\circ}\text{C} \leq T_D < -25^{\circ}\text{C}$	$t \leq 12.5$	E / EH
	$12.5 < t$	FH / steels for low temperature service ⁽¹⁾

Note:

- (1) Steels for low temperature service refer to 4.4 in Part XI of the Rules for Steel Ships.

Table 2-2
Assessment of Deck Temperature

Arrangement	Deck temperature
(1) Deck not covered with insulation in the refrigerated space	Temperature of the refrigerated space
(2) Deck covered with insulation in the refrigerated space and not insulated on the other side	Temperature of the space on the uninsulated side
(3) Deck covered with insulation on both sides	
(a) Temperature difference no greater than 11°C	Mean of the temperatures of the spaces above and below the deck
(b) Temperature difference greater than 11°C but no greater than 33°C	Mean of the temperatures of the spaces above and below the deck less than 3°C
(c) Temperature difference greater than 33°C	Deck temperature will be specially assessed

Note:

- (1) Where one of the internal spaces concerned is not refrigerated, the temperature of the space is to be taken as 5°C.

2.2 Longitudinal Strength

2.2.1 The longitudinal strength is generally to comply with the relevant requirements of Part II, Chapter 3 or Part XV, Chapter 3 of the Rules for Steel Ships. However, the requirements of loading instruments are not applicable to trawlers and fishing vessels.

2.2.2 In addition to 2.2.1, for fishing vessels, the design still water bending moment and shear force at each transverse section along the length of hull are to be calculated from the following conditions:

- (a) Sail to the fishing ground with a full load of fuel, supplies, ice, fishing gear, etc.;
- (b) Depart the fishing ground with a full load of catches;
- (c) Arrive at the base port with a full load of catches, 10% of supplies, fuel, etc.;
- (d) 10% of the supplies, fuel, etc. and the minimum amount of catches, usually 20% of the fully loaded catches when arriving at the base port;
- (e) More dangerous loading conditions than those described above.

2.3 Deck Structure

2.3.1 Deck plating

- (a) The thickness of deck plating is to be not less than that required by 7.2 of Part III of the Rules for Steel Ships. Under the trawl winch, windlass, mast, centre and side bollards and gallows, the plating thickness is to be not less than:

$$t = (0.04L_R + 7.5), \text{ in mm}$$

where L_R is to be taken not less than 30 m.

- (b) When a raised deck is fitted, adequate scarfing is to be arranged at the step.

2.4 Shell Envelope Plating

2.4.1 The requirements of shell envelope plating are to be complied with the follows:

- (a) The thickness of the bulwark is to be not less than that required by 7.3.3 of Part III of the Rules for Steel Ships. The thickness of shell plating is to be not less than that required by Chapter 7 of Part II of the Rules for Steel Ships but in no case is it to be less than the following:

$$\text{For } L \leq 70 \text{ m, } \quad t = (5.5 + 0.033L) \sqrt{\frac{Ks_1}{s_b}}, \text{ in mm}$$

$$\text{For } L > 70 \text{ m, } \quad t = (6.5 + 0.033L) \sqrt{\frac{Ks_1}{s_b}}, \text{ in mm}$$

- (b) For single deck side trawlers the thickness derived from 2.4.1(a) is to be increased by 10%.
- (c) When nets or control wires are in contact with the ship's side, such as below the gallows in a side trawler, the side shell plating is to be increased by 40%.
- (d) Where a bar keel is fitted, the breadth of the garboard strake is to be not less than 760 mm, and the thickness is to be 10% greater than the bottom shell.
- (e) The thickness of the bottom shell plating is to be increased by 10% where intercostal girders are not fitted.
- (f) For increase to sheerstrake at the break of a raised deck, see 1.13.4 of Part II of the Rules for Steel Ships.
- (g) Cope irons are to be fitted under gallows or any other area where excessive wear could occur.

2.5 Watertight Bulkheads

2.5.1 Collision bulkheads

Consideration will be given to proposals for the collision bulkhead to be positioned further aft than 0.08 L from the fore end of the classification waterline, provided that bow damage will not result in excessive trim forward.

2.6 Stern Ramp, Cruiser and Transom Sterns

2.6.1 Stern ramp

- (a) The thickness of plating of the stern ramp is to be not less than:

$$t = 0.025 \times s \text{ mm or } 10 \text{ mm, whichever is the greater.}$$

- (b) The section modulus of stiffeners is to be not less than:

$$Z = 0.019 \times s \times l_e^2, \text{ in cm}^3$$

2.6.2 Cruiser and transom sterns

Cruiser and transom sterns are to have frames of the size required for peaks, and are to be additionally stiffened by web frames when required.

2.7 Local Strengthening

2.7.1 Trawler

Oblique half-round bar rubbing strakes are to be provided from the top edge of the bulwark wall to the outer side of the vessel within 0.3 m below the maximum waterline, at least 1 m to the stern and 2 m to the tail of the screen frame, with a spacing not over 400 mm. If the profile indentation below the working deck is great, the rubbing strake can only be provided to sites with an indentation of 400 mm compared to working deck.

2.7.2 The thickness of the shell plating where the purse seine is installed is to be increased by 1 mm or doubled within the appropriate range.

2.7.3 The thicknesses of the wrapper sheet at the hub and that of the shell plating of multiple propeller stern frame arm at the fixing position are not to be less than 1.5 times of the thickness of the shell plating at the end. But the thickening is not necessary to be greater than 4 mm.

2.7.4 The shell plating in way of hawse pipe and one plate below or the shell plating from the head to below the anchor are to be increased in thickness or to be fitted with doubler plates.

2.8 Fish Hold Bulkheads

2.8.1 General

Where portable fish hold divisions are fitted, they are to be clearly indicated on the drawings submitted for review. Every portable fish hold division is to extend from the bottom of the hold to the deck.

2.8.2 Uprights

The section modulus of steel uprights (see Fig. 2-1) is not to be less than that obtained from the following equation.

$$SM = 4psbh^2 \text{ , in cm}^3$$

where

- s = maximum transverse spacing between supports in m
 b = maximum longitudinal spacing between supports in m
 h = maximum unsupported span of the stanchion in m
 p = density of cargo in metric tons/m³

Where the uprights are permanent and welded attachments are provided at both ends, reduced scantlings can be considered on the end connections.

Where the uprights are constructed of aluminum, wood or other material, the scantlings will be specially considered. Due consideration is to be given for material strength and isolation of dissimilar metals.

2.8.3 Portable Fish Hold Division

(a) Wooden Boards

The thickness of portable wooden boards (see Fig. 2-1) in centimeters is to be obtained from the following equations:

(i) Horizontal boards

$$t = 2.83\sqrt{psb^2} \text{ , in cm}$$

(ii) Vertical boards

$$t = 1.9\sqrt{psl^2} \text{ , in cm}$$

where

- t = thickness of wooden divisions, in cm
 l = vertical span of wooden divisions, in cm

p , s and b are as defined in 2.8.2.

The formulae are applicable to longitudinal divisions. Where the divisions are athwartships the formulae should be modified by interchanging s and b . The thickness used may be rounded off to the nearest 3 mm of the nearest standard thickness. The timber used is to be of durable quality, of a type and grade that has proved satisfactory for fish-hold divisions and the actual finished thickness of boards should be those derived from the equations. The thickness of the boards made of good quality hardwood may be reduced by 12.5%.

(b) Metallic Boards

The section modulus of portable metallic boards is not to be less than that obtained from the following equation for horizontal or vertical members.

$$SM = 4kpasb^2 \text{ , in cm}^3$$

where

- a = width of metallic board, in m

- l = unsupported span of vertical boards, in m
- k = 1 for steel
= 0.9 (Q_o) for aluminum
- Q_o = $65/(Y_{al} + U_{al})$
- U_{al} = minimum ultimate strength of the welded aluminum alloy under consideration, in kg/mm^2
- Y_{al} = minimum yield strength of the welded aluminum alloy under consideration at 0.2% offset in a 254 mm gauge length, in kg/mm^2

p , s and b are as defined in 2.8.2.

The formulae are applicable to longitudinal divisions. Where the divisions are athwartships the formulae should be modified by interchanging s and b .

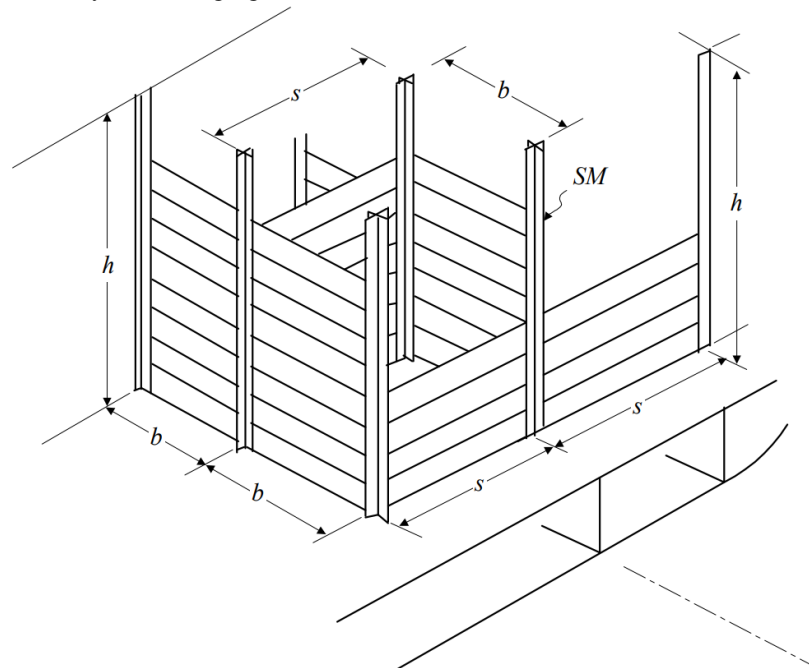

Fig. 2-1
Horizontal Wood Boards – Steel Uprights

2.9 Equipment

2.9.1 The characteristics of anchors, chain, wires, towlines and mooring lines should be determined in accordance with the attached table, based on an equipment number "EN" as follows.

$$EN = \Delta^{2/3} + 2B \left(a + \sum h_j \right) + 0.1A$$

Where:

- Δ = moulded displacement, in tonnes, to the maximum design waterline.
- B = breadth, in m, as defined in 1.4.4
- a = distance, in m, from the maximum design waterline to the upper edge of the uppermost complete deck at side amidships.
- h_j = height, in m, on the centreline of each tier of deckhouses having a breadth greater than $B/4$. For the lowest tier h_j should be measured at centreline from the upper deck or from a notional deck line where there is a local discontinuity in the upper deck. When calculating h_j sheer and trim should be ignored.
- A = area, in m^2 , in profile view of the hull, within L as defined in 1.4.2 and of superstructures and deckhouses above the maximum design waterline having a width greater than $B/4$. Screens and bulwarks more than 1.5 m in height should be regarded as parts of deckhouses when determining h_j and A .

The characteristics of anchors, chain, wires, towlines and mooring lines, based on an equipment number "EN", should be in accordance with the following table :

CHAPTER 2 HULL CONSTRUCTION AND EQUIPMENT

2.9 Equipment

Equipment number		Stockless bower anchors		Stud link chain cables for bower anchors			Towline		Mooring lines	
Exceeding	Not exceeding	Number	Weight per anchor (kg)	Total length (m)	Diameter (mm)		Minimum length of each line (m)	Minimum breaking strength (kN)	Minimum length of each line (m)	Minimum breaking strength (kN)
					Mild steel	Special quality steel				
50	60	2	120	192.5	12.5	-	180	98	60	34
60	70	2	140	192.5	12.5	-	180	98	80	34
70	80	2	160	220	14	12.5	180	98	100	37
80	90	2	180	220	14	12.5	180	98	100	37
90	100	2	210	220	16	14	180	98	110	39
100	110	2	240	220	16	14	180	98	110	39
110	120	2	270	247.5	17.5	16	180	98	110	44
120	130	2	300	247.5	17.5	16	180	98	110	44
130	140	2	340	275	19	17.5	180	98	120	49
140	150	2	390	275	19	17.5	180	98	120	49
150	175	2	480	275	22	19	180	98	120	54
175	205	2	570	302.5	24	19	180	112	120	59
205	240	2	660	302.5	26	22	180	129	120	64
240	280	2	780	330	28	24	180	150	120	69
280	320	2	900	357.5	30	26	180	174	140	74
320	360	2	1020	357.5	32	28	180	207	140	78
360	400	2	1140	385	34	30	180	224	140	88
400	450	2	1290	385	36	32	180	250	140	98
450	500	2	1440	412.5	38	34	180	277	140	108
500	550	2	1590	412.5	40	34	180	306	160	123
550	600	2	1740	440	42	36	180	338	160	128
600	660	2	1920	440	44	38	180	371	160	132
660	720	2	2100	440	46	40	180	406	160	137

CHAPTER 3 MACHINERY INSTALLATIONS

3.1 General

3.1.1 Application

- (a) Machinery systems fitted on fishing vessels of 24 m and over in length are to comply with the relevant sections of Part IV & VI of the Rules for Steel Ships, with the exception of the following systems:
- bilge system
 - scuppers and sanitary discharges
 - air pipes and sounding devices
 - refrigerating installations
 - steering gear,
- for which substitutive requirements are provided in this Chapter.
- (b) This Chapter does not cover the design and performances of the fishing equipment. However, the piping systems and pressure vessels serving the fishing equipment are required to comply with the relevant Sections of Part V & VI of the Rules for Steel Ships.

3.2 Bilge System

3.2.1 General

(a) Application

The following provisions supersede those given in Part VI of the Rules for Steel Ships.

(b) Principle

- (i) Fishing vessels are to be provided with an efficient bilge pumping system capable of pumping from and draining, under all practical conditions, any watertight compartment other than spaces exclusively intended for the carriage of fresh water, water ballast or fuel oil, for which other efficient means of pumping are to be provided.
- (ii) In fishing vessels where fishing handling or processing may cause quantities of water to accumulate in enclosed spaces, adequate drainage is to be provided.
- (iii) The bilge pumping system is to consist of pumps connected to a bilge main line so arranged as to allow the draining of all spaces mentioned in 3.2.1(b)(i) above.
- (iv) Bilge pumping arrangement may be dispensed with in particular compartments where no equipment nor openings are likely to leak.
- (v) Where expressly permitted, some small compartments may be drained by means of hand pumps.
- (vi) Bilge and ballast systems are to be so designed as to prevent the possibility of water passing from the sea and from water ballast spaces into the cargo and machinery spaces, or from one compartment to another. Provisions are to be made to prevent any space having bilge and ballast connections being inadvertently flooded from the sea when containing cargo, or being discharged through the bilge system when containing water ballast.

- (vii) Where there are common valves between bilge and fire fighting lines, they are to have a locked device on his handwheels in order to avoid the discharge of bilge water into the fighting circuit.

3.2.2 Design of the bilge system

(a) General

- (i) All suction pipes up to the connection with the bilge pumps are to be independent from any other piping system of the ship.
- (ii) Non-return valves are to be fitted on:
 - direct and emergency suction in machinery spaces
 - the pipe connections to bilge distribution boxes
 - the suction of pumps having also connections from the sea or from compartments normally intended to contain liquid
 - the direct suction connected to independent bilge pumps, where required.
- (iii) All compartments are to be provided with at least one suction on each side. However, in the case of short and narrow compartments, a single suction ensuring an efficient draining may be accepted.

(b) Draining of machinery spaces

- (i) Machinery spaces of ships with double bottom, or where the rise of floor is less than 5°, are to be provided on each side with one bilge suction connected to the bilge main.
- (ii) Machinery spaces of ships without double bottom, or where the rise of floor exceeds 5°, may be provided with only one bilge suction located in the centreline and connected to the bilge main.
- (iii) In addition to the bilge suction required in items 3.2.2(b)(i)&(ii) above, machinery spaces are to be provided with a direct suction, which is to be led direct to an independent power bilge pump and so arranged that it can be used independently of the bilge main.

(c) Emergency bilge suction

- (i) The emergency bilge suction is to be led directly from the drainage level of the machinery space to the greater capacity sea water pump. Its capacity is to be at least equal to the required capacity of each bilge pump as determined in 3.2.3(d).
- (ii) The emergency bilge suction is to be located at the lowest possible level in the machinery spaces.
- (iii) The diameter of emergency bilge suction pipes is to be at least the diameter of the suction connected to of the sea water pump in normal operation.
- (iv) The high of the hand-wheels of the non-return valves controlling emergency bilge suction are to rise at least 450 mm above the manoeuvring floor.
- (v) If the requirement mentioned in (iv) above can not be verified, the height of the hand-wheels of the non-return valves is to be the minimum height to permit the easy operation of the valve.

(d) Draining of holds

- (i) Holds of ships with double bottom, or where the rise of floor is less than 5°, are to be provided on each side with one bilge suction connected to the bilge main.
- (ii) Holds of ships without double bottom, or where the rise of floor exceeds 5°, may be provided with only one bilge suction located in the centreline and connected to the bilge main.
- (iii) Holds greater than 30 m in length, bilge suction are to be provided in the fore and aft ends and connected to the bilge main.

(e) Draining of refrigerated spaces

Refrigerated spaces are to be provided with drainage arrangement allowing the continuous drainage of condensates.

(f) Draining of fore and aft peaks

- (i) Fore and aft peaks, where not used as tanks, are to be fitted with a bilge suction connected to the bilge main. Passage through the collision bulkhead is to comply with 3.2.5(b).
- (ii) Peaks of small dimensions may be drained by means of a hand pump provided that the suction lift is well within the capacity of the pump and in no case exceeds 7.3 m.

(g) Draining of double bottom compartments

Double bottom compartments, where not used as tanks, are to be provided with bilge suctions. Their number and location are to comply with the provisions of 3.2.2(d). However, if deemed acceptable by the Society, the cofferdams fitted between two different compartments of the double bottom may be provided with one bilge suction only.

(h) Draining of other compartments

- (i) Provision is to be made for the drainage of chain lockers and other fore spaces by means of hand or power pump suctions or hydraulic ejectors.
- (ii) Provision is to be made for the drainage of the steering gear compartment and other spaces located above the aft peak by means of suctions connected to the bilge main or by means of hand pumps or hydraulic ejectors.
- (iii) These spaces may, however, be drained by means of scuppers discharging to the shaft tunnel, provided that the discharge pipes are fitted with self-closing valves situated in easily visible and accessible positions.
- (iv) Fish processing spaces are to be fitted with drainage means, the capacity of which is four times the normal feedwater flow in the space.

3.2.3 Bilge pumps

(a) Number and arrangement of pumps

- (i) Fishing vessels are to be provided with at least two power bilge pumps of the self-priming type connected to the bilge main and having the capacity required in 3.2.3(d). One of these pumps may be driven by the propulsion machinery.
- (ii) Each bilge pump may be replaced by two or more pumps, provided that they are connected to the bilge main and that their total capacity is not less than that required in 3.2.3(d).
- (iii) One of the bilge pumps required in 3.2.3(a)(i) above may be replaced by a hydraulic ejector having the capacity required in 3.2.3(d) and connected to a high pressure water pump.
- (iv) Where permitted, hand pumps are to be operable from an easily accessible position above the load waterline.

(b) Location of bilge pumps

Bilge pumps are to be located on the aft side of the collision bulkhead. This may not apply to those pumps only used for the draining of the spaces located on the fore side of the collision bulkhead.

(c) Use of pumps intended for other duties

- (i) Pumps used for sanitary service, general service or ballast may be considered as independent bilge pumps provided that:
 - they have the capacity required in 3.2.3(d)
 - they are of the self-priming type

- they are connected to the bilge system.
- (ii) Non-return valves are to be provided in accordance with 3.2.2(a)(ii).
- (d) Bilge pump capacity
 - (i) The water speed V in the bilge main and the capacity Q of each bilge pump are to be not less than the values given in Table 3-1.
 - (ii) If the capacity of one of the pumps is less than the rule capacity, the deficiency may be compensated by an excess capacity of the other pumps. Such deficiency is, however, not to exceed 30% of the rule capacity.

Table 3-1
Water Speed and Pump Capacity

Ship's length	$L < 35$	$L \geq 35$
Water speed	$V = 1.22$	$V = 2$
Pump capacity	$Q = 0.00345 d^2$	$Q = 0.00565 d^2$
L : Length of the ship, in m V : Minimum water speed in the bilge main, in m/s Q : Minimum capacity of each pump, in m ³ /h d : Internal diameter of the bilge main, in mm, as defined in 3.2.4(a).		

3.2.4 Size of bilge pipes

- (a) Bilge main line
 - (i) The diameter of the bilge main is to be calculated according to the following formula:

$$d = 25 + 1.68\sqrt{L(B + D)}$$
 without being less than 50 mm,
 where:
 - d : Internal diameter of the bilge main, in mm
 - L : Length of the ship between perpendiculars, in m
 - B : Breadth of the ship, in m
 - D : Depth of the ship, measured up to the bulkhead deck, in m.
 - (ii) The actual internal diameter may be rounded off. The nearest standard size is in no case to be more than 5 mm smaller than that obtained from the formula given in 3.2.4(a)(i) above.

- (b) Branch bilge suction pipes
 - (i) The diameter of the pipes situated between the distribution boxes and the suctions in the various spaces (holds, machinery space, etc) is to be calculated according to the following formulae:

$$d_1 = 25 + 2.16\sqrt{L_1(B + D)}$$

without being less than 50 mm,
 where:

- d_1 : Internal diameter of the bilge main, in mm
 L_1 : Length of the space considered, in m
 B : Breadth of the ship, in m
 D : Depth of the ship, measured up to the bulkhead deck, in m.

- (ii) The actual internal diameter may be rounded off. The nearest standard size is in no case to be more than 5 mm smaller than that obtained from the formula given in item 3.2.4(b)(i) above.

3.2.5 Bilge piping arrangement

- (a) Passage through double bottom compartments and tanks

Bilge pipes are not to pass through double bottom compartments or tanks unless they are enclosed in appropriate pipe tunnels.

Where this is not practicable, pipes are to be of reinforced thickness as per Table VI 2-3 of the Rules for Steel Ships and made of either one piece or several pieces assembled by welding or by reinforced flanges.

- (b) Passage through the collision bulkhead

- (i) A maximum of two pipes may pass through the collision bulkhead below the freeboard deck, unless otherwise justified. Such pipes are to be fitted with suitable valves operable from above the freeboard deck and the valve chest is to be secured at the bulkhead inside the fore peak. Such valves may be fitted on the after side of the collision bulkhead provided that they are readily accessible under all service conditions and the space in which they are located is not a cargo space. All valves are to be of steel, bronze or other approved ductile material. Valves of ordinary cast iron or similar material are not acceptable.

- (ii) The remote operation device of the valve referred to in 3.2.5(b)(i) is to include an indicator to show whether the valve is open or shut.

- (c) Bilge suction in machinery spaces and shaft tunnels

In machinery spaces and shaft tunnels, the termination pipes of the bilge suction are to be straight and vertical and are to be led to mud boxes so arranged as to be easily inspected and cleaned. The lower end of the termination pipe is not to be fitted with a strum box.

- (d) Bilge suction in other compartments

In compartments other than machinery spaces and shaft tunnels, the open ends of bilge suction pipes are to be fitted with strum boxes or strainers having holes not more than 10 mm in diameter. The total area of such holes is not to be less than twice the required cross-section of the suction pipe.

- (e) Bilge alarms

Propulsion machinery spaces are to be fitted with a bilge level sensor capable of indicating water ingress in those spaces at the bridge by means of a visual and audible alarm.

3.2.6 Materials

- (a) All bilge pipes used in fuel storage tanks or in boiler or machinery spaces, including spaces in which oil-setting tanks or fuel oil pumping units are situated, are to be of steel or other suitable material non-sensitive to heat.

3.3 Scuppers and Sanitary Discharges

3.3.1 Principle

- (a) Scuppers, sufficient in number and suitable in size, are to be provided to permit the drainage of water likely to accumulate in the spaces which are not located in the ship's bottom.
- (b) The number of scuppers and sanitary discharge openings in the shell plating is to be reduced to a minimum, either by making each discharge serve as many as possible of the sanitary and other pipes, or in any other satisfactory manner.

3.3.2 General

- (a) Discharges led through the shell either from spaces below the working deck or from within enclosed superstructures or deckhouses on the working deck fitted with weathertight doors are to be fitted with accessible means for preventing water from passing inboard.
- (b) Each separate discharge is to have an automatic non-return valve with a positive means of closing it from an accessible position, except when:
 - satisfactory analysis is submitted to the Society, demonstrating that the entry of water into the ship through the opening is not likely to lead to dangerous flooding, and
 - the piping is of reinforced thickness as per Table VI 2-3 of the Rules for Steel Ships.
- (c) The means for operating the positive action valve is to be provided with an indicator showing whether the valve is open or closed.

3.3.3 Discharges through manned machinery spaces

- (a) In manned machinery spaces, main and auxiliary discharges essential for the operation of machinery may be controlled locally. The controls are to be accessible and are to be provided with indicators showing whether the valves are open or closed.

3.3.4 Materials

- (a) Fittings attached to the shell and the valves required in 3.3.2(b) are to be of steel, bronze or other ductile material.
- (b) All pipes between the shell and the valves are to be of steel. However, in spaces other than machinery spaces of ships constructed of material other than steel, the use of other materials may be permitted, subject to special consideration by the Society.

3.3.5 Scupper and discharge pipes are to be complied with the requirements of 22.1.9 of Part II of the Rules for Steel Ships.

3.4 Air Pipes and Sounding Devices in Ships

3.4.1 Air pipes

(a) General

Air pipes are to be fitted to all spaces which are not fitted with alternative ventilation arrangements.

Air pipes are to be so arranged and the upper part of compartments so designed that air or gas likely to accumulate in the said compartments can freely evacuate.

When only one air pipe is provided, it is not to be used as filling pipe.

(b) Exposed parts of air pipes

Where air pipes to tanks and void spaces below deck extend above the working or the superstructure decks, the exposed parts of the pipes are to be of strength equivalent to the adjacent structures and fitted with the appropriate protection.

(c) Means of closing

Openings of air pipes are to be provided with means of closing, permanently attached to the pipe or adjacent structure.

(d) Special arrangements for air pipes of flammable oil tanks

(i) Air pipes from fuel oil and thermal oil tanks are to discharge to a safe position on the open deck where no danger will be incurred from issuing oil or gases.

Where fitted, wire gauze diaphragms are to be of corrosion resistant material and readily removable for cleaning and replacement. The clear area of such diaphragms is not to be less than the cross-sectional area of the pipe.

(ii) Air pipes of lubricating or hydraulic oil storage tanks not subject to flooding in the event of hull damage may be led to machinery spaces, provided that in the case of overflowing the oil cannot come into contact with electrical equipment, hot surfaces or other sources of ignition.

(iii) The location and arrangement of vent pipes for fuel oil service, settling and lubrication oil tanks are to be such that, in the event of a broken vent pipe, there is no risk of ingress of seawater or rainwater.

(iv) Where seawater or rainwater may enter fuel oil service, settling and lubrication oil tanks through broken air pipes, arrangements such as water traps with:

- automatic draining, or
- alarm for water accumulation,

are to be provided.

(e) Construction of air pipes

(i) Where air pipes to ballast and other tanks extend above the freeboard deck or superstructure deck, the exposed parts of the pipes are to be of substantial construction, with a minimum wall thickness of at least:

- 6.0 mm for pipes of 80 mm or smaller external diameter,
- 8.5 mm for pipes of 165 mm or greater external diameter.

Intermediate minimum thicknesses may be determined by linear interpolation.

(ii) Air pipes with height exceeding 900 mm are to be additionally supported.

(iii) In each compartment likely to be pumped up, and where no overflow pipe is provided, the total cross-sectional area of air pipes is not to be less than 1.25 times the cross-sectional area of the corresponding filling pipes.

(iv) The internal diameter of air pipes is not to be less than 50 mm, except for tanks of less than 2 m³.

3.4.2 Sounding and level gauging devices

(a) General

Sounding devices are to be fitted:

- to the bilges of those compartments which are not readily accessible at all times during voyages, and
- to all tanks and cofferdams.

(b) Termination of sounding pipes

Where sounding pipes are fitted, their upper ends are to extend to a readily accessible position and, where practicable, above the working deck.

(c) Means of closing

The openings of the sounding pipes are to be provided with permanently attached means of closing. Sounding pipes which are not extended above the working deck are to be fitted with automatic self-closing devices.

(d) Special arrangements for sounding pipes of flammable oil tanks

Where tanks containing fuel oil or hydraulic oil are fitted with sounding pipes, their upper ends are to terminate in safe positions and are to be fitted with suitable means of closure.

Gauges made of heat-resistant glass of substantial thickness and protected with a metal case may be used, provided that automatic closing valves are fitted. The level gauge is to be of an approved type. Other means of ascertaining the amount of oil contained in the tank may be permitted provided their failure or overfilling will not permit release of fuel.

(e) Construction of sounding pipes

- (i) Sounding pipes are normally to be straight. If it is necessary to provide bends in such pipes, the curvature is to be as small as possible to permit the ready passage of the sounding apparatus.
- (ii) Bent portions of sounding pipes are to have reinforced thickness and be suitably supported.
- (iii) The internal diameter of sounding pipes is not to be less than 32 mm. Where sounding pipes pass through refrigerated spaces, or through the insulation of refrigerated spaces in which the temperature may be below 0 °C, their internal diameter is to be at least 60 mm.
- (iv) Doubling plates are to be placed under the lower ends of sounding pipes in order to prevent damage to the hull. When sounding pipes with closed lower ends are used, the closing plate is to have reinforced scantlings.

3.5 Refrigeration Systems for the Preservation of the Catch

3.5.1 General

- (a) The refrigeration systems of fishing vessels are to be complied with the relevant requirements specified in Part X of the Rules for Steel Ships. Classification symbol **RMS** is to be assigned to the refrigerating machinery including hold insulation and working condition which complies with the Part X of the Rules for Steel Ships.
- (b) Refrigeration systems are to be so designed, constructed, tested and installed as to take account of the safety of the system and also the emission of chlorofluorocarbons (CFCs) or any other ozone-depleting substances from the refrigerant held in quantities or concentrations which are hazardous to human health or to the environment.
- (c) Methylchloride or CFCs whose ozone-depleting potential is higher than 5% of CFC-11 are not to be used as refrigerants.

- (d) Adequate guidance for the safe operation of the refrigeration system and emergency procedures are to be provided by means of suitable notices displayed on board the ship.

3.5.2 Design of refrigeration systems

- (a) Refrigeration systems are to be adequately protected against vibration, shock, expansion, shrinkage, etc. and are to be provided with an automatic safety control device to prevent a dangerous rise in temperature and pressure.
- (b) Refrigeration systems in which toxic or flammable refrigerants are used are to be provided with drainage devices leading to a place where the refrigerant presents no danger to the ship or to persons on board.

3.5.3 Arrangement of the refrigerating machinery spaces and refrigerating rooms

- (a) Separation of spaces
 - (i) Any space containing refrigerating machinery, including condensers and gas tanks utilising toxic refrigerants, is to be separated from any adjacent space by gas-tight bulkheads. Any space containing refrigerating machinery, including condensers and gas tanks utilizing toxic refrigerants, is to be fitted with a leak detection system having an indicator outside the space adjacent to the entrance and is to be provided with an independent ventilation system and a water-spraying system.
 - (ii) For fishing vessels under 55 m in length, ammonia plants are allowed to be located in the machinery space provided that they comply with the provisions as follows:
 - (1) When installation of an ammonia plant is allowed in the engine room, the area where the ammonia machinery is installed is to be served by a hood with a negative pressure ventilation system, having a capacity of not less than 30 air changes per hour, independent from any other ship ventilation system, so as to prevent any leakage of ammonia from dissipating into other areas in the engine room.
 - (2) A water spray system is to be provided for the said area, covering the whole ammonia machinery and operable locally and from the outside of the engine room.
 - (3) A fixed ammonia detector system with audible and visual alarms inside and outside the space. This system is also to stop the compressor when a dangerous gas concentration is reached.
 - (4) Ammonia piping is not to pass through accommodation spaces.
 - (iii) Arrangements for compartments housing machinery using ammonia are to be complied with the requirements 3.2 of Part X of the Rules for Steel Ships.

(b) Exits from spaces

In refrigerating machinery spaces and refrigerating rooms, alarms are to be connected to the wheelhouse or control stations or escape exits to prevent persons being trapped. At least one exit from each such space is to be capable of being opened from the inside. Where practicable, exits from spaces containing refrigerating machinery using toxic or flammable gas are not to lead directly into accommodation spaces.

3.5.4 Breathing apparatus

- (a) Where any refrigerant harmful to persons is used in a refrigeration system, at least two sets of breathing apparatus are to be provided, one of which is to be placed in a position not likely to become inaccessible in the event of leakage of refrigerant.

Breathing apparatus provided as part of the ship's fire-fighting equipment may be considered as meeting all or part of this provision provided its location meets both purposes. Where self-contained breathing apparatus is used, spare cylinders are to be provided. Alternative arrangement authorized by the Administration concerned may be accepted.

3.6 Steering Gear

3.6.1 Application

- (a) The provisions of this Section apply in addition to those of 4.2 of Part IV of the Rules for Steel Ships, with the exception of Sub-Sections 4.2.1 to 4.2.4, 4.2.6 and 4.2.8 of Part IV of the Rules for Steel Ships.

3.6.2 General

- (a) Unless expressly provided otherwise, every ship is to be provided with main steering gear and auxiliary steering gear to the satisfaction of the Society.

3.6.3 Strength, performance and power operation of the steering gear

(a) Main steering gear

The main steering gear and rudder stock are to be:

- (i) of adequate strength and capable of steering the ship at maximum ahead service speed, which is to be demonstrated
- (ii) capable of putting the rudder over from 35° on one side to 35° on the other side with the ship at its deepest seagoing draught and running ahead at maximum ahead service speed and, under the same conditions, from 35° on either side to 30° on the other side in not more than 28 s
- (iii) operated by power where necessary to fulfil the requirements of 3.6.3(a)(ii), and
- (iv) so designed that they will not be damaged at maximum astern speed; however, this design requirement need not be proved by trials at maximum astern speed and maximum rudder angle.

(b) Auxiliary steering gear

The auxiliary steering gear is to be:

- (i) of adequate strength and sufficient to steer the ship at navigable speed and capable of being brought speedily into action in an emergency,
- (ii) capable of putting the rudder over from 15° on one side to 15° on the other side in not more than 60s with the ship at its deepest seagoing draught and running ahead at one half of the maximum ahead service speed or 7 knots, whichever is the greater, and
- (iii) operated by power where necessary to meet the requirements of 3.6.3(b)(ii).

(c) Hand operation

Hand operation of steering gear is permitted when it requires an effort less than 160 N.

3.6.4 Control of the steering gear

(a) Control of the main steering gear

- (i) Control of the main steering gear is to be provided on the navigation bridge
- (ii) Where the main steering gear is arranged in accordance with 3.6.5(b), two independent control systems are to be provided, both operable from the navigation bridge. This does not require duplication of the steering wheel or steering lever.

(b) Control of the auxiliary steering gear

- (i) Control of the auxiliary steering gear is to be provided on the navigation bridge, in the steering gear compartment or in another suitable position.
- (ii) If the auxiliary steering gear is power operated, its control system is also to be independent of that of the main steering gear

3.6.5 Availability

- (a) Arrangement of main and auxiliary means for actuating the rudder

The main steering gear and the auxiliary means for actuating the rudder are to be arranged so that a single failure in one will not render the other inoperative.

- (b) Omission of the auxiliary steering gear

Where the main steering gear comprises two or more identical power units, auxiliary steering gear need not be fitted, provided that the main steering gear is capable of operating the rudder:

- (i) as required in 3.6.3(a)(ii), while operating with all power units
- (ii) as required in 3.6.3(b)(ii), while any one of the power units is out of operation

- (c) Hydraulic power supply

Hydraulic power installations supplying steering gear may also supply other equipment at the same time provided that the operation of the steering gear is not affected:

- (i) by the operation of this equipment, or
- (ii) by any failure of this equipment or of its hydraulic supply piping.

CHAPTER 4 ELECTRICAL INSTALLATIONS

4.1 General

4.1.1 Application

- (a) The requirements of Part VII of the Rules for Steel Ships apply to fishing vessels, except for the requirements of the following items, which will be replaced by those contained in this chapter:
 - (i) Main Source and Emergency Source of Electrical Power
 - (ii) System Design of Distribution and Circuit Protection
 - (iii) Protection of Electrical Enclosures
 - (iv) Electrical Equipment for Use in Explosive Gas Atmospheres
 - (v) Switchboards and Mounted Equipment

4.2 General Requirements for System Design, Location and Installation

4.2.1 Design and construction

- (a) The design and construction of electrical installations are to be such as to provide:
 - (i) the services necessary to maintain the ship in normal operational and habitable conditions without having recourse to an emergency source of power,
 - (ii) the services listed in 4.2.4(b) when failure of the main source of electrical power occurs, and
 - (iii) protection of the crew and ship from electrical hazards.

4.2.2 Distribution

- (a) Supply systems

Distribution systems given in Chapter 2 of Part VII of the Rules for Steel Ships may be used on board of fishing vessels. Where the length of ship is less than 24 m, on DC installations, two-wire systems with one pole earthed may be used.
- (b) General requirements given in 2.1.1 (c) of Chapter 2 of Part VII of the Rules for Steel Ships is applicable to fishing vessels. In addition, where length is less than 24 m, every conductor carrying the current from a circuit to the hull is to have the same cross section as the corresponding insulated conductor. In DC installations, one pole of generator and of supplied appliances is to be earthed in readily accessible places.
- (c) The hull return system of distribution is not to be used for power, heating or lighting in ships of 75 m of length and over.
- (d) The requirement in 4.2.2(c) does not preclude, under conditions approved by the Society, the use of:
 - (i) Impressed current cathodic protection systems for external hull protection.
 - (ii) Limited and locally earthed systems, provided that any possible resulting current does not flow directly through any dangerous spaces.

- (iii) Insulation monitoring systems provided the circulation current does not exceed 30 mA under any circumstances.
- (e) Where the hull return system is used, all final subcircuits (all circuits fitted after the last protective device) are to be two-wire and special precautions are to be taken to the satisfaction of the Society.

4.2.3 Main source of electrical power

- (a) Where the electrical power constitutes the only means of maintaining auxiliary services essential for the propulsion and safety of the ship, a main source of electrical power is to be provided which is to include at least two generating sets, one of which may be driven by the main engine. The Society may accept other arrangements having equivalent electrical capability.
- (b) The power of these sets is to be such as to ensure the functioning of the services referred to in 4.2.1(a)(i), excluding the power required in fishing activities, processing and preservation of the catch, in the event of any one of the generating sets being stopped. However, in ships of less than 45 m, in the event of any one of the generating sets being stopped, it is only necessary to ensure the functioning of the services essential for the propulsion and safety of the ship.
- (c) The arrangement of the ship's main source of electrical power is to be such that the services referred to in 4.2.1(a)(i) can be maintained regardless of the number of revolutions and direction of the main propelling engines or shafting.
- (d) Where transformers constitute an essential part of the supply system required by this item, the system is to be so arranged as to ensure continuity of the supply.
- (e) The arrangement of the main electric lighting system is to be such that a fire or other casualty in spaces containing the main source of electrical power, including transformers, if any, will not render the emergency lighting system inoperative.
- (f) The arrangement of the emergency electric lighting system is to be such that a fire or other casualty in spaces containing the emergency source of electrical power, including transformers, if any, will not render the main lighting system inoperative.
- (g) Navigation lights, if solely electrical, are to be supplied through their own separate switchboard and adequate means for the monitoring of such lights are to be provided.
- (h) For fishing vessels propelled by electrical power and having two or more constant voltage propulsion generating sets which constitute the source of electrical energy for the ship's auxiliary services, see Chapter 13 of Part VII of the Rules for Steel Ships.
- (i) Load shedding or other equivalent arrangements should be provided to protect the generators required in the present Article against sustained overload.
The load shedding should be automatic.
The non-essential services, services for habitability and, if necessary, the secondary essential services may be shed to make sure that the connected generator set(s) is/are not overloaded.
- (j) Where paralleling operation of the generators is needed, necessary instruments for this operation are to be provided.

(k) Instruments

- (1) The requirements of instrument in 5.7 of Part VII of the Rules for Steel Ships are applicable.
 - (2) Measuring instruments connected to the network and indicator lamps are to be protected by a fuse. Where a measuring instrument and an indicator lamp correspond to the same indication, each one is to be provided with a fuse.
 - (3) Requirements given in 5.1.8 of Part VII and 2.1.11(e) of Part VII of the Rules for Steel Ships are applicable to all fishing vessels.
 - (4) For each DC power source (e.g. converters, rectifiers and batteries), one voltmeter and one ammeter are to be provided, except for DC power sources for starting devices (e.g. starting motor for emergency generator). This requirement applies to all fishing vessels.
- (l) The main switchboards are to be placed far away from flammable gas, vapour accumulation, acid gas or other liquid. Their location is to be such that there is no pipe carrying liquids above, beside or near them. When this cannot be avoided, pipes are to be built joint less or provided with protections.

4.2.4 Emergency source of electrical power

- (a) A self-contained emergency source of electrical power located, to the satisfaction of the Society, outside machinery spaces is to be provided and so arranged as to ensure its functioning in the event of fire or other causes of failure of the main electrical installations.
- (b) The emergency source of electrical power is to be capable, having regard to starting currents and the transitory nature of certain loads, of serving simultaneously for a period of at least 3 hours:
 - (i) the VHF radio installation and, if applicable:
 - (1) the MF radio installation
 - (2) the ship earth station and
 - (3) the MF/HF radio installation
 - (ii) internal communication equipment, fire detection systems and signals which may be required in an emergency
 - (iii) the navigation lights if solely electrical and the emergency lights:
 - (1) of launching stations and overside of the ship
 - (2) in all alleyways, stairways and exits
 - (3) in spaces containing machinery or the emergency source of power
 - (4) in control stations, and
 - (5) in fishing handling and fish processing spaces, and
 - (iv) the operation of the emergency fire pump, if any.
- (c) The emergency source of electrical power may be either a generator or an accumulator battery.
- (d) Where the emergency source of electrical power is a generator, it is to be provided both with an independent fuel supply and with efficient starting arrangements to the satisfaction of the Society. Unless a second independent means of starting the emergency generator is provided, the single source of stored energy is to be protected to preclude its complete depletion by the automatic starting system.

- (e) Where the emergency source of electrical power is an accumulator battery, it is to be capable of carrying the emergency load without recharging whilst maintaining the voltage of the battery throughout the discharge period within $\pm 12\%$ of its nominal voltage. In the event of failure of the main power supply, this accumulator battery is to be automatically connected to the emergency switchboard and is to immediately supply at least those services specified in 4.2.4(b)(ii) and (iii). The emergency switchboard is to be provided with an auxiliary switch allowing the battery to be connected manually, in case of failure of the automatic connection system.
- (f) When the length of ship is less than 24 m, the start of the main engine of the ship is carried out by electrical starter and where the emergency source of power is a storage battery, the emergency source of power can be considered as the second required starting power source for the main engine. Then:
- (i) The starting system cables are to be designed to permit the necessary commutation with a changeover switch and fixed connections.
 - (ii) The available power of the emergency battery is to be adequate to supply the emergency services during the time specified in above paragraphs, and, in principle, have the capacity of 6 consecutive starts of the main engine.
- (g) The emergency switchboard is to be installed as near as is practicable to the emergency source of power and is to be located in accordance with 4.2.4(a). Where the emergency source of power is a generator, the emergency switchboard is to be located in the same place unless the operation of the emergency switchboard would thereby be impaired.
- (h) An accumulator battery, other than batteries fitted for the radio transmitter and receiver in ships of less than 45 m in length, is to be installed in a well ventilated space which is not to be the space containing the emergency switchboard. An indicator is to be mounted in a suitable place on the main switchboard or in the machinery control room to indicate when the battery constituting the emergency source of power is being discharged.
- (i) The emergency switchboard is to be supplied in normal operation from the main switchboard by an interconnector feeder which is to be protected at the main switchboard against overload and short-circuit and which is to be disconnected automatically at the emergency switchboard upon failure of the main source of electrical power.
- Where the system is arranged for feedback operation, the interconnector feeder is also to be protected at the emergency switchboard at least against short-circuit.
- For ships whose length is equal to or greater than 45 m, the arrangement at the emergency switchboard is to be such that in the event of failure of the main power supply an automatic connection of the emergency supply will be provided
- (j) The emergency generator and its prime mover and any emergency accumulator battery are to be so arranged as to ensure that they will function at full rated power when the ship is upright and when rolling up to an angle of 22.5° either way and simultaneously pitching 10° by bow or stern, or in any combination of angles within those limits.
- (k) The emergency source of electrical power and automation starting equipment is to be so constructed and arranged as to enable adequate testing to be carried out by the crew while the ship is in operating condition.
- (l) When the length is less than 24 m, unless otherwise specified by the Administration, the Society may exempt Owners from the installation of the emergency source of electrical power.
- (m) Where emergency generator is used in port, the requirements stated in 11.6 of Part VII of the Rules for Steel Ships are applicable.

4.2.5 Precaution against shock, fire and other hazards of electrical origin

- (a) Exposed permanently fixed metal parts of electrical machines or equipment which are not intended to be live but which are liable under fault conditions to become live are to be earthed (grounded) unless:
 - (i) they are supplied at a voltage not exceeding 50 V direct current or 50 V, root mean square between conductors; autotransformers are not to be used for the purpose of achieving this alternative current voltage, or
 - (ii) they are supplied at a voltage not exceeding 250 V by safety isolating transformers supplying one consuming device only, or
 - (iii) they are constructed in accordance with the principle of double insulation.
- (b) Electrical apparatus is to be so constructed and installed that it will not cause injury when handled or touched in the normal manner.
- (c) Main and emergency switchboards are to be so arranged as to give easy access as may be needed to apparatus and equipment, without danger to attendants. The sides, backs and, where necessary, the fronts of switchboards are to be suitably guarded. Exposed live parts having voltages to earth exceeding a voltage to be specified by the Society are not to be installed on the front of the switchboards. There are to be non-conducting mats or gratings at the front and rear, where necessary.
- (d) When a distribution system, whether primary or secondary, for power, heating or lighting, with no connection to earth is used, a device capable of monitoring the insulation level to earth is to be provided.
- (e) When a distribution system is in accordance with 4.2.5(d) and a voltage exceeding 50 V direct current or 50 V, root mean square, between conductors, is used, a device capable of continuously monitoring the insulation level to earth and of giving an audible or visual indication of abnormally low insulation values is to be provided.
- (f) Distribution systems which are supplied at a voltage not exceeding 250 V direct current or 250 V, root mean square, between conductors, and which are limited in extent, may comply with 4.2.5(d), subject to the satisfaction of the Society.
- (g) Except as permitted by the Society in exceptional circumstances, all metal sheaths and armour of cables are to be electrically continuous and to be earthed.
- (h) All electrical cables are to be at least of a flame-retardant type and are to be so installed as not to impair their original flame-retarding properties. The Society may permit the use of special types of cables where necessary for specific applications, such as radio frequency cables, which do not comply with the foregoing.
- (i) Cables and wiring serving essential or emergency power, lighting, internal communications or signals are as far as practicable to be routed clear of galleys, machinery spaces of category A and other high fire risk areas and laundries, fish handling and fish processing spaces and other spaces where there is a high moisture content. Cables connecting fire pumps to the emergency switchboard are to be of a fire-resistant type where they pass through high fire risk areas. Where practicable, all such cables are to be run in such a manner as to preclude their being rendered unserviceable by heating of the bulkheads which may be caused by a fire in an adjacent space.

- (j) Where cables which are installed in spaces where the risk of fire or explosion exists in the event of an electrical fault, special precautions against such risk are to be taken to the satisfaction of the Society. When fitted in places where flammable gases or vapours may accumulate, or in rooms intended to mainly contain accumulators, paint or similar material, the equipment is to be of a safety type approved by the Society.
- (k) Wiring is to be supported in such a manner as to avoid chafing or other damage.
- (l) Terminations and joints in all conductors are to be made such that they retain the original electrical, mechanical, flame-retardant and, where necessary, fire-resisting properties of the cable.
- (m) Cables installed in refrigerated compartments are to be suitable for low temperatures and high humidity.
- (n) Circuits are to be protected against short-circuit. Circuits are also to be protected against overload, unless otherwise specified in the Guidelines or the Rules for Steel Ships or where the Society may exceptionally otherwise permit.
- (o) The rating or appropriate setting of the overload protective device for each circuit is to be permanently indicated at the location of the protective device.
- (p) Lighting fittings are to be so arranged as to prevent temperature rises which could damage the wiring and to prevent surrounding material from becoming excessively hot.
- (q) Lighting or power circuits terminating in a space where the risk of fire or explosion exists are to be provided with isolating switches outside the space.
- (r) The housing of accumulator batteries is to be constructed and ventilated to the satisfaction of the Society.
- (s) Electrical or other equipment which may constitute a source of ignition of flammable vapours is not permitted in these compartments except as provided for in 4.2.5(u).
- (t) An accumulator battery is not to be located in accommodation spaces unless installed in a hermetically sealed container.
- (u) In spaces where flammable mixtures are liable to collect and in any compartments assigned principally to the containment of an accumulator battery, no electrical equipment is to be installed unless the Society is satisfied that it is:
 - (i) essential for operational purposes
 - (ii) of a type which will not ignite the mixture concerned
 - (iii) appropriate for the space concerned, and
 - (iv) appropriately certified for safe usage in the dusts, vapours or gases likely to be encountered.
- (v) Where shore supply is provided, requirements stated in 2.1.11 of Part VII of the Rules for Steel Ships are applicable. The socket-outlets used for the supply of the ship from the shore network and when the voltage exceeds 50 V, are to be provided with a built-in earth connection provided to be connected to the earth.
- (w) On board of ship with non-metallic hull, bonding is to be provided between the frame of generators, the bed plate of the pumps, the bed plate of the motors and the earth plate, if fitted. All the elements of the fuel installation are to be electrically bonded and connected to the above bonding.

- (x) If the protection of cables against overload current is made by fuses, their rating is to be selected according to the maximum permissible current in the cable.
- (y) Particular attention is to be paid to the fixing of equipment made of cast brass or other copper alloys on aluminium decks or bulkheads.
- (z) Heaters
Electric heaters are to be permanently installed.
They are to be constructed and installed in such a way that clothing or other combustible objects cannot be left there or be hung above these heaters.

4.2.6 Engineers' alarm

- (a) In ships of 75 m in length and over, an engineers' alarm is to be provided to be operated from the engine control room or at the manoeuvring platform as appropriate, and is to be clearly audible in the engineers' accommodation.

4.2.7 Fire detection and fire alarm

- (a) The fire detection and fire alarm system are to be supplied from the main source and an emergency source.

4.2.8 Alarm – Communication

- (a) For the crew muster, an alarm system operated from the bridge is to be provided. This system may be part of the general alarm system.
- (b) Ships of 12 m or more in length are to be equipped with a system enabling the general broadcast of alarm and messages in case of damage or ship escape.
- (c) The bridge operating compartment is to be fitted with the internal communication and control means as quoted hereunder:
 - (i) An engine room telegraph with repeater, or equivalent system, is to be provided and duplicated by another independent system, enabling the communication with the engine control position. If the size and arrangement of the ship make useless the equipment mentioned above, only a dual calling system such as telephone, megaphone or bell may be fitted.
 - (ii) If the propelling machinery is remote-controlled from the bridge-operating compartment, at least one order telegraph, reversible or with repeater, is to be fitted at the local direct engine control position.
 - (iii) Furthermore, unless the size and arrangement of the ship make useless this equipment, the bridge operating compartment is to be connected by means of a reversible voice communication system to the local control of steering gear, propelling machinery and the service accommodation.

4.2.9 Final sub-circuits

- (a) Every final sub-circuit connected to a distribution panel is to be protected, unless otherwise specified, by a fuse or a maximum current circuit breaker on each insulated pole. These circuits can be controlled by single pole switches in dry spaces of the accommodation. A separate final sub-circuit is to be provided for every apparatus assuming an essential service and for each motor rated 1 kW or more.

4.2.10 Electric cables

- (a) General requirements given in Chapter 8 of Part VII of Rules for Steel Ships are applicable for all fishing vessels.
- (b) Choice of runs
 - (i) Cable runs are to be as straight and accessible as possible.
 - (ii) Cable runs are to be fitted away from source of water. Cables exposed to the risk of mechanical damage, if not armoured or enclosed in steel conduits, are to be protected by a casing.
 - (iii) The cable runs are to be so designed that the internal radius of bend does not exceed at any point the permissible value for the cable concerned. In the absence of values specified by the manufacturer, the following values are to be adopted as minimum for the internal radius of bend:
 - (1) $4d$ for rubber-like insulated cables without metallic covering ($6d$ if $d > 25$ mm)
 - (2) $6d$ for rubber-like insulated cables with metallic covering or for silicone asbestos for PVC insulated cables.
- (c) Cable fixing
 - (i) Cables are to be bunched as regularly as possible.
 - (ii) Cables are to be so arranged as to avoid any friction; if needed, fastening parts are to be used. The distance between fastening parts is to be defined according to the cable nature and the special installation provisions. The distance between two fastening parts is generally not to exceed 0.50 m.

4.2.11 Switchboard

- (a) Installation

When the voltage exceeds 50 V, AC or DC, an insulated mat, grating or impregnated wood surface is to be provided in front of switchboards and also at the rear if access to the rear is provided. The insulated mat, grating or surface is to be oil-resistant and non-slippery.
- (b) Design - Construction

Generally, switchboards or enclosures containing switchboards are to be constructed of durable, flame retardant and non-hygroscopic materials. In addition, mechanical features of the materials are to be suitable for the service conditions.

Live parts normally submitted to a voltage exceeding 50 V are not to be installed without protection on the front of switchboards.

The switchboard frame or enclosures containing switchboards are to be earthed.

Air clearances between live parts are to be suitable for the rated voltage or protected by means of insulating and fireproof shields. Every switchboard part, including the connections, is to be easily accessible.

4.2.12 Rotating electrical machines

- (a) Location – Installation

Machines and their gears are to be located in spaces suitably ventilated where flammable dusts, vapours or gases cannot accumulate. Where this condition, in the case of motors, cannot be fulfilled, the Society is to be advised accordingly and a special consideration will be given, after examination, of the proposed arrangements.
- (b) Earthing

Bed plates and framework of machines or generating sets are to be efficiently earthed; no insulating material is to be placed between the prime movers and the alternators and generally between the prime movers and the driven machines, unless there is one efficient earthing of each part.

(c) Generators speed control

Prime movers for driving generators are to be fitted with a speed regulator in such a way that at all loads between no load and rated power the permanent speed variations cannot exceed 5% of the rated speed. For Diesel generating sets, when the rated power is suddenly thrown off, the transient speed variations are not to exceed 10%.

The generators driven by the propulsion engine, by a geared shaft or by an auxiliary set intended for another purpose, are to be designed with consideration that the variation of speed may occur in service.

(d) Particular provisions for the motor control device – Starters

(i) DC and AC motors of more than 0.5 kW are to be fitted with a under-voltage protection and a protection against overload. Under-voltage protection may not be provided for steering gear motor or any other motor the continuous running of, which is essential.

(ii) When the starter, the selector switch or all other equipment used to cut off completely the supply of the motor is at a distance from it, it is recommended that one of the following measures be applied:

- (1) locking of the disconnecting switch of the circuit in open position, or removable fuses.
- (2) installation near to the motor of a second disconnecting switch.

4.2.13 Batteries

(a) As general, Chapter 6 of Part VII of Rules for Steel Ships is applicable.

(b) Where the length is less than 24 m, the following is also applicable:

(i) Batteries which can be charged by a power exceeding 2 kW (calculated from the maximum charging current of the charging apparatus and from the nominal voltage of the battery) are to be installed in a ventilated suitable space or in a locker protected from dangerous gas accumulation.

(c) For all fishing vessels:

(i) All spaces especially reserved for batteries, including lockers or chests, boxes, shelves are to be protected against the deleterious effects of the electrolyte. The batteries are to be so manufactured and installed that no electrolyte discharge may occur under 22.5° inclination.

(ii) Deck boxes are to be provided with exhaust ducts on top and air inlets at lower part. The assembly is to be suitably weatherproof. For battery of low capacity, only openings on the top of the battery box are required.

4.3 Lightning Protection

4.3.1 Application

(a) A lightning protection system is to be fitted for:

- (i) ships with wooden hull or of composite construction with wooden masts
- (ii) ships with wooden hull or of composite construction with steel masts
- (iii) ships with steel hull with wooden masts.

- (b) Lightning conductors are to be fitted to all wooden masts or topmasts. In ships constructed of non-conductive materials, the lightning conductors are to be connected to a copper plate fixed to the ship's hull well below the waterline.
- (c) Lightning fittings exposed to risks of mechanical damage are to be suitably protected or strongly built.

4.4 Explosion protection

The construction and type testing of the safe type electrical equipment is to be in accordance with the IEC 60079 Series Electrical Apparatus for Explosive Gas Atmospheres. The explosion groups and temperature classes of ammonia plant rooms are at least to meet the temperature class T1 and gas group IIA.

CHAPTER 5 MISCELLANEOUS

5.1 Fishing Machinery

5.1.1 General provisions

(a) Application

Where requested by the owner, the provisions of this Chapter apply to the design, manufacturing, installation and tests of fishing machinery (e.g., net winches, steel winches and fish pumps). In addition to this Chapter, the hydraulic transmission and mechanical systems should be in accordance with requirements of relevant sections in Part IV & Part VI of the Rules for Steel Ships, and the electrical transmission and control systems should be in accordance with requirements of Part VII & Part VIII of the Rules for Steel Ships.

(b) Design and arrangements

- (i) Fishing machinery is to be so designed and arranged to facilitate observation, operation and maintenance.
- (ii) Consoles of fishing machinery are to be so arranged that operators can clearly see net hauling and release as well as liaison signals.
- (iii) Where consoles are apart from fishing machinery, operating gears are to be still fitted nearby, and safe interlocking devices are to be fitted between them. Necessary instruments are to be fitted to the consoles for display.
- (iv) Bases of fishing machinery are to be of sufficient strength and rigidity and firmly connected with the hull structure.
- (v) Where main engine shafts drive the hydraulic oil pumps of winches, clutches and flexible couplings are to be fitted. The clutches are to have a margin coefficient no less than 1.5.

(c) Protection and overload protection

- (i) Means of protection are to be provided for moving parts of fishing machinery where appropriate to avoid accidental injury to people.
- (ii) Where the height of working platform exceeds 1.5 m, railings with the height of no less than 1 m are to be provided.
- (iii) Fishing machinery is to be provided with load protection devices such as slip clutches, overflow valves and relief valves, to limit the maximum torque of driving. Such protection devices are to be in a construction and position facilitating inspection and maintenance.

(d) Reversal and speed variation

Fishing machinery is generally to have performance of reversal and speed variation.

5.1.2 Winch

(a) Definitions

For the purpose of this paragraph, winch means power machinery for hauling and releasing net, e.g., net winches and steel winches.

(b) Materials

- (i) Vital components in the power transmission system are to be made of steel, cast iron or spheroidal or nodular graphite cast iron in compliance with Part XI of the Rules for Steel Ships.

- (ii) Hose components are to be complied with requirements of 2.9 of Part VI of the Rules for Steel Ships.
- (c) Design
 - (i) Winches are to generally be independent of other deck machinery. Pipes of hydraulic systems may be connected to other hydraulic systems other than steering gears, provided that no mutual interference is resulted in.
 - (ii) For overflow valves of hydraulic winches, the regulated pressure is not to exceed the maximum working pressure of hydraulic system.
 - (iii) The rated output of power units is to meet the demand of rated load and corresponding winch speed. Generally, the maximum torque of power units is not to be less than 1.5 times rated torque.
 - (iv) Load transmission components are to be designed based on the maximum torque aforesaid.
 - (v) Consideration is to be given to the load to be withstood by reel brake during the reel shaft calculation.
 - (vi) Hydraulic systems of hydraulic winches are to be fitted with strict hydraulic purification devices, and magnetic devices are to be fitted for filters at the inlet of oil pump.
 - (vii) Hydraulic motors are to have self-locking function.
 - (viii) Facilities are to be provided to prevent fishing tools from entering the destination at excessively high speed, but such facilities are not to disconnect the power unit.
 - (ix) The calculated stress applied on components is to be less than 40% of yield point of used material and to be no more than 23% of the breaking strength of the material.
- (d) Controls
 - (i) Winches with double reels are to be provided with independent controls.
 - (ii) The hand wheel or levers are to be operated clockwise or forward when the winch is lifted and anti-clockwise or backward when the winch is released. A locking device preventing automatic shift is to be fitted to the hand wheel or lever.
 - (iii) Where remote control is provided, reels are to be operated simultaneously to operate in synchronization, and an interlocking device is to be fitted between the remote control and control at the engine side.
- (e) Clutches and brakes
 - (i) Clutches easy to operate are to be fitted between winches and driving shafts.
 - (ii) Reel brakes of winches are to be capable of fully braking when winches are released or maximum load is lifted, and the margin coefficient is to be no less than 1.5.
 - (iii) Brakes of winches are to prevent steel cables from being released automatically in the event of a fault. Automatic emergency stop devices are to be fitted when necessary.
 - (iv) For mechanically driven winches, interlocking devices may be fitted between brakes and clutches when possible.
 - (v) Where automatic brakes are fitted, manual release devices are to be provided.
- (f) Reels
 - (i) The reel diameter is not to be less than 14 times diameter of reeled steel cable.
 - (ii) The diameter of marginal plates at both ends of reel is to be at least greater than the diameter of the outmost-layer circle plus two times diameter of steel cables. It may be increased where appropriate in case of no cable arrangement device.
 - (iii) Means are to be provided to prevent all steel cables from being completely released.
- (g) Cables arrangement devices

CHAPTER 5 MISCELLANEOUS

5.1 Fishing Machinery

- (i) Reels of winches are to be fitted with automatic cable arrangement devices to ensure uniform cables reeling. Cable arrangement devices are to be fitted with manual regulating mechanisms, and manual reels may be dispensed.
 - (ii) Clutches are to be fitted between cable arrangement devices and transmission gears.
- (h) Friction bosses
- (i) All power-driven friction bosses for pulling ropes are to be of sufficient strength and rigidity.
 - (ii) The working surface of friction bosses is to be smooth and be of sufficient rigidity to prevent steel cables from being ground to grooves.
 - (iii) The working surface of friction bosses is to be in a construction to prevent steel cables from rolling out when pulled.
 - (iv) Safety facilities are to be fitted at the direction where cables enter friction bosses to prevent injuring operators due to cables overlaying.
 - (v) Friction bosses are to be fitted with some cooling facilities.

5.1.3 Delivery mechanisms

(a) General requirements

Where a conveyor system is composed of multiple conveyors, emergency switches for stopping all conveyors are to be fitted at an interval of no more than 10 m. when the length of conveyor system is greater than 15 m, audible and visual alarm devices for startup are to be fitted.

5.1.4 Tests

(a) General requirements

- (i) Fishing machinery is to be subject to bench test at the manufacturer's works. The heavy-duty test is to be carried out for 3 min at no less than 125% of nominal load and rated speed.
- (ii) After the installation of the fishing machinery, the mooring and navigation tests are to be carried out in accordance with the testing schedule agreed by the Society. The first or first pair of fishing vessels of each type constructed by each shipyard normally are to be subject to fishing trials. The safety-related contents of the fishing trial schedule are to be approved by the Society.