

4 ALBERT EMBANKMENT  
LONDON SE1 7SR  
Telephone: +44 (0)20 7735 7611 Fax: +44 (0)20 7587 3210

MSC.1/Circ.1628  
14 December 2020

**REVISED STANDARDIZED LIFE-SAVING APPLIANCE EVALUATION AND TEST  
REPORT FORMS (PERSONAL LIFE-SAVING APPLIANCES)**

1 The Maritime Safety Committee, at its 102nd session (4 to 11 November 2020), approved the *Revised standardized life-saving appliance evaluation and test report forms*.

2 The original forms, as set forth in the *Standardized life-saving appliance evaluation and test report forms* (MSC/Circ.980) and its addenda, were developed on the basis of the requirements of the International Life-Saving Appliance (LSA) Code and the *Revised recommendation on testing of life-saving appliances* (resolution MSC.81(70)) by the Maritime Safety Committee, at its seventy-third session in 2001, with a view to providing guidance on how to conduct tests, record test data and verify tests. The Committee has since adopted seven amendments to the LSA Code and eight amendments to resolution MSC.81(70). These amendments have been incorporated in the original forms which, due to their volume, are now presented in six separate circulars, i.e. MSC.1/Circ.1628, MSC.1/Circ.1629, MSC.1/Circ.1630, MSC.1/Circ.1631, MSC.1/Circ.1632 and MSC.1/Circ.1633, pertaining to the equipment addressed in chapters II to VII of the LSA Code, respectively. The forms annexed to this circular apply to the equipment addressed in chapter II of the LSA Code, i.e. personal life-saving appliances (lifebuoys and associated equipment; lifejackets and associated equipment; immersion suits and associated equipment; anti-exposure suits; and thermal protective aids).

3 The use of the revised forms will continue to be of benefit to Administrations and other parties, such as manufacturers, test facilities, owners and surveyors, and will be a major help in mutually accepting the type approval of appliances approved by other Administrations.

4 Member Governments are invited to bring the annexed revised forms to the attention of all parties concerned with approving, manufacturing and testing life-saving appliances and to encourage them to use the forms.

5 This circular supersedes MSC/Circ.980.

\*\*\*



## ANNEX

### REVISED STANDARDIZED LIFE-SAVING APPLIANCE EVALUATION AND TEST REPORT FORMS (PERSONAL LIFE-SAVING APPLIANCES)

#### INTRODUCTION

##### Reference

These standardized life-saving appliance evaluation and test report forms have been revised on the basis of the requirements of the International Life-Saving Appliance (LSA) Code, as amended through resolution MSC.425(98), *the Revised recommendation on testing of life-saving appliances* (resolution MSC.81(70)), as amended through resolution MSC.427(98), and the *Recommendation on means of rescue on ro-ro passenger ships* (MSC/Circ.810).

##### Status

In general, the tests described in the Revised recommendation (resolution MSC.81(70)) constitute the test procedures and the LSA Code sets the acceptance criteria. The evaluation and test report forms are guidelines on how to conduct tests, record test data and verify tests. These forms are not intended to change the standards given in the LSA Code and resolution MSC.81(70), as amended. In the case of inconsistency between the forms and the LSA Code or the Revised recommendation, the text of the Code/resolution should prevail over that of the forms.

##### Layout

Each Administration may use electronically distributed evaluation and test report forms as the basis for customising the layout to reflect the profile of the approving body, without changing the original contents.

##### Internal references

The evaluation and test report forms should be stand-alone documents. Therefore, all internal references in the original text from the LSA Code or resolution MSC.81(70) have been replaced by either the full-length text or a reference to other relevant evaluation and test report forms. However, in some of the forms, external references are kept for updating purposes.

##### Documentation of tests

For approval purposes, all detailed records of test data are to be enclosed with the report forms.

##### Verification of tests

Each test is to be verified passed or failed by an Administration representative's initials (e.g. recognized organization or surveyor) and date of testing. Each page is to be verified on completion by the Administration representative's signature and its date of completion.

### **Reporting of type approval**

To facilitate unified reporting procedures, the completed evaluation and test report forms are to be seen as a documented verification of required type approval tests for each type of equipment. When documentation of type approval is required by a third party, the verified evaluation and test report forms should constitute the complete documentation of the type approval together with the relevant approval certificates.

**REVISED STANDARDIZED LIFE-SAVING APPLIANCE  
EVALUATION AND TEST REPORT FORMS  
(PERSONAL LIFE-SAVING APPLIANCES)**

**TABLE OF CONTENTS**

LSA Code chapter II (Personal life-saving appliances) – Equipment:

- 2.1 Lifebuoys and associated equipment
  - 2.1.1 Lifebuoys
  - 2.1.2 Lifebuoy self-igniting lights
  - 2.1.3 Lifebuoy self-activating smoke signals
  
- 2.2 Lifejackets and associated equipment
  - 2.2.1 Inherently buoyant lifejackets
  - 2.2.2 Inflatable lifejackets
  - 2.2.3 Lifejacket/immersion suit lights
  - 2.2.4 Reference Test Device (RTD)
  
- 2.3 Immersion suits and associated equipment
  - 2.3.1 Immersion suits (non-insulated)
  - 2.3.2 Immersion suits (insulated)
  
- 2.4 Anti-exposure suits
  
- 2.5 Thermal protective aids

## **2.1 LIFEBUOYS AND ASSOCIATED EQUIPMENT**

### **2.1.1 LIFEBUOYS**

#### **EVALUATION AND TEST REPORT**

- 2.1.1.1 Submitted drawings, reports and documents
- 2.1.1.2 Quality assurance
- 2.1.1.3 Visual inspection
- 2.1.1.4 Temperature cycling test
- 2.1.1.5 Drop test
- 2.1.1.6 Test for oil resistance
- 2.1.1.7 Fire test
- 2.1.1.8 Flotation test
- 2.1.1.9 Strength test
- 2.1.1.10 Test for operation with a light and smoke signal

**2.1.1 LIFEBOUYS  
EVALUATION AND TEST REPORT**

<b>Manufacturer</b>	
<b>Type</b>	
<b>Date</b>	
<b>Place</b>	
<b>Name Surveyor printed</b>	
<b>Signature</b>	
<b>Approving Organization</b>	

<b>Lifebuoys</b>	Manufacturer: _____ Model: _____ Lot/Serial Number: _____	Date: _____ Time: _____ Surveyor: _____ Organization: _____
------------------	---	---

<b>2.1.1.1 Submitted drawings, reports and documents</b>			
<b>Submitted drawings and documents</b>			<b>Status</b>
<b>Drawing No.</b>	<b>Revision No. &amp; date</b>	<b>Title of drawing</b>	
<b>Submitted reports and documents</b>			<b>Status</b>
<b>Report/Document No.</b>	<b>Revision No. &amp; date</b>	<b>Title of report / document</b>	
		Maintenance Manual -	
		Operations Manual -	



<b>Lifebuoys</b>	Manufacturer: _____ Model: _____ Lot/Serial Number: _____	Date: _____ Time: _____ Surveyor: _____ Organization: _____	
<b>2.1.1.2 Quality assurance</b>		<b>Regulations: MSC.81(70) 2/1.1, 1.2</b>	
<p>Except where all appliances of a particular type are required by chapter III of the International Convention for the Safety of Life at Sea, 1974, as amended, or the International Life-Saving Appliance (LSA) Code, to be inspected, representatives of the Administration should make random inspection of manufacturers to ensure that the quality of life-saving appliances and the materials used comply with the specification of the approved prototype life-saving appliance.</p> <p>Manufacturers should be required to institute a quality control procedure to ensure that life-saving appliances are produced to the same standard as the prototype life-saving appliance approved by the Administration and to keep records of any production tests carried out in accordance with the Administration's instructions.</p>		Quality Assurance Standard Used: Quality Assurance Procedure: Quality Assurance Manual:	Passed/ Failed Passed/ Failed Passed/ Failed

<b>Lifebuoys</b>	Manufacturer: _____ Model: _____ Lot/Serial Number: _____	Date: _____ Time: _____ Surveyor: _____ Organization: _____
<b>2.1.1.3 Visual inspection</b>		<b>Regulations: LSA Code 1.2.2</b>
<b>Test Procedure</b>	<b>Acceptance Criteria</b>	<b>Significant Test Data</b>
Visually inspect the lifebuoy. Conduct measurements and verify characteristics as required.	Be of international or vivid reddish orange, or a comparably highly visible colour on all parts where this will assist detection at sea.  Fitted with approved retro-reflective material in compliance with resolution A.658(16).  Clearly marked with approval information from the organization that approved it and any operational restrictions.	Colour(s): Passed _____ Failed _____  Quantity:                      Spacing: Passed _____ Failed _____  Any operational restrictions? Passed _____ Failed _____  Comments/Observations

<b>Lifebuoys</b>	Manufacturer: _____	Date: _____ Time: _____
	Model: _____ Lot/Serial Number: _____	Surveyor: _____ Organization: _____
<b>2.1.1.3 Visual inspection (continued)</b>		<b>Regulations: LSA Code 2.1.1</b>
<b>Test Procedure</b>	<b>Acceptance Criteria</b>	<b>Significant Test Data</b>
<p>It should be established by measurement, weighing and inspection that:</p> <p>Measure the inner and outer diameter.</p> <p>Weigh the lifebuoy.</p> <p>If it is intended to operate the quick-release arrangement provided for a self-activated smoke signal and self-igniting light, conduct the test in 2.1.1.10.</p> <p>Measure the lifebuoy grab-line diameter and length and assess how it is secured.</p>	<p>Be constructed of inherently buoyant material; it should not depend upon rushes, cork shavings or granulated cork, any other loose granulated material or any air compartment which depends on inflation for buoyancy.</p> <p>Should have an outer diameter of not more than 800 mm and an inner diameter of not less than 400 mm</p> <p>Not designed for quick release: Should have a mass of not less than 2.5 kg</p> <p>If it is intended to operate the quick-release arrangement provided for a self-activated smoke signal and self-igniting light, the lifebuoy has a mass of not less than 4 kg.</p> <p>Be fitted with a grab-line not less than 9.5 mm in diameter and not less than four times the outside diameter of the body of the buoy in length.</p> <p>The grab-line should be secured at four equidistant points around the circumference of the buoy to form four equal loops.</p>	<p>Construction materials:</p> <p>Outer diameter: _____ mm Inner diameter: _____ mm</p> <p>Mass: _____ kg</p> <p>Type / description of quick release arrangement:</p> <p>Does the lifebuoy have sufficient mass to activate the quick-release arrangement for a self-activated smoke signal and self-igniting light?    Passed/ Failed</p> <p>Weight: _____ kg</p> <p>Grab-line diameter: _____ mm</p> <p>Grab-line length: _____ mm</p> <p>Buoy outer diameter times four: _____ mm Grab-line four times the outer diameter of body?    Passed/ Failed</p> <p>Grab-line secured in four equal loops?    Passed/ Failed</p> <p>Comments/Observations</p>

<b>Lifebuoy</b>	Manufacturer: _____ Model: _____ Lot/Serial Number: _____	Date: _____ Time: _____ Surveyor: _____ Organization: _____
<b>2.1.1.4 Temperature cycling test</b>		<b>Regulations: LSA Code 1.2.2; MSC.81(70) 1 / 1.2</b>
<b>Test Procedure</b>	<b>Acceptance Criteria</b>	<b>Significant Test Data</b>
<p>The following test should be carried out on two lifebuoy.</p> <p>Two lifebuoy should be alternately subjected to surrounding temperatures of -30°C and +65°C.</p> <p>These alternating cycles need not follow immediately after each other and the following procedure, repeated for a total of 10 cycles, is acceptable:</p> <p>An 8 h exposure at a minimum temperature of +65°C to be completed in one day</p> <p>The specimens removed from the warm chamber that same day and left exposed under ordinary room conditions at a temperature of 20°C ± 3°C until the next day</p> <p>An 8 h exposure at a maximum temperature of -30°C to be completed the next day</p> <p>The specimens removed from the cold chamber that same day and left exposed under ordinary room conditions at a temperature of 20°C ± 3°C until the next day.</p>	<p>Not be damaged in stowage throughout the air temperature range - 30°C to + 65°C</p> <p>The lifebuoy should show no sign of loss of rigidity under high temperatures and, after the tests, should show no sign of damage such as shrinking, cracking, swelling, dissolution or change of mechanical qualities.</p>	<p>Passed _____ Failed _____</p> <p>(See following page for test data)</p> <p>Intact after this test?</p> <p>Lifebuoy No. 1 Observations on rigidity under high temp</p> <p>Observations after testing for shrinking, cracking etc.</p> <p>Lifebuoy No. 2 Observations on rigidity under high temp</p> <p>Observations after testing for shrinking, cracking etc.</p> <p>Intact after these tests?</p> <p>lifebuoy No.1: Passed/ Failed</p> <p>lifebuoy No.2: Passed/ Failed</p> <p>Comments/Observations</p>

<b>Lifebuoys</b>	Manufacturer: _____		Date: _____ Time: _____	
	Model: _____		Surveyor: _____	
	Lot/Serial Number: _____		Organization: _____	
<b>2.1.1.4 Temperature cycling test – Test data</b>			<b>Regulations: LSA Code I/1.2.2; MSC.81(70) 1/1.2</b>	
	<b>HOT CYCLE</b>		<b>COLD CYCLE</b>	
<b>Cycle 1</b>	Date In: _____ Time In: _____ Temperature: _____ °C	Date Out: _____ Time Out: _____ Duration: _____ hours	Date In: _____ Time In: _____ Temperature: _____ °C	Date Out: _____ Time Out: _____ Duration: _____ hours
<b>Cycle 2</b>	Date In: _____ Time In: _____ Temperature: _____ °C	Date Out: _____ Time Out: _____ Duration: _____ hours	Date In: _____ Time In: _____ Temperature: _____ °C	Date Out: _____ Time Out: _____ Duration: _____ hours
<b>Cycle 3</b>	Date In: _____ Time In: _____ Temperature: _____ °C	Date Out: _____ Time Out: _____ Duration: _____ hours	Date In: _____ Time In: _____ Temperature: _____ °C	Date Out: _____ Time Out: _____ Duration: _____ hours
<b>Cycle 4</b>	Date In: _____ Time In: _____ Temperature: _____ °C	Date Out: _____ Time Out: _____ Duration: _____ hours	Date In: _____ Time In: _____ Temperature: _____ °C	Date Out: _____ Time Out: _____ Duration: _____ hours
<b>Cycle 5</b>	Date In: _____ Time In: _____ Temperature: _____ °C	Date Out: _____ Time Out: _____ Duration: _____ hours	Date In: _____ Time In: _____ Temperature: _____ °C	Date Out: _____ Time Out: _____ Duration: _____ hours
<b>Cycle 6</b>	Date In: _____ Time In : _____ Temperature : _____ °C	Date Out: _____ Time Out: _____ Duration : _____ hours	Date In: _____ Time In: _____ Temperature: _____ °C	Date Out: _____ Time Out: _____ Duration: _____ hours
<b>Cycle 7</b>	Date In: _____ Time In : _____ Temperature : _____ °C	Date Out: _____ Time Out: _____ Duration: _____ hours	Date In: _____ Time In: _____ Temperature: _____ °C	Date Out: _____ Time Out: _____ Duration: _____ hours
<b>Cycle 8</b>	Date In: _____ Time In: _____ Temperature: _____ °C	Date Out: _____ Time Out: _____ Duration: _____ hours	Date In: _____ Time In: _____ Temperature: _____ °C	Date Out: _____ Time Out: _____ Duration: _____ hours
<b>Cycle 9</b>	Date In: _____ Time In: _____ Temperature: _____ °C	Date Out: _____ Time Out: _____ Duration: _____ hours	Date In: _____ Time In: _____ Temperature: _____ °C	Date Out: _____ Time Out: _____ Duration: _____ hours
<b>Cycle 10</b>	Date In: _____ Time In: _____ Temperature: _____ °C	Date Out: _____ Time Out: _____ Duration: _____ hours	Date In: _____ Time In: _____ Temperature: _____ °C	Date Out: _____ Time Out: _____ Duration: _____ hours

<b>Lifebuoys</b>	Manufacturer: _____ Model: _____ Lot/Serial Number: _____	Date: _____ Time: _____ Surveyor: _____ Organization: _____
<b>2.1.1.5 Drop test</b>		<b>Regulations: LSA Code 2.1.1.6; MSC.81(70) 1 / 1.3</b>
Test Procedure	Acceptance Criteria	Significant Test Data
<p>Each lifebuoy should be suspended from its upper edge via a release device so that the lower edge of the lifebuoy is at the height at which it is intended to be stowed on ships in their lightest seagoing condition, or 30 m, whichever is the greater, and dropped into the water without suffering damage.</p> <p>In addition, one lifebuoy should be suspended from its upper edge via a release device so that the lower edge of the lifebuoy is at a height of 2 m, and dropped three times onto a concrete floor.</p>	<p>Be constructed to withstand a drop into the water from the height at which it is stowed above the waterline in the lightest seagoing condition or 30 m, whichever is the greater, without impairing either its operating capability or that of its attached components.</p> <p>The lifebuoy should withstand three drops from a height of 2m on to a concrete floor without suffering damage.</p>	<p>Number of lifebuoys: _____</p> <p>Lifebuoy no. 1          Drop height in water: _____m          Number of drops: _____m          Passed/ Failed</p> <p>Lifebuoy no. 2          Drop height in water: _____m          Number of drops: _____m          Passed/ Failed</p> <p>Condition lifebuoy no. 1: _____          Passed/ Failed</p> <p>Condition lifebuoy no. 2: _____          Passed/ Failed</p> <p>Lifebuoy selected for 2m drop height on concrete:          Drop 1: Passed/ Failed          Drop 2: Passed/ Failed          Drop 3: Passed/ Failed          Comments/Observations</p>

<b>Lifebuoys</b>	Manufacturer: _____	Date: _____ Time: _____
	Model: _____ Lot/Serial Number: _____	Surveyor: _____ Organization: _____
<b>2.1.1.6 Test for oil resistance</b>	<b>Regulations: LSA Code 1.2.2; MSC.81(70) 1 / 1.4</b>	
Test Procedure	Acceptance Criteria	Significant Test Data
One of the lifebuoys should be immersed horizontally for a period of 24 h under a 100 mm head of diesel oil at normal room temperature.	After this test the lifebuoy should show no sign of damage such as shrinking, cracking, swelling, dissolution or change of mechanical qualities.	Lifebuoy No. Diesel oil head: _____mm Duration: _____hours Signs of damage? Passed Failed Comments/Observations

<b>Lifebuoys</b>	Manufacturer: _____ Model: _____ Lot/Serial Number: _____	Date: _____ Time: _____ Surveyor: _____ Organization: _____
<b>2.1.1.7 Fire test</b>		<b>Regulations: LSA Code 2.1.1.5; MSC.81(70) 1/1.5</b>
Test Procedure	Acceptance Criteria	Significant Test Data
<p>The other lifebuoy should be subjected to a fire test. A test pan 30 cm x 35 cm x 6 cm should be placed in an essentially draught-free area. Water should be put in the bottom of the test pan to a depth of 1 cm followed by enough petrol to make a minimum total depth of 4 cm.</p> <p>The petrol should then be ignited and allowed to burn freely for 30 s.</p> <p>The lifebuoy should then be moved through flames in an upright, forward, free-hanging position, with the bottom of the lifebuoy 25 cm above the top edge of the test pan so that the duration of exposure to the flames is 2 s.</p>	<p>The lifebuoy should not sustain burning or continue melting after being removed from the flames.</p>	<p>Lifebuoy No.</p> <p>Dimensions test pan: ____ x ____ x ____ cm</p> <p>Water depth: _____ cm Depth</p> <p>incl. petrol: _____ cm</p> <p>Exposure time: _____ seconds</p> <p>Sustain burning or continue melting after being removed from the flame</p> <p>Passed/ Failed</p> <p>Comments/Observations</p>



<b>Lifebuoys</b>	Manufacturer: _____	Date: _____ Time: _____																		
	Model: _____ Lot/Serial Number: _____	Surveyor: _____ Organization: _____																		
<b>2.1.1.8 Flotation test</b>		<b>Regulations: LSA Code 2.1.1.3; MSC.81(70) 1/1.6</b>																		
<b>Test Procedure</b>	<b>Acceptance Criteria</b>	<b>Significant Test Data</b>																		
The two lifebuoys subjected to the above tests should be floated in fresh water with not less than 14.5 kg of iron suspended from each of them and should remain floating for a period of 24 h.	There should be no breaks, cracks or permanent deformation. The lifebuoys should float throughout the 24 h test period.	<table border="0"> <tr> <td></td> <td style="text-align: center;">Lifebuoy no. 1</td> <td style="text-align: center;">Lifebuoy no. 2</td> </tr> <tr> <td>Suspended mass:</td> <td style="text-align: center;">kg</td> <td style="text-align: center;">kg</td> </tr> <tr> <td>Float duration:</td> <td style="text-align: center;">min</td> <td style="text-align: center;">min</td> </tr> <tr> <td>Intact after this test?</td> <td colspan="2" style="text-align: center;">Passed/ Failed</td> </tr> <tr> <td>Float for entire test period?</td> <td colspan="2" style="text-align: center;">Passed/ Failed</td> </tr> <tr> <td colspan="3">Comments/Observations</td> </tr> </table>		Lifebuoy no. 1	Lifebuoy no. 2	Suspended mass:	kg	kg	Float duration:	min	min	Intact after this test?	Passed/ Failed		Float for entire test period?	Passed/ Failed		Comments/Observations		
	Lifebuoy no. 1	Lifebuoy no. 2																		
Suspended mass:	kg	kg																		
Float duration:	min	min																		
Intact after this test?	Passed/ Failed																			
Float for entire test period?	Passed/ Failed																			
Comments/Observations																				
<b>2.1.1.9 Strength test</b>		<b>Regulations: LSA Code 1.2.2; MSC.81(70) 1/1.7</b>																		
<b>Test Procedure</b>	<b>Acceptance Criteria</b>	<b>Significant Test Data</b>																		
A lifebuoy body should be suspended by a 50 mm wide strap. A similar strap should be passed around the opposite side of the body with a 90 kg mass suspended from it. After 30 min, the lifebuoy body should be examined.	There should be no breaks, cracks or permanent deformation.	<table border="0"> <tr> <td>Lifebuoy No.</td> <td></td> </tr> <tr> <td>Suspended mass:</td> <td>_____ kg</td> </tr> <tr> <td>Suspension duration:</td> <td>_____ min</td> </tr> <tr> <td>Passed/Failed</td> <td></td> </tr> <tr> <td colspan="2">Comments/Observations</td> </tr> </table>	Lifebuoy No.		Suspended mass:	_____ kg	Suspension duration:	_____ min	Passed/Failed		Comments/Observations									
Lifebuoy No.																				
Suspended mass:	_____ kg																			
Suspension duration:	_____ min																			
Passed/Failed																				
Comments/Observations																				

<b>Lifebuoys</b>	Manufacturer: _____	Date: _____ Time: _____
	Model: _____	Surveyor: _____
	Lot/Serial Number: _____	Organization: _____

<b>2.1.1.10 Test for operation with a light and smoke signal</b>		<b>Regulations: LSA Code 2.1.1.7; MSC.81(70) 1/1.8</b>
Test Procedure	Acceptance Criteria	Significant Test Data
<p>The tests should be carried out if the lifebuoy is intended for quick release with a light and smoke signal.</p> <p>The lifebuoy should be arranged in a manner simulating its installation on a ship for release from the navigating bridge.</p> <p>A lifebuoy light and smoke signal should be attached to the lifebuoy in the manner recommended by the manufacturers.</p>	<p>The lifebuoy should be released and should activate both the light and the smoke signal.</p> <p>The weight of the lifebuoy should be at least 4 kg.</p>	<p>Lifebuoy No.</p> <p>Type / description of quick activating arrangement:</p> <p>Type of light and smoke signal:</p> <p>Light activated? Passed/ Failed</p> <p>Smoke activated? Passed/ Failed,</p> <p>Weight of the lifebuoy _____ kg</p> <p>Length of the line connected to the lifebuoy _____ m</p> <p>Passed _____ Failed _____</p> <p>Comments/Observations</p>

## 2.1.2 LIFEBUOY SELF-IGNITING LIGHTS EVALUATION AND TEST REPORT

**Remark:** If a lifebuoy self-igniting light is a combined light/smoke signal it should be treated as a sole lifebuoy self-igniting light.

- 2.1.2.0 Quality assurance
- 2.1.2.1 General information
  - 2.1.2.1.1 General data and specifications
  - 2.1.2.1.2 Submitted drawings, reports and documents
- 2.1.2.2 Visual inspection
  - 2.1.2.2.1 Approval marking
  - 2.1.2.2.2 Expiry marking
  - 2.1.2.2.3 Additional markings
  - 2.1.2.2.4 Electrical short circuit protection
  - 2.1.2.2.5 Construction and materials
  - 2.1.2.2.6 Colour of lifebuoy light
- 2.1.2.3 Temperature cycling test
- 2.1.2.4 Light tests
- 2.1.2.5 Chromaticity test
- 2.1.2.6 Rain test and watertightness test
- 2.1.2.7 Case resistance test
- 2.1.2.8 Lens drop test
- 2.1.2.9 Floatation test
- 2.1.2.10 Drop test
- 2.1.2.11 Fitting test
- 2.1.2.12 Release and operation test
- 2.1.2.13 Vibration test
- 2.1.2.14 Mould growth test
- 2.1.2.15 Corrosion and seawater resistance test
- 2.1.2.16 Solar radiation test
- 2.1.2.17 Test for oil resistance
- 2.1.2.18 Fire test

**2.1.2    LIFEBOUY SELF-IGNITING LIGHTS**  
**EVALUATION AND TEST REPORT**

<b>Manufacturer</b>	
<b>Type</b>	
<b>Date</b>	
<b>Place</b>	
<b>Name Surveyor printed</b>	
<b>Signature</b>	
<b>Approving Organization</b>	

<b>Lifebuoy self-igniting lights</b>	Manufacturer: _____ Model: _____ Lot/Serial Number: _____	Date: _____ Time: _____ Surveyor: _____ Organization: _____
<b>2.1.2.0 Quality assurance</b>	<b>Regulations: MSC.81(70) 2/1.1, 1.2</b>	
<p>Except where all appliances of a particular type are required by chapter III of the International Convention for the Safety of Life at Sea, 1974, as amended, or the International Life-Saving Appliance (LSA) Code, to be inspected, representatives of the Administration should make random inspection of manufacturers to ensure that the quality of life-saving appliances and the materials used comply with the specification of the approved prototype life-saving appliance.</p> <p>Manufacturers should be required to institute a quality control procedure to ensure that life-saving appliances are produced to the same standard as the prototype life-saving appliance approved by the Administration and to keep records of any production tests carried out in accordance with the Administration's instructions.</p>	Quality Assurance Standard Used:  Quality Assurance Procedure:  Quality Assurance Manual:	Passed/ Failed  Passed/ Failed  Passed/ Failed

<b>Lifebuoy self-igniting lights</b>	Manufacturer: _____ Model: _____ Lot/Serial Number: _____	Date: _____ Time: _____ Surveyor: _____ Organization: _____
<b>2.1.2.1.1 General data and specifications</b>		<b>Regulations: LSA Code; MSC.81(70)</b>
General Information	Lifejacket Lifebuoy Light Dimensions	Lifejacket Lifebuoy Light Weight
TYPE OF SWITCHING  FLASHING LIGHT  STEADY LIGHT		Details of Bulb, Battery & Voltages:  Comments/Observations







2.1.2.2 Visual Inspection (continued)		Regulations: LSA Code 1.2.2.1/1.2.2.6/1.2.2.9/1.2.2.10/1.2.3	
Test Procedure	Acceptance Criteria	Significant Test Data	
Construction and materials	The lifebuoy self-igniting lights should: - be constructed with proper workmanship and materials.	<u>Results:</u> PASS:	FAIL:
Colour of lifebuoy light	- be of an international or vivid reddish orange, or a comparably highly visible colour on all parts where this will assist detection at sea	PASS:	FAIL:
		Comments/Observations	

<b>Lifebuoy self-igniting lights</b>	Manufacturer: _____	Date: _____ Time: _____
	Model: _____	Surveyor: _____
	Lot/Serial Number: _____	Organization: _____

Lifebuoy self-igniting light testing flow chart

**Visual Inspection  
(all 13 lights)  
2.1.2.1**

light 1 temp cycle test 2.1.2.3	then light 1 performs Light test (hot) 2.1.2.4	light 1 then performs Chromaticity Test 2.1.2.5
light 2 temp cycle test 2.1.2.3	then light 2 performs Light test (cold) 2.1.2.4	light 2 then performs Chromaticity Test 2.1.2.5
light 3 temp cycle test 2.1.2.3		
light 4 Case Resistance Test 2.1.2.7		
light 5 Lens Drop Test 2.1.2.8 (if fitted)		
light 6 24 hr Floatation Test 2.1.2.9		
light 7 30 m drop test (x 2) 2.1.2.10	light 7 then performs Fitting Test 2.1.2.11	light 7 then performs Release/Operation Test 2.1.2.12
light 8 Vibration Test 2.1.2.13		
light 9 Mould growth test (may be waived) 2.1.2.14		
light 10 corrosion and sea water resistance test 2.1.2.15		
light 11 Solar radiation test (may be waived) 2.1.2.16		
light 12 Oil resistance test 2.1.2.17		
light 13 Fire test 2.1.2.18		

<b>Lifebuoy self-igniting lights</b>	Manufacturer: _____ Model: _____ Lot/Serial Number: _____	Date: _____ Time: _____ Surveyor: _____ Organization: _____
<b>2.1.2.3 Temperature cycling test</b>		<b>Regulations: LSA Code 1.2.2.2; MSC.81(70) 1/ 1.2, 1.2.1, 1.2.2, 10.2, 10.2.1</b>
Test Procedure	Acceptance Criteria	Significant Test Data
<p>Three lifebuoy self-igniting lights should be alternately subjected to surrounding temperatures - 30°C and at least +65°C. These alternating cycles need not follow immediately after each other and the following procedure, repeated for a total of not less than 10 cycles, is acceptable:</p> <ol style="list-style-type: none"> <li>1. an 8 h exposure at a minimum temperature of +65°C to be completed in one day; and</li> <li>2. the specimens removed from the warm chamber that same day and left exposed under ordinary room conditions at a temperature of 20°C ± 3°C until the next day;</li> <li>3. an 8 h exposure at a maximum temperature of -30°C to be completed the next day; and</li> <li>4. the specimens removed from the cold chamber that same day and left exposed under ordinary room conditions at a temperature of 20°C ± 3°C until the next day.</li> </ol>	<p>The lifebuoy self-igniting lights should not be damaged in stowage throughout the air temperature range -30°C to +65°C. The lifebuoy self-igniting lights should show no sign of loss of rigidity under high temperatures and, after the tests, should show no sign of damage such as shrinking, cracking, swelling, dissolution or change of mechanical qualities and should function after the test.</p>	<p><u>Results:</u></p> <p>Attach temperature cycling chart to record times spent at each temperature.</p> <p>PASS: _____ FAIL: _____</p> <p>Comments/Observations</p>

<b>Lifebuoy self-igniting lights</b>	Manufacturer: _____ Model: _____ Lot/Serial Number: _____	Date: _____ Time: _____ Surveyor: _____ Organization: _____
<b>2.1.2.3 Temperature cycling test – Test data</b>		<b>Regulations: LSA Code I/1.2.2; MSC.81(70) 1/1.2</b>
	<b>HOT CYCLE</b>	<b>COLD CYCLE</b>
Cycle 1	Date In: _____ Time In: _____ Temperature: _____ °C Date Out: _____ Time Out: _____ Duration: _____ hours	Date In: _____ Time In: _____ Temperature: _____ °C Date Out: _____ Time Out: _____ Duration: _____ hours
Cycle 2	Date In: _____ Time In: _____ Temperature: _____ °C Date Out: _____ Time Out: _____ Duration: _____ hours	Date In: _____ Time In: _____ Temperature: _____ °C Date Out: _____ Time Out: _____ Duration: _____ hours
Cycle 3	Date In: _____ Time In: _____ Temperature: _____ °C Date Out: _____ Time Out: _____ Duration: _____ hours	Date In: _____ Time In: _____ Temperature: _____ °C Date Out: _____ Time Out: _____ Duration: _____ hours
Cycle 4	Date In: _____ Time In: _____ Temperature : _____ °C Date Out: _____ Time Out: _____ Duration: _____ hours	Date In: _____ Time In: _____ Temperature: _____ °C Date Out: _____ Time Out: _____ Duration: _____ hours
Cycle 5	Date In: _____ Time In: _____ Temperature : _____ °C Date Out: _____ Time Out: _____ Duration: _____ hours	Date In: _____ Time In: _____ Temperature: _____ °C Date Out: _____ Time Out: _____ Duration: _____ hours
Cycle 6	Date In: _____ Time In: _____ Temperature: _____ °C Date Out: _____ Time Out: _____ Duration: _____ hours	Date In: _____ Time In : _____ Temperature : _____ °C Date Out: _____ Time Out: _____ Duration: _____ hours
Cycle 7	Date In: _____ Time In: _____ Temperature: _____ °C Date Out: _____ Time Out: _____ Duration: _____ hours	Date In: _____ Time In: _____ Temperature: _____ °C Date Out: _____ Time Out: _____ Duration: _____ hours
Cycle 8	Date In: _____ Time In: _____ Temperature: _____ °C Date Out: _____ Time Out: _____ Duration: _____ hours	Date In: _____ Time In: _____ Temperature: _____ °C Date Out: _____ Time Out: _____ Duration: _____ hours
Cycle 9	Date In: _____ Time In: _____ Temperature: _____ °C Date Out: _____ Time Out: _____ Duration: _____ hours	Date In: _____ Time In: _____ Temperature: _____ °C Date Out: _____ Time Out: _____ Duration: _____ hours
Cycle 10	Date In: _____ Time In: _____ Temperature: _____ °C Date Out: _____ Time Out: _____ Duration: _____ hours	Date In: _____ Time In: _____ Temperature: _____ °C Date Out: _____ Time Out: _____ Duration: _____ hours

<b>Lifebuoy self-igniting lights</b>	Manufacturer: _____ Model: _____ Lot/Serial Number: _____	Date: _____ Time: _____ Surveyor: _____ Organization: _____
<b>2.1.2.4 Light tests</b>		<b>Regulations: LSA Code 2.1.2/2.1.2.2/2.1.2.3; MSC.81(70) 1/ 10.2.2, 10.4, 10.4.9</b>
Test Procedure	Acceptance Criteria	Significant Test Data
<p>One lifebuoy self-igniting light which has passed the temperature cycling test should be taken from a stowage temperature of -30°C and then be operated immersed in seawater at a temperature of -1°C, another lifebuoy self-igniting light which has passed the temperature cycling test should be taken from a stowage temperature of +65°C and be operated immersed in seawater at a temperature of +30°C, and a third light should be taken from ordinary room condition and operated immersed in fresh water at ambient temperature. At the end of the first hour of operation the lifebuoy self-igniting lights should be immersed to a depth of 1 m for 1 min.</p> <p>If the voltage at 5 min of operation is lower than the recorded voltage at the end of life it is permissible to use a lamp from the same build standard for the light output test. Using the lowest recorded voltage, a light output test can be carried out as described below. The voltage of the 3 test units should be monitored continuously for 2 h. To make sure that all the test units provide a luminous intensity of not less than 2 cd in all directions of the upper hemisphere for 2 h operation, the following test should be performed:</p>	<p>After immersion, all the lifebuoy self-igniting lights should not be extinguished and should continue operating for at least an hour longer.</p> <p>All of the lights should be of white colour and they should continue to provide a luminous intensity of not less than 2 cd in all directions of the upper hemisphere or, in the case of a flashing light, flash at a rate of not less than 50 flashes and not more than 70 flashes per minute with at least the corresponding effective luminous intensity of not less than 2 cd for at least 2 h. (see formula below to calculate the effective luminous intensity.)</p> <p>The effective luminous intensity is to be found from the formula:</p> $\left( \frac{\int_{t_1}^{t_2} I dt}{0.2 + (t_2 - t_1)} \right)_{max}$ <p>where:</p> <p>I is the instantaneous intensity, 0.2 is the Blondel-Rey constant and t<sub>1</sub> and t<sub>2</sub> are time - limits of integration in seconds.</p>	<p><u>Results:</u></p> <p>All luminous intensity data is to be attached here.</p> <p>PASS: _____ FAIL: _____</p> <p>Comments/Observations</p>

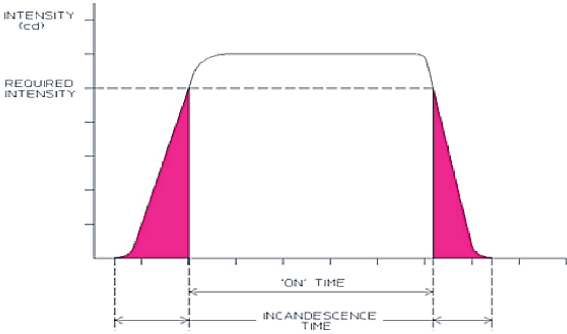
<b>Lifebuoy self-igniting lights</b>	Manufacturer: _____ Model: _____ Lot/Serial Number: _____	Date: _____ Time: _____ Surveyor: _____ Organization: _____
<b>2.1.2.4 Light tests (continued)</b>		<b>Regulations: LSA Code 2.1.2/2.1.2.2/2.1.2.3; MSC.81(70) 1/ 10.2.2, 10.4, 10.4.9</b>
<b>Test Procedure</b>	<b>Acceptance Criteria</b>	<b>Significant Test Data</b>
<p>It must be demonstrated that all the test unit lights reach the required luminous intensity in all directions of the upper hemisphere when using a photometer which is calibrated to the photometric standards of the appropriate National or State Standard Institute (Note: CIE Publ. No. 70 contains further information.). Luminous intensity of all test unit lights should be measured by a photometer directed at the center of the light source with the test light on a rotating table. Luminous intensity should be measured in a horizontal direction at the level of the center of the light source and continuously recorded through a 360° rotation. The first measurement should be taken at 0° (horizontal) and should continue to be taken in the azimuth angle at 5° intervals to a single measurement at 90° (vertical).</p> <p>Luminous intensity should be measured in a vertical direction, beginning at the center of the light source at the point of lowest recorded light output, and continuously recorded through an arc of 180°.</p>	<p>Flashing lights with a flash duration of not less than 0.3 s may be considered as fixed/steady lights for the measurement of their luminous intensity. Such lights should provide the required luminous intensity in all directions of the upper hemisphere. The time interval between switching on and reaching the required luminous intensity (incandescence time) and all time spent below the required luminous intensity when the light switches off should be disregarded (see figure 10.4.1.)</p> <p>Figure 10.4.1 "On-time" measurement diagram</p> 	<p>Passed _____ Failed _____</p> <p>Comments/Observations</p> <p>All lights operated for first one hour and immersed to a depth of 1m for 1 min as mentioned below</p> <ol style="list-style-type: none"> <li>1) Light 1, taken from -30°C, immersed in seawater temperature -10°C</li> <li>2) Light 2, taken from +65°C, immersed in seawater of +30°C</li> <li>3) Light 3, taken from ordinary temperature, immersed in fresh water at ambient temperature</li> </ol> <p>After immersion as mentioned above, all lifebuoy self-igniting lights continue operated for at least an hour longer: Yes/ No</p> <p>Comments/Observations</p>

<b>Lifebuoy self-igniting lights</b>	Manufacturer: _____ Model: _____ Lot/Serial Number: _____	Date: _____ Time: _____ Surveyor: _____ Organization: _____
<b>2.1.2.5 Chromaticity test</b>		<b>Regulations: LSA Code 2.1.2.2; MSC.81(70) 1/10.2.2, 10.4, 10.4.10</b>
Test Procedure	Acceptance Criteria	Significant Test Data
<p>All measured data of luminous intensity and voltage should be documented.</p> <p>One lifebuoy self-igniting light which has passed the light tests should be tested for chromaticity to determine that it lies within the boundaries of the area "white" of the diagram specified for each colour by the International Commission on Illumination (CIE). The chromaticities of the lifebuoy self-igniting light should be measured by means of colorimetric measurement equipment which is calibrated to the appropriate National or State Standards Institute (Note: CIE Publ. No.15.2 contains further information.). Measurement on at least four points of the upper hemisphere should be taken.</p>	<p>The measured chromaticity coordinates should fall within the boundaries of the area of the diagram as per CIE. The boundaries of the area for white lights are given by the following corner coordinates:</p> <p>x 0.500 0.500 0.440 0.300 0.300 0.440  y 0.382 0.440 0.433 0.344 0.278 0.382</p> <p>(International Standard on Colours of Light Signals, with colour tables to be developed by CIE.)</p>	<p><u>Results:</u>  All chromaticity data is to be attached here.</p> <p>PASS: _____ FAIL: _____</p> <p>Comments/Observations</p>

<b>Lifebuoy self-igniting lights</b>	Manufacturer: _____ Model: _____ Lot/Serial Number: _____	Date: _____ Time: _____ Surveyor: _____ Organization: _____
<b>2.1.2.6 Rain test and Watertightness Test</b>		<b>Regulations: LSA Code 1.2.2.8; MSC.81(70) 1/ 10.2.5, 10.4.7</b>
<b>Test Procedure</b>	<b>Acceptance Criteria</b>	<b>Significant Test Data</b>
<p>One lifebuoy self-igniting light which has passed the temperature cycling test should be subjected to the rain test according to IEC 60945:2002, paragraph 8.8. After having passed the rain test, the lifebuoy self-igniting light and its complete power source should be immersed horizontally under not less than 300 mm of fresh water for at least 24 h.</p> <p>After that test, the lifebuoy self-igniting light should be tested for function. After having tested its function, and if it is an electric light, it should be disassembled and examined for the presence of water.</p> <p>Automatic activated version should be prevented from switching during these tests.</p>	<p>The lifebuoy self-igniting light should be rot-proof and, if it is to be used in a seaway, be capable of satisfactory operation in that environment.</p> <p>The lifebuoy self-igniting light should function after immersion under water.</p> <p>The lifebuoy self-igniting light should comply with the requirements of IEC 60945:2002, paragraph 8.8.2.</p> <p>There should be no evidence of water inside the lifebuoy self-igniting light.</p>	<p><u>Results:</u></p> <p>PASS: _____ FAIL: _____</p> <p>Comments/Observations</p>



<b>Lifebuoy self-igniting lights</b>	Manufacturer: _____	Date: _____ Time: _____
	Model: _____ Lot/Serial Number: _____	Surveyor: _____ Organization: _____
<b>2.1.2.7 Case resistance test</b>		<b>Regulations: MSC.81(70) 1/ 10.2.7</b>
Test Procedure	Acceptance Criteria	Significant Test Data
One lifebuoy self-igniting light should be placed on its side on a rigid surface and a steel sphere having a mass of 500 g should be dropped from a height of 1.3 m on to the case at least three times. The sphere should strike the case near its centre on one drop, approximately 12 mm from one end of the case on another drop and approximately 12 mm from the other end of the case on the third drop.	The case should not break or crack, or be distorted in a way that would affect its watertightness.  The lifebuoy self-igniting light should function after the test.	<u>Results:</u>  PASS: _____ FAIL: _____  Comments/Observations
<b>2.1.2.8 Lens drop test</b>		<b>Regulations: MSC.81(70) 1/ 10.2.6</b>
Test Procedure	Acceptance Criteria	Significant Test Data
If a lifebuoy self-igniting light has a lens, it should be subjected to the dome drop test.  The lifebuoy self-igniting light should be cooled to -18°C and dropped twice from a height of 1 m on to a rigidly mounted steel plate or concrete surface. The distance should be measured from the top of the lens to the impact surface. The lifebuoy self-igniting light should strike the surface on the top centre of the lens.	The lens should not break or crack.  The lifebuoy self-igniting light should function after the test.	<u>Results:</u>  PASS: _____ FAIL: _____  Comments/Observations

2.1.2.9 Floatation test		Regulations: LSA Code 1.2.2.8; MSC.81(70) 1/ 10.2.4
Test Procedure	Acceptance Criteria	Significant Test Data
<p>One lifebuoy self-igniting light should be subjected to the floatation test. If the unit has an automatic activation, it should be disabled during this test.</p> <p>The lifebuoy self-igniting light should be allowed to float in water in its normal operating position for 24 h.</p> <p>If the lifebuoy self-igniting light is an electric light, it should be disassembled at the end of the tests and examined for the presence of water.</p>	<p>The lifebuoy self-igniting light should be capable of satisfactory operation in a seaway.</p> <p>The lifebuoy self-igniting light should function after the test and there should be no evidence of water inside the lifebuoy self-igniting light.</p>	<p><u>Results:</u></p> <p>PASS: <span style="float: right;">FAIL:</span></p> <p>Comments/Observations</p>

<b>Lifebuoy self-igniting lights</b>	Manufacturer: _____	Date: _____ Time: _____
	Model: _____ Lot/Serial Number: _____	Surveyor: _____ Organization: _____
<b>2.1.2.10 Drop test</b>		<b>Regulations: LSA Code 2.1.2.4/2.1.1.6; MSC.81(70) 1/ 1.3, 10.2.3</b>
<b>Test Procedure</b>	<b>Acceptance Criteria</b>	<b>Significant Test Data</b>
<p>One lifebuoy self-igniting light which has passed the visual inspection should be subjected to the drop test.</p> <p>The lifebuoy self-igniting light should be subjected to at least two drop tests as follows:</p> <p>The lifebuoy self-igniting light should be dropped into water, such that the lower edge of the light is at a height at which it is intended to be stowed on ships in their lightest sea going condition, or 30 m, whichever is greater.</p> <p>The lifebuoy self-igniting light should be dropped twice, first by itself and then attached to a lifebuoy.</p> <p>On sea activated lights this test should be carried out with the sealing plugs fitted to prevent the ingress of water which will cause the light to operate.</p>	<p>The lifebuoy self-igniting light should withstand this test without impairing either its operating capability or that of its attached components.</p> <p>The lifebuoy self-igniting light should not suffer damage and should operate satisfactorily after each drop.</p>	<p><u>Results:</u></p> <p>PASS: _____ FAIL: _____</p> <p>Comments/Observations</p>
<b>2.1.2.11 Fitting test</b>		<b>Regulations: MSC.81(70) 1/ 10.2.8</b>
<b>Test Procedure</b>	<b>Acceptance Criteria</b>	<b>Significant Test Data</b>
<p>The lifebuoy self-igniting light which has passed the drop test should be subjected to the fitting test.</p> <p>A force of 225 N should be applied to the fitting and lanyard that attaches the lifebuoy self-igniting light to a lifebuoy.</p> <p>After having passed the fitting test the light should be subjected to the release and operation test.</p>	<p>Neither the fitting and lanyard nor the lifebuoy self-igniting light should be damaged as a result of this test.</p> <p>The lifebuoy self-igniting light should function after the test.</p>	<p><u>Results:</u></p> <p>PASS: _____ FAIL: _____</p> <p>Comments/Observations</p>

<b>Lifebuoy self-igniting lights</b>	Manufacturer: _____	Date: _____ Time: _____
	Model: _____ Lot/Serial Number: _____	Surveyor: _____ Organization: _____
<b>2.1.2.12 Release and operation test</b>		<b>Regulations: LSA Code 2.1.1.7; MSC.81(70) 1/1.8</b>
<b>Test Procedure</b>	<b>Acceptance Criteria</b>	<b>Significant Test Data</b>
One lifebuoy intended for quick release with the lifebuoy self-igniting light which has passed the fitting test and a smoke signal should be given this test. The chemical material intended to produce the smoke should be substituted by an equivalent non- dangerous material. The lifebuoy should be arranged in a manner simulating its installation on a ship for release from the navigating bridge. The lifebuoy self-igniting light and a smoke signal should be attached to the lifebuoy in the manner recommended by the manufacturer. The lifebuoy should be released.	The lifebuoy should activate the lifebuoy self-igniting light.	<u>Results:</u>  PASS: _____ FAIL: _____  Comments/Observations
<b>2.1.2.13 Vibration test</b>		<b>Regulations: LSA Code 1.2.2.1/1.2.2.8; MSC.81(70) 1/ 10.4, 10.4.1</b>
<b>Test Procedure</b>	<b>Acceptance Criteria</b>	<b>Significant Test Data</b>
One lifebuoy self-igniting light which has passed the visual inspection should be subjected to a vibration test according to IEC 60945:2002 paragraph 8.7.	The lifebuoy self-igniting light should be constructed with proper workmanship and materials.  The lifebuoy self-igniting light should function after the test.	<u>Results:</u>  PASS: _____ FAIL: _____  Comments/Observations

<b>Lifebuoy self-igniting lights</b>	Manufacturer: _____ Model: _____ Lot/Serial Number: _____	Date: _____ Time: _____ Surveyor: _____ Organization: _____
<b>2.1.2.14 Mould growth test</b>		<b>Regulations: LSA Code 1.2.2.4; MSC.81(70) 1/10.4, 10.4.2</b>
Test Procedure	Acceptance Criteria	Significant Test Data
<p>One lifebuoy self-igniting light which has passed the visual inspection should be subjected to the mould growth test.</p> <p>The lifebuoy self-igniting light should be inoculated by spraying with an aqueous suspension of mould spores containing all the following cultures:</p> <p>Aspergillus niger; Aspergillus terreus; Aureobasidium pullulans; Paecilomyces variotii; Penicillium funiculosum; Penicillium ochrochloron; Scopulariopsis brevicaulis; and Trichoderma viride.</p> <p>The lifebuoy self-igniting craft light should then be placed in a mould growth chamber which should be maintained at a temperature of 29°C +/- 1°C and a relative humidity of not less than 95 %. The period of incubation should be 28 days. After this period the lifebuoy self-igniting light should be inspected.</p> <p>(Note: The mould growth test may be waived where the manufacturer is able to produce evidence that the external materials employed will satisfy the test.)</p>	<p>The lifebuoy self-igniting light should be rot-proof and not be unduly affected by fungal attack.</p> <p>There should be no mould growth visible to the naked eye and the lifebuoy self-igniting light should function after the test.</p>	<p><u>Results:</u></p> <p>PASS: _____ FAIL: _____</p> <p>Comments/Observations</p>

<b>Lifebuoy self-igniting lights</b>	Manufacturer: _____	Date: _____ Time: _____
	Model: _____ Lot/Serial Number: _____	Surveyor: _____ Organization: _____
<b>2.1.2.15 Corrosion and seawater resistance test</b>		<b>Regulations: LSA Code 1.2.2.4; MSC.81(70) 1/ 10.4, 10.4.4</b>
<b>Test Procedure</b>	<b>Acceptance Criteria</b>	<b>Significant Test Data</b>
<p>One lifebuoy self-igniting light which has passed the visual inspection should be subjected to a corrosion and seawater resistance test according to IEC 60945:2002, paragraph 8.12.</p> <p>(Note: .1 If there are no exposed metal parts the Corrosion and Seawater Resistance Test need not be conducted. .2 The Corrosion and Seawater Resistance Test may be waived where the manufacturer is able to produce evidence that the external metals employed will satisfy the test. .3 Automatic activated version should be prevented from switching during the test.)</p>	<p>The lifebuoy self-igniting light should be corrosion resistant and not be unduly affected by seawater.</p> <p>Furthermore, the lifebuoy self-igniting light should comply with the requirements of IEC 60945:2002, paragraph 8.12.2.</p> <p>There should be no undue deterioration of metal parts and the lifebuoy self-igniting light should function after the test.</p> <p>Where the exposed metal is part of the automatic switch sensor, the function test after the 28-day test cannot be done.</p>	<p><u>Results:</u></p> <p>PASS: _____ FAIL: _____</p> <p>Comments/Observations</p>
<b>2.1.2.16 Solar radiation test</b>		<b>Regulations: LSA Code 1.2.2.5; MSC.81(70) 1/ 10.4, 10.4.5</b>
<b>Test Procedure</b>	<b>Acceptance Criteria</b>	<b>Significant Test Data</b>
<p>One lifebuoy self-igniting light which has passed the visual inspection should be subjected to a solar radiation test according to IEC 60945:2002, paragraph 8.10.</p> <p>(Note: The solar radiation test may be waived where the manufacturer is able to produce evidence that the materials employed will satisfy the test, i.e. UV stabilized.)</p>	<p>The lifebuoy self-igniting light should be resistant to deterioration by sunlight.</p> <p>Furthermore, the mechanical properties and labels should be resistant to harmful deterioration by sunlight and the lifebuoy self-igniting light should function after the test.</p>	<p><u>Results:</u></p> <p>PASS: _____ FAIL: _____</p> <p>Comments/Observations</p>

<b>Lifebuoy self-igniting lights</b>	Manufacturer: _____	Date: _____ Time: _____
	Model: _____	Surveyor: _____
	Lot/Serial Number: _____	Organization: _____
<b>2.1.2.17 Test for oil resistance</b>		<b>Regulations: LSA Code 1.2.2.4; MSC.81(70) 1/ 10.4, 10.4.6</b>
<b>Test Procedure</b>	<b>Acceptance Criteria</b>	<b>Significant Test Data</b>
One lifebuoy self-igniting light which has passed the visual inspection should be subjected to the test for oil resistance according to IEC 60945:2002 paragraph 8.11. Automatic activated version should be prevented from switching during the test.	After this test the lifebuoy self-igniting light should not be unduly affected by oil and should show no sign of damage such as shrinking, cracking, swelling, dissolution or change of mechanical qualities.  The lifebuoy self-igniting light should function after the test.	<u>Results:</u>  PASS: _____ FAIL: _____  Comments/Observations
<b>2.1.2.18 Fire rest</b>		<b>Regulations: LSA Code 2.1.1.5; MSC.81(70) 1/ 10.4, 10.4.8</b>
<b>Test Procedure</b>	<b>Acceptance Criteria</b>	<b>Significant Test Data</b>
One lifebuoy self-igniting light which has passed the visual inspection should be subjected to a fire test. A test pan not less than 30 cm x 35 cm x 6 cm should be placed in an essentially draught-free area. Water should be put in the bottom of the test pan to a depth of at least 1 cm followed by enough petrol to make a minimum total depth of not less than 4 cm. The petrol should then be ignited and allowed to burn freely for at least 30 s. The lifebuoy self-igniting light should then be moved through the flames, facing them, with the lifebuoy self-igniting light not more than 25 cm above the top edge of the test pan so that the duration of exposure to the flames is at least 2 s.	The lifebuoy self-igniting light should not sustain burning or continue melting after being totally enveloped in a fire for a period of not less than 2 s and after being removed from the flames.  The lifebuoy self-igniting light should function after the test.	<u>Results:</u>  PASS: _____ FAIL: _____  Comments/Observations

### **2.1.3 LIFEBUOY SELF-ACTIVATING SMOKE SIGNALS EVALUATION AND TEST REPORT**

- 2.1.3.1 Submitted drawings, reports and documents
  - 2.1.3.1.1 Quality assurance
  - 2.1.3.1.2 Visual inspection
  - 2.1.3.1.3 General data and specification
- 2.1.3.2 Temperature cycling test
- 2.1.3.3 Low temperature conditioning test
- 2.1.3.4 High temperature conditioning test
- 2.1.3.5 Ambient temperature conditioning and drop test
- 2.1.3.6 Humidity conditioning
- 2.1.3.7 Water and corrosion resistance test
  - 2.1.3.7.1 Immersed for 24 h under 1 m
  - 2.1.3.7.2 10 cm immersion ready-to-fire for 5 mins. test
  - 2.1.3.7.3 Salt spray conditioning
- 2.1.3.8 Heptane test
- 2.1.3.9 Laboratory smoke obscuration test
- 2.1.3.10 Wave test
- 2.1.3.11 Attachment fitting strength test
- 2.1.3.12 Safety inspection



**2.1.3 LIFEBOUY SELF-ACTIVATING SMOKE SIGNALS  
EVALUATION AND TEST REPORT**

<b>Manufacturer</b>	
<b>Type/Model</b>	
<b>Date of Approval</b>	
<b>Place</b>	
<b>Name Surveyor printed</b>	
<b>Signature</b>	
<b>Approving Organization</b>	

<b>Lifebuoy self-activating smoke signals</b>	Manufacturer: _____	Date: _____ Time: _____
	Model: _____	Surveyor: _____
	Lot/Serial Number: _____	Organization: _____

**2.1.3.1 Submitted drawings, reports and documents**

Submitted drawings and documents			Status
Drawing No.	Revision No. & date	Title of drawing	

Submitted reports and documents			Status
Report/Document No.	Revision No. & date	Title of report / document	
		Maintenance Manual -	
		Operations Manual -	

<b>Lif buoy self-activating smoke signals</b>	Manufacturer: _____ Model: _____ Lot/Serial Number: _____	Date: _____ Time: _____ Surveyor: _____ Organization: _____
<b>2.1.3.1.1 Quality assurance</b>		<b>Regulations: - MSC.81(70) 2/1.1, 1.2</b>
<p>Except where all appliances of a particular type are required by Chapter III of the International Convention for the Safety of Life at Sea, 1974, as amended, or the international Life-Saving Appliance Code, to be inspected, representatives of the Administration should make random inspections of manufacturers to ensure that the quality of life-saving appliances and materials used comply with the specification of the approved prototype life-saving appliance.</p> <p>Manufacturers should be required to institute a quality control procedure to ensure that life-saving appliances are produced to the same standard as the prototype life-saving appliance approved by the Administration and to keep records of any production tests carried out in accordance with the Administration's instructions.</p>		<p>Quality Assurance Standard Used: -</p> <p>Quality Assurance Procedure: -</p> <p>Quality Assurance Manual: -</p> <p>Description of System.</p> <p>Quality Assurance System acceptable: Yes/No</p> <p>Comments/Observations</p>

<b>Lifebuoy self-activating smoke signals</b>	Manufacturer: _____ Model: _____ Lot/Serial Number: _____	Date: _____ Time: _____ Surveyor: _____ Organization: _____
<b>2.1.3.1.2 Visual inspection</b>		<b>Regulations: LSA Code I/1.2; MSC.81(70) 1/1.9 and 4.5</b>
Test Procedure	Acceptance Criteria	Significant Test Data
Visual examination  Approval markings  Operating instructions.  Outer casing.  Ignition System.  Fitted with light  Acceptable life	Lifebuoy Self-Activating Smoke Signal should: -  be clearly marked with approval information including the Administration which approved it, date of manufacture and expiry and operational restrictions, markings are to be indelible;  be provided with brief instructions or diagrams clearly illustrating the use of the lifebuoy self-activating smoke signal printed on the casing also the method of manual operation;  not depend on adhesive tapes or plastic envelopes for its water-resistant properties  be fitted with an integral means of ignition;  if fitted with lights be tested in accordance with the requirements of Lifebuoy Self-Igniting lights, section 10.2.  The administration should determine the period of acceptability of the unit which are subject to deterioration with age.	Passed _____ Failed _____  Passed _____ Failed _____  Passed _____ Failed _____  Passed _____ Failed _____  Passed _____ Failed _____  Comments/Observations

<b>Lifebuoy self-activating smoke signals</b>	Manufacturer: _____ Model: _____ Lot/Serial Number: _____	Date: _____ Time: _____ Surveyor: _____ Organization: _____
<b>2.1.3.1.3 General data and specifications</b>		<b>Regulations: LSA Code I/1.2 &amp; III/3.3; MSC.81(70) 1 /4.8</b>
General Information	Dimensions	Weight
Construction Material:  Casing: Top cover (If applicable):  Bottom Cover (If applicable):  Method of Ignition  Operational Safety Delay (if Applicable)  Number of lights (if Applicable)  Type of lens dome Amperage of Bulb Number of Batteries: _____ Voltage of Batteries: _____ Acceptable life of the item: _____ yrs	Dimensions:  Length of Casing: _____ Maximum Diameter of Casing: _____ Minimum Diameter of Casing _____	Design Weight: _____ Weight as Tested: _____ Weight of Smoke Material _____  Comments/Observations

**LIFEBUOY SELF-ACTIVATING SMOKE SIGNAL CONDITIONING & SEQUENCE TEST CHART**

TEST ITEMS CONDITIONING SEQUENCE									REFERENCES	REMARKS
	1-3	4-6	7-9	10-12	13-15	16-18	19-21	22		
Specimen No. ->									<b>MSC.81(70)</b>	
Measuring dimensions and mass	A	A	A	A	A	A	A	A		
Temperature cycling test (2.1.3.2)	B	B	B						1.9.1 & 1.2.1.	
Low temperature conditioning (2.1.3.3)	C								1.9.2	
High temperature conditioning (2.1.3.4)		C							1.9.2	
Ambient temperature conditioning (2.1.3.5)			C						1.9.3	
Operate Immersed under 25mm for 10 secs (2.1.3.4)	C	C							1.9.2	
Humidity conditioning (2.1.3.6)				C					1.9.4 & 4.2.4	
1 metre for 24 hours (2.1.3.7.1)					C				1.9.4 & 4.3.1	
Salt water spray (2.1.3.7.2)						C			1.9.4 & 4.3.3	
Safety inspection (2.1.3.12)	D	D	D	D	D	D	D	D	4.5 & 1.9.4	
Operation at ambient temperature			E		E	E	E	E	1.9.3, 4.3.1	

**LIFEBUOY SELF-ACTIVATING SMOKE SIGNAL CONDITIONING & SEQUENCE TEST CHART (continued)**

Specimen No. ->	1-3	4-6	7-9	10-12	13-15	16-18	19-21	22	References	Remarks
Operate at conditioning Temperature	E	E		E					1.9.2, 4.2.4	
Heptane test (2.1.3.8)							F		1.9.4 & 4.8.2	
Attachment fitting strength (2.1.3.11)	F	F							10.2.8 & 1.9.6	May be carried out by an independent laboratory acceptable to the administration and report submitted. Use specimens 1 and 4.
Wave height test (2.1.3.10)								F	1.9.5	
30 m drop test (2.1.3.5)			H						1.9.3	
Smoke colour and emission time 15 minutes minimum	G	G	G	G	G	G	G	G	1.9.2 & 1.9.3	
Smoke obscuration (2.1.3.9)									4.8.3 & 1.9.4	May be carried out by an independent laboratory acceptable to the administration and report submitted.

Note: The letters in the above 'boxes' refer to the sequence of testing of each specimen lifebuoy self-activating smoke signal.

<b>Lifebuoy self-activating smoke signals</b>	Manufacturer: _____ Model: _____ Lot/Serial Number: _____	Date: _____ Time: _____ Surveyor: _____ Organization: _____																											
<b>2.1.3.2 Temperature cycling test</b>		<b>Regulations: LSA Code I/1.2.2; MSC.81(70) I/1.2.1</b>																											
Test Procedure	Acceptance Criteria	Significant Test Data																											
<p>Nine self-activating smoke signals should be alternately subjected to surrounding temperatures of -30°C and +65°C. These alternating cycles need not follow immediately after each other and the following procedure, repeated for a total of 10 cycles, is acceptable:</p> <ol style="list-style-type: none"> <li>1. an 8 h exposure at a minimum temperature of +65°C to be completed in one day; and</li> <li>2. the specimens removed from the warm chamber that same day and left exposed under ordinary room conditions at a temperature of 20°C ± 3°C until the next day;</li> <li>3. an 8 h exposure at a maximum temperature -30°C to be completed the next day; and</li> <li>4. the specimen removed from the cold chamber that same day and left exposed under ordinary room conditions at a temperature of 20°C ± 3°C until the next day.</li> </ol>	<p>After 10 cycles each specimen should be inspected and should show no sign of damage such as shrinking, cracking, swelling, dissolution or change of mechanical properties.</p>	<p><u>Specimen No.</u></p> <table style="width:100%; border-collapse: collapse;"> <tr> <td style="width:5%; text-align: right;">1.</td> <td style="width:60%;">Passed _____</td> <td style="width:35%;">Failed _____</td> </tr> <tr> <td style="text-align: right;">2.</td> <td>Passed _____</td> <td>Failed _____</td> </tr> <tr> <td style="text-align: right;">3.</td> <td>Passed _____</td> <td>Failed _____</td> </tr> <tr> <td style="text-align: right;">4.</td> <td>Passed _____</td> <td>Failed _____</td> </tr> <tr> <td style="text-align: right;">5.</td> <td>Passed _____</td> <td>Failed _____</td> </tr> <tr> <td style="text-align: right;">6.</td> <td>Passed _____</td> <td>Failed _____</td> </tr> <tr> <td style="text-align: right;">7.</td> <td>Passed _____</td> <td>Failed _____</td> </tr> <tr> <td style="text-align: right;">8.</td> <td>Passed _____</td> <td>Failed _____</td> </tr> <tr> <td style="text-align: right;">9.</td> <td>Passed _____</td> <td>Failed _____</td> </tr> </table> <p>Comments/Observations</p> <p>Passed _____ Failed _____</p>	1.	Passed _____	Failed _____	2.	Passed _____	Failed _____	3.	Passed _____	Failed _____	4.	Passed _____	Failed _____	5.	Passed _____	Failed _____	6.	Passed _____	Failed _____	7.	Passed _____	Failed _____	8.	Passed _____	Failed _____	9.	Passed _____	Failed _____
1.	Passed _____	Failed _____																											
2.	Passed _____	Failed _____																											
3.	Passed _____	Failed _____																											
4.	Passed _____	Failed _____																											
5.	Passed _____	Failed _____																											
6.	Passed _____	Failed _____																											
7.	Passed _____	Failed _____																											
8.	Passed _____	Failed _____																											
9.	Passed _____	Failed _____																											



<b>Lifebuoy self-activating smoke signals</b>	Manufacturer: _____ Model: _____ Lot/Serial Number: _____	Date: _____ Time: _____ Surveyor: _____ Organization: _____		
<b>2.1.3.3 Low temperature conditioning test</b>		<b>Regulations: LSA Code I/1.2.2; MSC.81(70) 1/1.9.2</b>		
Test Procedure	Acceptance Criteria	Significant Test Data		
<p>After at least ten complete temperature cycles the first three smoke signals should be subjected to a temperature of -30°C for at least 48 h, then taken from this stowage temperature be activated and operated in seawater at a temperature of -1°C, and function effectively at that temperature.</p>	<p>The 3 specimens should function effectively.</p> <p>Each specimen should show no sign of damage such as shrinking, cracking, swelling, dissolution or change of mechanical properties after completing the -30°C conditioning.</p> <p>The signal should not ignite explosively or in a manner dangerous to persons close by, nor emit any flame during the entire smoke emission time of at least 15 min.</p> <p>The colour of the smoke should be orange as defined by sections 34, 48, 49 or 50 of the publication Colour: Universal Language and Dictionary of Names.*</p> <p>*Special Publication 440, National Bureau of Standards, Washington, DC 20402, USA.</p> <p>After the smoke signals have been emitting smoke for 7 minutes, the smoke-emitting ends of the smoke signals should be immersed to a depth of 25 mm for 10 s. On being released the smoke signals should continue to emit a steady quantity of smoke of a highly visible colour at a uniform rate for a period of not less than 15 minutes when floating in calm water.</p>	Specimen Number		
		1	2	3
		Condition after Conditioning (Pass/Fail)		
		Smoke emission time (min/sec)		
		Smoke emission quality (Pass/Fail)		
		Smoke colour (Pass/Fail)		
		Smoke emissions during submergence (Pass/Fail)		
		Comments/Observations		
		Passed _____ Failed _____		

<b>Lifebuoy self-activating smoke signals</b>	Manufacturer: _____ Model: _____ Lot/Serial Number: _____	Date: _____ Time: _____ Surveyor: _____ Organization: _____		
<b>2.1.3.4 High temperature conditioning test</b>		<b>Regulations: LSA Code I/1.2.2 and II/2.1.3; MSC.81(70) 1/1.9.2</b>		
Test Procedure	Acceptance Criteria	Significant Test Data		
<p>After at least 10 complete temperature cycles, the next three smoke signals should be subjected to a temperature of +65°C for at least 48 h, then taken from this stowage temperature be activated and operated in seawater at a temperature of +30°C, and function effectively at that temperature.</p>	<p>The 3 specimens should function effectively.</p> <p>Each specimen should show no sign of damage such as shrinking, cracking, swelling, dissolution or change of mechanical properties after completing the +65°C conditioning.</p> <p>The smoke signal should not ignite explosively or in a manner dangerous to persons close by nor emit any flame during the entire smoke emission time.</p> <p>After the smoke signals have been emitting smoke for 7 minutes, the smoke-emitting ends of the smoke signals should be immersed to a depth of 25 mm for 10 s. On being released the smoke signals should continue to emit a steady quantity of smoke of a highly visible colour at a uniform rate for a period of not less than 15 minutes when floating in calm water.</p> <p>The colour of the smoke should be orange as defined by sections 34, 48, 49 or 50 of the publication Colour: Universal Language and Dictionary of Names.*</p> <p>*Special Publication 440, National Bureau of Standards, Washington, DC 20402, USA.</p>	Specimen Number		
		4	5	6
		Condition after Conditioning (Pass/Fail)		
		Smoke emission time (min/sec)		
		Smoke emission quality (Pass/Fail)		
		Smoke colour (Pass/Fail)		
		Smoke emission during submergence (Pass/Fail)		
		Comments/Observations		
		Passed _____ Failed _____		

<b>Lifebuoy self-activating smoke signals</b>	Manufacturer: _____ Model: _____ Lot/Serial Number: _____	Date: _____ Time: _____ Surveyor: _____ Organization: _____		
<b>2.1.3.5 Ambient Temperature Conditioning &amp; Drop Test</b>		<b>Regulations: LSA Code I/1.2.2 &amp; II/2.1.1.6; MSC.81(70) 1/1.9.3</b>		
Test Procedure	Acceptance Criteria	Significant Test Data		
<p>After at least ten complete temperature cycles, the last three smoke signals taken from ordinary room conditions and attached by a line to a lifebuoy having a mass of not more than 4 kg should undergo the drop test into water prescribed in MSC.81(70) 1/1.3. The lifebuoy should have both a smoke signal and a lifebuoy light attached in the manner recommended by the manufacturers and be dropped from a quick-release fitting. The smoke signals should not be damaged and should function for a period of at least 15 min.</p> <p>A lifebuoy and the smoke signal should be dropped each into the water from the height at which they are intended to be stowed on ships in their lightest seagoing condition, or 30 m, whichever is the greater, without suffering damage</p> <p>The lifebuoy and smoke signals should be dropped from a quick release fitting used for housing the signals.</p>	<p>The 3 specimens should function effectively for a period of at least 15 min.</p> <p>Each specimen should show no sign of damage such as shrinking, cracking, swelling, dissolution or change of mechanical properties after completing the ordinary room conditions at a temperature of 20°C ± 3°C conditioning.</p> <p>The smoke signal should not ignite explosively or in a manner dangerous to persons close by nor emit any flame during the entire smoke emission time.</p> <p>The smoke signal should not be damaged after the drop test.</p> <p>The colour of the smoke should be orange as defined by sections 34, 48, 49 or 50 of the publication Colour: Universal Language and Dictionary of Names.*</p> <p>*Special Publication 440, National Bureau of Standards, Washington, DC 20402, USA.</p>	Specimen No.		
		7	8	9
		Condition after Conditioning (Pass/Fail)		
		Drop height (metre)		
		Smoke emission time (min/sec)		
		Smoke emission quality (Pass/Fail)		
		Smoke colour (Pass/Fail)		
		Smoke signal damaged after drop test (Pass/Fail)		
		Comments/Observations		
		Passed _____ Failed _____		

<b>Lifebuoy self-activating smoke signals</b>	Manufacturer: _____ Model: _____ Lot/Serial Number: _____	Date: _____ Time: _____ Surveyor: _____ Organization: _____		
<b>2.1.3.6 Humidity conditioning</b>		<b>Regulations: LSA Code I/1.2.2 &amp; II/2.1.3; MSC.81(70) 1/4.2.4, 1.9.4</b>		
Test Procedure	Acceptance Criteria	Significant Test Data		
<p>Three specimens of smoke signals should be subjected to a temperature of +65°C and 90% relative humidity for at least 96 h, followed by ten days at 20°C to 25°C at 65% relative humidity.</p> <p>After the humidity test the specimens should be subjected to the function test at ambient temperature.</p>	<p>The 3 specimens should function effectively.</p> <p>Each specimen should show no sign of damage such as shrinking, cracking, swelling, dissolution or change of mechanical properties after completing the temperature of +65°C and 90% relative humidity for at least 96 h, followed by ten days at 20°C to 25°C at 65% relative humidity conditioning.</p> <p>The smoke signal should not ignite explosively or in a manner dangerous to persons close by nor emit any flame during the entire smoke emission time.</p> <p>Each specimen should emit smoke of a highly visible colour at a uniform rate for a period of not less than 15 minutes when floating in calm water.</p> <p>The colour of the smoke should be orange as defined by sections 34, 48, 49 or 50 of the publication Colour: Universal Language and Dictionary of Names.*</p> <p>*Special Publication 440, National Bureau of Standards, Washington, DC 20402, USA.</p>	Specimen No.		
		10	11	12
		Condition after Conditioning (Pass/Fail)		
		Smoke emission time (min/sec)		
		Smoke emission quality (Continuous/Intermittent)		
		Smoke emission colour: (Passed/Failed)		
<p>Comments/Observations</p>          <p>Passed _____ Failed _____</p>				

<b>Lifebuoy self-activating smoke signals</b>	Manufacturer: _____ Model: _____ Lot/Serial Number: _____	Date: _____ Time: _____ Surveyor: _____ Organization: _____		
<b>2.1.3.7.1 Immersed for 24 h under 1 m</b>		<b>Regulations: LSA Code I/1.2.2 and II/2.1.3; MSC.81(70) 1/4.3.1, 1.9.4</b>		
Test Procedure	Acceptance Criteria	Significant Test Data		
<p>Three specimens of smoke signal should be immersed horizontally for 24 h under 1 m of water.</p> <p>After this test the specimens should be subjected to the function test at ambient temperature.</p>	<p>The three specimens should show no sign of damage such as shrinking, cracking, swelling, dissolution or change of mechanical properties.</p> <p>The signals should establish that it can be operated effectively without injury to the operator, or any person in close proximity, during firing or burning.</p> <p>The specimen signal should not ignite explosively or in a manner dangerous to persons close by, nor emit any flame during the entire smoke emission time. They should emit smoke of a highly visible colour at a uniform rate for a period of not less than 15 minutes when floating in calm water.</p> <p>The colour of the smoke should be orange as defined by sections 34, 48, 49 or 50 of the publication Colour: Universal Language and Dictionary of Names.*</p> <p>*Special Publication 440, National Bureau of Standards, Washington, DC 20402, USA.</p>	Specimen No.		
		13	14	15
		Condition after Conditioning (Pass/Fail)		
		Smoke emission time (min/sec)	Smoke emission quality (Continuous/Intermittent)	Smoke emission colour: Passed/Failed
		Comments/Observations		
		Passed _____ Failed _____		

<b>Lifebuoy self-activating smoke signals</b>	Manufacturer: _____ Model: _____ Lot/Serial Number: _____	Date: _____ Time: _____ Surveyor: _____ Organization: _____		
<b>2.1.3.7.2 10 cm immersion ready-to-fire for 5 mins. test</b>		<b>Regulations: LSA Code I/1.2.2 &amp; II/2.1.3; MSC.81(70) 1/4.3.2</b>		
Test Procedure	Acceptance Criteria	Significant Test Data		
<p>Three specimens of smoke signals should be made ready-to-fire, submerged in 10 cm of water for 5 min.</p> <p>The three signals should be activated at ambient temperature in accordance with the manufacturer's operating instructions.</p>	<p>The three specimens should show no sign of damage such as shrinking, cracking, swelling, dissolution or change of mechanical properties.</p> <p>The signals should establish that it can be operated effectively without injury to the operator, or any person in close proximity, during firing or burning.</p> <p>The specimen signal should not ignite explosively or in a manner dangerous to persons close by, nor emit any flame during the entire smoke emission time. They should emit smoke of a highly visible colour at a uniform rate for a period of not less than 15 minutes when floating in calm water.</p> <p>The colour of the smoke should be orange as defined by sections 34, 48, 49 or 50 of the publication Colour: Universal Language and Dictionary of Names.*</p> <p>*Special Publication 440, National Bureau of Standards, Washington, DC 20402, USA.</p>	Specimen No		
		16	17	18
		Condition after Conditioning (Pass/Fail)		
		Smoke emission time (min/sec)		
		Smoke emission quality (Continuous/Intermittent)		
		Smoke emission colour: Passed/Failed		
		Comments/Observations		
		Passed _____ Failed _____		

<b>Lifebuoy self-activating smoke signals</b>	Manufacturer: _____ Model: _____ Lot/Serial Number: _____	Date: _____ Time: _____ Surveyor: _____ Organization: _____		
<b>2.1.3.7.3 Salt spray conditioning</b>		<b>Regulations: LSA Code I/1.2.2 &amp; II/2.1.3; MSC.81(70) 1/1.9.4, 4.3.3</b>		
Test Procedure	Acceptance Criteria	Significant Test Data		
<p>Three specimens of smoke signals should be subjected to a salt spray (5% sodium chloride solution) at a temperature of +35±3°C for at least 100 h.</p> <p>The three signals should be activated at ambient temperature in accordance with the manufacturer's operating instructions.</p>	<p>The three specimens should show no sign of damage such as shrinking, cracking, swelling, dissolution or change of mechanical properties.</p> <p>The signals should establish that it can be operated effectively without injury to the operator, or any person in close proximity, during firing or burning.</p> <p>The specimen signal should not ignite explosively or in a manner dangerous to persons close by, nor emit any flame during the entire smoke emission time. They should emit smoke of a highly visible colour at a uniform rate for a period of not less than 15 minutes when floating in calm water.</p> <p>The colour of the smoke should be orange as defined by sections 34, 48, 49 or 50 of the publication Colour: Universal Language and Dictionary of Names.*</p> <p>*Special Publication 440, National Bureau of Standards, Washington, DC 20402, USA.</p>	Specimen No		
		19	20	21
		Condition after Conditioning (Pass/Fail)		
		Smoke emission time (min/sec)		
		Smoke emission quality (Continuous/Intermittent)		
Smoke emission colour: Passed/Failed				
Comments/Observations				
Passed _____ Failed _____				

<b>Lifbuoy self-activating smoke signals</b>	Manufacturer: _____ Model: _____ Lot/Serial Number: _____	Date: _____ Time: _____ Surveyor: _____ Organization: _____		
<b>2.1.3.8 Heptane test</b>		<b>Regulations: LSA Code I/1.2.2 &amp; II/2.1.3.1; MSC.81(70) 1/4.8.2, 1.9.4</b>		
Test Procedure	Acceptance Criteria	Significant Test Data		
<p>Three smoke signals should function in water covered by 2 mm layer of heptane floating on a layer of water. The smoke signal should be allowed to burn completely.</p>	<p>The three specimens should not ignite the heptane.</p> <p>The specimen signal should not ignite explosively or in a manner dangerous to persons close by, nor emit any flame during the entire smoke emission time.</p> <p>They should emit smoke of a highly visible colour at a uniform rate for a period of not less than 15 minutes when floating in calm water.</p> <p>The colour of the smoke should be orange as defined by sections 34, 48, 49 or 50 of the publication Colour: Universal Language and Dictionary of Names.*</p> <p>*Special Publication 440, National Bureau of Standards, Washington, DC 20402, USA.</p>	Specimen No		
		22	23	24
		Heptane ignition (Passed/Failed)		
		Smoke emission time (min/sec)		
		Smoke emission quality (Continuous/Intermittent)		
		Smoke emission colour: (Passed/Failed)		
Comments/Observations				
Passed _____ Failed _____				



<b>Lifebuoy self-activating smoke signals</b>	Manufacturer: _____ Model: _____ Lot/Serial Number: _____	Date: _____ Time: _____ Surveyor: _____ Organization: _____
<b>2.1.3.9 Laboratory smoke obscuration test</b>		<b>Regulations: LSA Code I/1.2.2 &amp; II/2.1.3; MSC.81(70) 1/4.8.3, 1.9.4</b>
Test Procedure	Acceptance Criteria	Significant Test Data
<p>The smoke density and colour of the smoke signal should be determined by laboratory testing conducted at a water temperature of +20°C to +25°C as follows:</p> <p>The smoke should be drawn through an apparatus consisting of a 190 mm diameter duct with a fan capable of producing an entrance air flow of 18.4 m<sup>3</sup>/min. By means of a light source with at least 10 cd on one side of the tunnel and a photoelectric cell on the other side the density of the passing smoke should be recorded. If the photocell picks up the total emitted light from the light source, then the smoke density is zero percent which means that no smoke is passing through the tunnel. The smoke density is then considered to be 100% when the photocell is not able to pick up any light of the light source through the passing smoke in the tunnel. From the amount of light which the photocell is able to pick up the smoke density should be calculated. Before each measurement, the light intensity of the 100% value should be checked. Each measurement should be recorded.</p>	<p>Smoke density should be at least 70% throughout the minimum emission time.</p> <p>The colour of the orange smoke should be evaluated by means of visual comparison, in daylight, to a colour comparison chart containing the range of acceptable orange colours. The colour comparison chart should have a gloss or matte finish, and consist of a series of at least five orange colour chips, covering the range from reddish orange (Munsell notation 8.75 R 6/14) to yellowish orange (Munsell notation 5 YR MAX) in gradual steps of hue, chroma, and lightness. The colour chips should be secured adjacent to one another, in order of progression from reddish orange to yellowish orange, and extend on at least one side to the edge of the chart. Each colour chip should be at least 50 mm x 100 mm in size.</p> <p>Note 1: A typical acceptable progression would be 8.75 R 6/14; 10 R 6/14; 1.25 YR 6/14; 3.75 YR MAX; 5 YR MAX.</p> <p>Note 2: ASTM D1535-97 specifies a method to convert between Munsell notation and CIE coordinates.</p>	<p>Laboratory Testing Report No. _____</p> <p>Report acceptable (Yes/No) _____</p> <p>Smoke obscuration rate achieved at -30°C _____ %</p> <p>Burning time of smoke signal _____ sec</p> <p>Smoke obscuration rate achieved at +20°C to +25°C _____ %</p> <p>Burning time of smoke signal _____ sec</p> <p>Smoke obscuration rate achieved at +65°C _____ %</p> <p>Burning time of smoke signal _____ sec</p> <p>Colour of smoke achieved _____</p> <p>Comments/Observations _____</p> <p>Passed _____ Failed _____</p>

<b>Lifebuoy self-activating smoke signals</b>	Manufacturer: _____ Model: _____ Lot/Serial Number: _____	Date: _____ Time: _____ Surveyor: _____ Organization: _____
<b>2.1.3.10 Wave test</b>		<b>Regulations: LSA Code I/1.2.2 &amp; II/2.1.3; MSC.81(70) 1/1.9.5</b>
<b>Test Procedure</b>	<b>Acceptance Criteria</b>	<b>Significant Test Data</b>
<p>A smoke signal should be tested in waves at least 300 mm high.</p>	<p>The specimen should function effectively and not be swamped.</p> <p>The smoke signal should not ignite explosively or in a manner dangerous to persons close by, nor emit any flame during the entire smoke emission time.</p> <p>It should emit smoke of a highly visible colour at a uniform rate for a period of not less than 15 minutes when subjected to waves of at least 300 mm high.</p> <p>The colour of the orange smoke should be evaluated by means of visual comparison, in daylight, to a colour comparison chart containing the range of acceptable orange colours. The colour comparison chart should have a gloss or matte finish, and consist of a series of at least five orange colour chips, covering the range from reddish orange (Munsell notation 8.75 R 6/14) to yellowish orange (Munsell notation 5 YR MAX) in gradual steps of hue, chroma, and lightness. The colour chips should be secured adjacent to one another, in order of progression from reddish orange to yellowish orange, and extend on at least one side to the edge of the chart. Each colour chip should be at least 50 mm x 100 mm in size.</p> <p>Note: A typical acceptable progression would be 8.75 R 6/14; 10 R 6/14; 1.25 YR 6/14; 3.75 YR MAX; 5 YR MAX. Note: ASTM D1535-97 specifies a method to convert between Munsell notation and CIE coordinates.</p>	<p><u>Specimen No. 25</u></p> <p>Smoke emission time _____ sec</p> <p>Smoke emission quality (Continuous/Intermittent)</p> <p>Smoke emission colour: Passed/Failed</p> <p>Comments/Observations</p> <p>Passed _____ Failed _____</p>



<b>Lifebuoy self-activating smoke signals</b>	Manufacturer: _____ Model: _____ Lot/Serial Number: _____	Date: _____ Time: _____ Surveyor: _____ Organization: _____
<b>2.1.3.12 Safety inspection</b>		<b>Regulations: LSA Code I/1.2.2, MSC.81(70) 1/ 1.9.4/ 4.5</b>
Test Procedure	Acceptance Criteria	Significant Test Data
<p>It should be established by visual inspection that the self-activating smoke signal:</p> <ol style="list-style-type: none"> <li>1. is indelibly marked with clear and precise instructions on how it should be operated and mounted and that the danger end can be identified by day or night;</li> <li>2. does not depend on adhesive tapes or plastic envelopes for its water resistant properties; and</li> <li>3. can be indelibly marked with means of determining its age.</li> </ol>	<p>Clear and precise operating and mounting instructions are marked on the smoke signal.</p> <p>Adhesive tapes or plastic envelopes are not used to maintain water-resistant properties.</p> <p>Date of manufacturing and date of expiry indelible printed on the outside.</p>	<p>Markings and identification of signal:</p> <p>Passed_____ Failed_____</p> <p>Water resistant without the use of envelopes or adhesive tape.</p> <p>Passed_____ Failed_____</p> <p>Smoke signal indelible date stamped</p> <p>Passed_____ Failed_____</p> <p>Comments/Observations</p>

## **2.2 LIFEJACKETS AND ASSOCIATED EQUIPMENT**

### **2.2.1 INHERENTLY BUOYANT LIFEJACKETS**

#### **EVALUATION AND TEST REPORT**

- 2.2.1.1 Submitted drawings, reports and documents
- 2.2.1.2 Quality assurance
- 2.2.1.3 Visual inspection
- 2.2.1.4 General data and specification
- 2.2.1.5 Temperature cycling test
- 2.2.1.6 Buoyancy test
- 2.2.1.7 Fire test
- 2.2.1.8 Oil resistance test
- 2.2.1.9 Tests of components other than buoyancy materials
- 2.2.1.10 Strength tests – Body or lifting loop strength tests
- 2.2.1.11 Strength tests – Shoulder lift test
- 2.2.1.12 Tests for lifejacket buoyancy material – Stability under temperature cycling
- 2.2.1.13 Tests for lifejacket buoyancy material – Compression and water absorption test
- 2.2.1.14 Tests for lifejacket buoyancy material – Tensile strength test
- 2.2.1.15 Donning test
- 2.2.1.16 Water performance tests – Preparation for water performance tests
- 2.2.1.17 Water performance tests – Righting tests
- 2.2.1.18 Water performance tests – Static balance measurements
- 2.2.1.19 Water performance tests – Jump and drop tests
- 2.2.1.20 Water performance tests – Stability test
- 2.2.1.21 Water performance tests – Swimming and water emergence test
- 2.2.1.22 Infant and children's lifejacket – Test subjects selection
- 2.2.1.23 Infant and children's lifejacket – Water performance tests – Righting test
- 2.2.1.24 Infant and children's lifejacket – Water performance tests – Static balance measurements

2.2.1.25 Children's lifejacket – Water performance tests – Jump and drop test

2.2.1.26 Infant and children's lifejacket – Water performance tests – Stability test

2.2.1.27 Infant and children's lifejacket – Mobility test

**2.2.1 INHERENTLY BUOYANT LIFEJACKETS  
EVALUATION AND TEST REPORT**

<b>Manufacturer</b>	
<b>Type</b>	
<b>Date</b>	
<b>Place</b>	
<b>Name Surveyor printed</b>	
<b>Signature</b>	
<b>Approving Organization</b>	

<b>Inherently buoyant lifejackets</b>	Manufacturer: _____	Date: _____ Time: _____
	Model: _____	Surveyor: _____
	Lot/Serial Number: _____	Organization: _____

**2.2.1.1 Submitted drawings, reports and documents**

Submitted drawings and documents			Status
Drawing No.	Revision No. & date	Title of drawing	
Submitted reports and documents			Status
Report/Document No.	Revision No. & date	Title of report / document	
		Maintenance Manual -	
		Operations Manual -	



<b>Inherently buoyant lifejackets</b>	Manufacturer: _____ Model: _____ Lot/Serial Number: _____	Date: _____ Time: _____ Surveyor: _____ Organization: _____
<b>2.2.1.2 Quality assurance</b>		<b>Regulations: - MSC.81(70) 2/1.1, 1.2</b>
<p>Except where all appliances of a particular type are required by Chapter III of the International Convention for the Safety of Life at Sea, 1974, as amended, or the international Life-Saving Appliance (LSA) Code, to be inspected, representatives of the Administration should make random inspections of manufacturers to ensure that the quality of life-saving appliances and materials used comply with the specification of the approved prototype life-saving appliance.</p> <p>Manufacturers should be required to institute a quality control procedure to ensure that life-saving appliances are produced to the same standard as the prototype life-saving appliance approved by the Administration and to keep records of any production tests carried out in accordance with the Administration's instructions.</p>		<p>Quality Assurance</p> <p>Standard Used: _____</p> <p>Quality Assurance Procedure: _____</p> <p>Quality Assurance Manual: _____</p> <p>Description of System.</p> <p>Quality Assurance System acceptable</p> <p>Yes _____ No _____</p> <p>Comments/Observations</p>

<b>Inherently buoyant lifejackets</b>	Manufacturer: _____ Model: _____ Lot/Serial Number: _____	Date: _____ Time: _____ Surveyor: _____ Organization: _____
<b>2.2.1.3 Visual inspection</b>		<b>Regulations: LSA Code I/1.2.2.1, 1.2.2.6, 1.2.2.7, 1.2.2.9, 1.2.3; LSA Code II/ 2.2.1.14, 2.2.1.5.3 &amp; 2.2.1.5.5, 2.2.1.10, 2.2.1.13, 2.2.1.16 &amp; 2.2.1.17</b>
Test Procedure	Acceptance Criteria	Significant Test Data
.1 Approval markings	Inherently buoyant lifejackets should:  be clearly marked with approval information including the Administration which approved it, date of manufacturer any operational restrictions, and (if an infant or child lifejacket) the appropriate symbol according to resolution A.760(18).	Passed _____                  Failed _____
.2 Retro-reflective tape	be fitted with approved patches of retro-reflective material with a total area of at least 400 cm <sup>2</sup> according to resolution A.658(16). In the case of a reversible lifejacket, the arrangement should be complied with no matter which way the lifejacket is put on. Such material should be placed as high on the lifejacket as possible.	Passed _____                  Failed _____
.3 Lifejacket light	have provision to be fitted with a light	Passed _____                  Failed _____
.4 Donning and comfort	be so constructed that it is capable of being worn inside out or is clearly capable of being worn in one way and, if donned incorrectly, it is not injurious to the wearer. It should also be comfortable to wear;	Passed _____                  Failed _____
.5 Whistle	be fitted with a whistle firmly secured by a lanyard to the lifejacket.	Passed _____                  Failed _____
.6 Colour of lifejacket	be of international or vivid reddish orange or a comparably highly visible colour.	Passed _____                  Failed _____

<p>.7 Buoyant Line &amp; Means to lift the wearer</p>	<p>A lifejacket shall be provided with a releasable buoyant line or other means to secure it to a lifejacket worn by another person in the water. A lifejacket shall be provided with a suitable means to allow a rescuer to lift the wearer from the water into a survival craft or a rescue boat.</p>	<p>Passed _____ Failed _____</p>
<p>.8 Oversized lifejacket</p>	<p>If an adult lifejacket is not designed to fit persons weighing up to 140 kg and with a chest girth of up to 1,750 mm, suitable accessories shall be available to allow it to be secured to such persons.</p>	<p>Passed _____ Failed _____ Comments/Observations</p>



<b>Inherently buoyant lifejackets</b>	Manufacturer: _____ Model: _____ Lot/Serial Number: _____	Date: _____ Time: _____ Surveyor: _____ Organization: _____
<b>2.2.1.5 Temperature cycling test</b>		<b>Regulations: LSA Code I/1.2.2.2; MSC.81(70) 1/2.1</b>
<b>Test Procedure</b>	<b>Acceptance Criteria</b>	<b>Significant Test Data</b>
<p>A lifejacket should be subjected to a temperature cycling test of surrounding temperatures of -30°C and +65°C. These alternating cycles need not follow immediately after each other and the following procedure, repeated for a total of 10 cycles, is acceptable:</p> <ol style="list-style-type: none"> <li>1. an 8 h exposure at a minimum temperature of +65°C to be completed in one day; and</li> <li>2. the specimens removed from the warm chamber that same day and left exposed under ordinary room conditions at a temperature of 20°C ± 3°C until the next day;</li> <li>3. an 8 h exposure at a maximum temperature of -30°C to be completed the next day; and</li> <li>4. the specimen removed from the cold chamber that same day and left exposed under ordinary room conditions at a temperature of 20°C ± 3°C until the next day.</li> </ol> <p>The lifejacket should then be externally examined.</p>	<p>The lifejacket material should show no sign of damage such as shrinking, cracking, swelling, dissolution or changes of mechanical qualities.</p>	<p>(See following page for test data)</p> <p>Passed _____ Failed _____</p> <p>Comments/Observations</p>

2.2.1.5 Temperature cycling test – Test data			Regulations: LSA Code I/1.2.2.2; MSC.81(70) 1/2.1	
	HOT CYCLE		COLD CYCLE	
Cycle 1	Date In: _____ Time In: _____ Temperature: _____ °C	Date Out: _____ Time Out: _____ Duration: _____ hours	Date In: _____ Time In: _____ Temperature: _____ °C	Date Out: _____ Time Out: _____ Duration: _____ hours
Cycle 2	Date In: _____ Time In: _____ Temperature: _____ °C	Date Out: _____ Time Out: _____ Duration: _____ hours	Date In: _____ Time In: _____ Temperature: _____ °C	Date Out: _____ Time Out: _____ Duration: _____ hours
Cycle 3	Date In: _____ Time In: _____ Temperature: _____ °C	Date Out: _____ Time Out: _____ Duration: _____ hours	Date In: _____ Time In: _____ Temperature: _____ °C	Date Out: _____ Time Out: _____ Duration: _____ hours
Cycle 4	Date In: _____ Time In: _____ Temperature: _____ °C	Date Out: _____ Time Out: _____ Duration: _____ hours	Date In: _____ Time In: _____ Temperature: _____ °C	Date Out: _____ Time Out: _____ Duration: _____ hours
Cycle 5	Date In: _____ Time In: _____ Temperature: _____ °C	Date Out: _____ Time Out: _____ Duration: _____ hours	Date In: _____ Time In: _____ Temperature: _____ °C	Date Out: _____ Time Out: _____ Duration: _____ hours
Cycle 6	Date In: _____ Time In: _____ Temperature: _____ °C	Date Out: _____ Time Out: _____ Duration: _____ hours	Date In: _____ Time In: _____ Temperature: _____ °C	Date Out: _____ Time Out: _____ Duration: _____ hours
Cycle 7	Date In: _____ Time In: _____ Temperature: _____ °C	Date Out: _____ Time Out: _____ Duration: _____ hours	Date In: _____ Time In: _____ Temperature: _____ °C	Date Out: _____ Time Out: _____ Duration: _____ hours
Cycle 8	Date In: _____ Time In: _____ Temperature: _____ °C	Date Out: _____ Time Out: _____ Duration: _____ hours	Date In: _____ Time In: _____ Temperature: _____ °C	Date Out: _____ Time Out: _____ Duration: _____ hours
Cycle 9	Date In: _____ Time In: _____ Temperature: _____ °C	Date Out: _____ Time Out: _____ Duration: _____ hours	Date In: _____ Time In: _____ Temperature: _____ °C	Date Out: _____ Time Out: _____ Duration: _____ hours
Cycle 10	Date In: _____ Time In: _____ Temperature: _____ °C	Date Out: _____ Time Out: _____ Duration: _____ hours	Date In: _____ Time In: _____ Temperature: _____ °C	Date Out: _____ Time Out: _____ Duration: _____ hours

<b>Inherently buoyant lifejackets</b>	Manufacturer: _____ Model: _____ Lot/Serial Number: _____	Date: _____ Time: _____ Surveyor: _____ Organization: _____						
<b>2.2.1.6 Buoyancy test</b>		<b>Regulations: LSA Code II/2.2.1.11; MSC.81(70) 1/2.2</b>						
<b>Test Procedure</b>	<b>Acceptance Criteria</b>	<b>Significant Test Data</b>						
<p>The two lifejackets subjected to temperature cycling and the hot and cold inflation test should then be used for the buoyancy test.</p> <p>The buoyancy of the two lifejackets should be measured before and after 24 h complete submersion to just below the surface in fresh water. The test to be repeated as many times as necessary to perform the test once with each compartment in the uninflated condition.</p>	<p>The difference between the initial buoyancy and the final buoyancy should not exceed 5% of the initial buoyancy.</p>	<p>Buoyancy test method: _____</p> <p>Start (time): _____</p> <p>Temperature: _____</p> <p>Finish (time): _____</p> <p>Temperature: _____</p> <table style="width:100%; border: none;"> <tr> <td style="text-align: center;">Buoyancy 1</td> <td style="text-align: center;">Buoyancy 2</td> <td style="text-align: center;">%difference</td> </tr> <tr> <td style="text-align: center;">_____ kg</td> <td style="text-align: center;">_____ kg</td> <td style="text-align: center;">_____ %</td> </tr> </table> <p>Passed _____                      Failed _____</p> <p>Comments/Observations</p>	Buoyancy 1	Buoyancy 2	%difference	_____ kg	_____ kg	_____ %
Buoyancy 1	Buoyancy 2	%difference						
_____ kg	_____ kg	_____ %						

<b>Inherently buoyant lifejackets</b>	Manufacturer: _____ Model: _____ Lot/Serial Number: _____	Date: _____ Time: _____ Surveyor: _____ Organization: _____
<b>2.2.1.7 Fire test</b>		<b>Regulations: LSA Code II/2.2.1.1; MSC.81(70) 1/1.5, 2.3</b>
Test Procedure	Acceptance Criteria	Significant Test Data
<p>A test pan 30 cm x 35 cm x 6 cm should be placed in an essentially draught-free area. Water should be put into the bottom of the test pan to a depth of 1 cm followed by enough petrol to make a minimum total depth of 4 cm. The petrol should then be ignited and allowed to burn freely for 30s. The lifejacket should then be moved through the flames in an upright, forward, free-hanging position, with the bottom of the lifejacket 25 cm above the top edge of the test pan so that the duration of exposure to the flames is 2 s.</p>	<p>The lifejacket should not sustain burning for more than 6s or continue melting after being removed from the flames.</p>	<p>Passed _____ Failed _____</p> <p>Comments/Observations</p>
<b>2.2.1.8 Oil resistance test</b>		<b>Regulations: LSA Code II/1.2.2; MSC.81(70) 1/1.4</b>
Test Procedure	Acceptance Criteria	Significant Test Data
<p>The lifejacket should be immersed horizontally for a period of 24 h under 100 mm head of diesel oil at normal room temperature.</p>	<p>After this test, the lifejacket should show no signs of damage such as shrinking, cracking, swelling, dissolution or change of mechanical qualities.</p>	<p>Passed _____ Failed _____</p> <p>Comments/Observations</p>



<b>Inherently buoyant lifejackets</b>	Manufacturer: _____ Model: _____ Lot/Serial Number: _____	Date: _____ Time: _____ Surveyor: _____ Organization: _____
---------------------------------------	---	---

<b>2.2.1.9 Tests of components other than buoyancy materials (Continued)</b>	<b>Regulations: LSA Code I/1.2.2; MSC.81(70) 1/2.4</b>
--	--

Test Procedure	Acceptance Criteria	Significant Test Data
<p>All the materials, other than buoyancy materials, used in the construction of the lifejacket including the cover, tapes, seams and closures should be tested to establish that they are:</p> <p>.1 rot-proof,</p> <p>.2 colour-fast and</p> <p>.3 resistant to deterioration from exposure to sunlight</p> <p>and that they are not unduly affected by</p> <p>.4 seawater,</p> <p>.5 oil or</p> <p>.6 fungal attack</p>	<p>The results should be acceptable to the International Organization for Standardization, in particular publication ISO 12402-7:2006 Personal Flotation Devices – Part 7: Materials and Components – Safety Requirements and Test Methods (to be published).</p>	<p>Tests: (Specify): _____</p> <p style="text-align: right;"><u>Cover:</u>   <u>Tapes:</u>   <u>Seams:</u>   <u>Additional equipment:</u></p> <p>Tensile strength as received (new material) (N/25 mm width) : _____</p> <p>Tear strength as received (N) : _____ <u>N/A</u>   <u>N/A</u> _____</p> <p>.1 Tensile strength after microbial exposure Method: _____ Duration: _____  (N/25 mm width) _____ (% retained strength) _____</p> <p>.2 Resistance to rubbing, wet and dry – (ISO 105-X12:2001 &amp; 105-E02:1994) Cycles: _____ : _____</p> <p>.3 Tensile strength after weathering Weathering Method: _____ Duration: _____ (N/25 mm width) _____ (% retained strength) _____</p> <p>Acceptable:    1) <input type="checkbox"/> Yes <input type="checkbox"/> No 2) <input type="checkbox"/> Yes <input type="checkbox"/> No 3) <input type="checkbox"/> Yes <input type="checkbox"/> No</p> <p>.4 Tensile strength after exposure to sea water. Method: _____ Duration: _____ (N/25 mm width) _____ (% retained strength) _____</p>

		<p>.5 Tensile strength after exposure to oil Type of oil: _____ Duration: _____ (N/25 mm width) _____ (% retained strength) _____</p> <p>.6 Tensile strength after fungal attach. Type of oil: _____ Duration: _____ (N/25 mm width) _____ (% retained strength) _____</p> <p>Acceptable: 4) <input type="checkbox"/> Yes <input type="checkbox"/> No 5) <input type="checkbox"/> Yes <input type="checkbox"/> No 6) <input type="checkbox"/> Yes <input type="checkbox"/> No</p>
--	--	---

<b>Inherently buoyant lifejackets</b>	Manufacturer: _____ Model: _____ Lot/Serial Number: _____	Date: _____ Time: _____ Surveyor: _____ Organization: _____
---------------------------------------	---	---

<b>2.2.1.10 Strength tests - Body or lifting loop strength tests</b>	<b>Regulations: LSA Code I/1.2.2; MSC.81(70) 1/2.5.1</b>
--	--

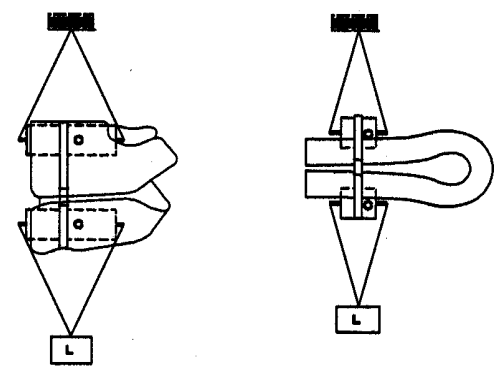
Test Procedure	Acceptance Criteria	Significant Test Data																											
<p>The lifejacket should be immersed in water for a period of 2 min. It should then be removed from the water and closed in the same manner as when it is worn by a person. A force of not less than 3,200 N (2,400 N in the case of a child or infant-size lifejacket) should be applied for 30 min to the part of the lifejacket that secures it to the body of the wearer (see figure 1) and separately to the lifting loop of the lifejacket.</p> <div style="text-align: center;">  <p style="font-size: small;">Vest-type lifejacket      Yoke or over-the-head type lifejacket</p> </div> <p>Figure 1 Body strength test arrangement for lifejackets</p> <p>C– Cylinder 125mm diameter for adult sizes 50mm diameter for Infant and child size L– Test load</p>	<p>The lifejacket should not be damaged as a result of this test. The test should be repeated for each encircling closure.</p>	<table style="width:100%; border-collapse: collapse;"> <tr> <td></td> <td style="text-align: center;">Body strap</td> <td style="text-align: center;">Lifting loop</td> </tr> <tr> <td>Force applied:</td> <td style="text-align: center;">_____</td> <td style="text-align: center;">_____</td> </tr> <tr> <td>Time:</td> <td style="text-align: center;">_____</td> <td style="text-align: center;">_____</td> </tr> <tr> <td>Slippage:</td> <td style="text-align: center;">_____</td> <td style="text-align: center;">_____</td> </tr> <tr> <td colspan="3">Closure(s) tested: _____</td> </tr> <tr> <td colspan="3">Illustration of lifejacket lifting loop test arrangement if tested:</td> </tr> <tr> <td colspan="3">Test results</td> </tr> <tr> <td>Closure system:</td> <td style="text-align: center;">Passed _____</td> <td style="text-align: center;">Failed _____</td> </tr> <tr> <td>Lifting loop:</td> <td style="text-align: center;">Passed _____</td> <td style="text-align: center;">Failed _____</td> </tr> </table>		Body strap	Lifting loop	Force applied:	_____	_____	Time:	_____	_____	Slippage:	_____	_____	Closure(s) tested: _____			Illustration of lifejacket lifting loop test arrangement if tested:			Test results			Closure system:	Passed _____	Failed _____	Lifting loop:	Passed _____	Failed _____
	Body strap	Lifting loop																											
Force applied:	_____	_____																											
Time:	_____	_____																											
Slippage:	_____	_____																											
Closure(s) tested: _____																													
Illustration of lifejacket lifting loop test arrangement if tested:																													
Test results																													
Closure system:	Passed _____	Failed _____																											
Lifting loop:	Passed _____	Failed _____																											

<b>Inherently buoyant lifejackets</b>	Manufacturer: _____ Model: _____ Lot/Serial Number: _____	Date: _____ Time: _____ Surveyor: _____ Organization: _____
---------------------------------------	---	---

<b>2.2.1.11 Strength tests - Shoulder lift test</b>	<b>Regulations: LSA Code I/1.2.2; MSC.81(70) 1/2.5.2</b>
---	--

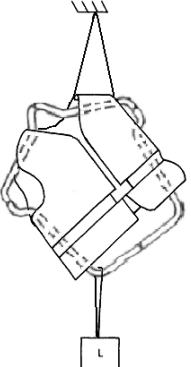
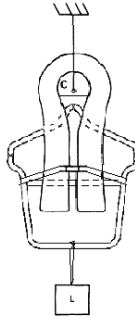
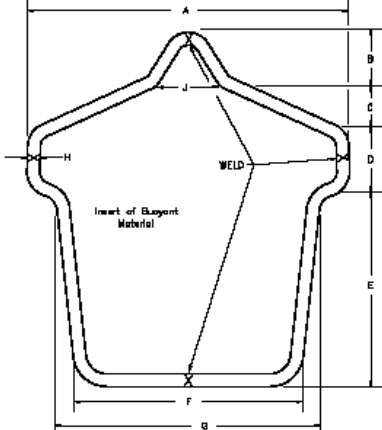
Test Procedure	Acceptance Criteria	Significant Test Data																																								
<p>The lifejacket should be immersed in water for a period of 2 min. It should then be removed from the water and closed on a form as shown in figure 2 in the same manner as when it is worn by a person. A force of not less than 900 N (700 N in the case of a child or infant-size lifejacket) should be applied for 30 min across the form and the shoulder section of the lifejacket (see figure 3).</p> <div style="display: flex; justify-content: space-around; align-items: center;">   </div> <p style="text-align: center;">Vest-type lifejacket      Yoke or over-the-head-type lifejacket</p> <p>Figure 3- Shoulder lift test arrangement for lifejackets</p> <p>C- Cylinder; 125mm diameter for adult sizes 50mm diameter for infant and child sizes L- Test load</p>	<p>The lifejacket should not be damaged as a result of this test. The lifejacket should remain secured on the form during this test.</p> <div style="text-align: center;">  </div> <table border="1" style="margin: 10px auto; border-collapse: collapse; text-align: center;"> <thead> <tr> <th>Size</th> <th>A</th> <th>B</th> <th>C</th> <th>D</th> <th>E</th> <th>F</th> <th>G</th> <th>H</th> <th>J</th> </tr> </thead> <tbody> <tr> <td>Adult</td> <td>610</td> <td>114</td> <td>76,2</td> <td>127</td> <td>381</td> <td>432</td> <td>508</td> <td>25,4</td> <td>178</td> </tr> <tr> <td>Child</td> <td>508</td> <td>102</td> <td>76,2</td> <td>102</td> <td>279</td> <td>330</td> <td>406</td> <td>22,2</td> <td>152</td> </tr> <tr> <td>Infant</td> <td>305</td> <td>63,5</td> <td>38,1</td> <td>63,5</td> <td>191</td> <td>203</td> <td>241</td> <td>19,1</td> <td>76,2</td> </tr> </tbody> </table> <p style="text-align: center;">Dimensions in mm</p> <p style="text-align: center;">Figure 2 – Test form for shoulder lift test for lifejackets</p>	Size	A	B	C	D	E	F	G	H	J	Adult	610	114	76,2	127	381	432	508	25,4	178	Child	508	102	76,2	102	279	330	406	22,2	152	Infant	305	63,5	38,1	63,5	191	203	241	19,1	76,2	<p>Force applied: _____</p> <p>Shoulder tested: _____</p> <p>Test result:</p> <p>Passed _____ Failed _____</p> <p>Comments/Observations</p>
Size	A	B	C	D	E	F	G	H	J																																	
Adult	610	114	76,2	127	381	432	508	25,4	178																																	
Child	508	102	76,2	102	279	330	406	22,2	152																																	
Infant	305	63,5	38,1	63,5	191	203	241	19,1	76,2																																	

<b>Inherently buoyant lifejackets</b>	Manufacturer: _____ Model: _____ Lot/Serial Number: _____	Date: _____ Time: _____ Surveyor: _____ Organization: _____																																																																																																								
<b>2.2.1.12 Tests for lifejacket buoyancy material – Stability under temperature cycling</b>		<b>Regulations: LSA Code I/1.2.2; MSC.81(70) 1/2.6 (2.6.1-2.6.4)</b>																																																																																																								
Test Procedure	Acceptance Criteria	Significant Test Data																																																																																																								
<p>The following tests should be carried out on eight specimens of each lifejacket buoyancy material. A further four specimens of each lifejacket-buoyancy material should be prepared for the tensile strength test in 2.2.1.14.</p> <p>The specimens should be at least 300mm square and be of the same thickness as used in the lifejacket.</p> <p>The specimen should be labelled and the dimension should be recorded prior to the test. In the case of kapok, the entire lifejacket should be subjected to the test. The dimensions should be recorded at the beginning and end of these tests. Where multiple layers of materials are used to achieve the total thickness desired for the lifejacket, the specimens should be of the thinnest material used.</p> <p>← Six specimens should be subjected to temperature cycling as prescribed in 2.2.1.5.</p> <p>↑ The dimensions of the specimens (except kapok) should be recorded at the end of the last cycle. The specimens should be carefully examined.</p>	<p>The specimens should not show any sign of internal and external change of structure or of mechanical qualities.</p>	<table style="width:100%; border-collapse: collapse;"> <thead> <tr> <th style="text-align: left;">Dimensions prior to test</th> <th style="text-align: center;">Length</th> <th style="text-align: center;">Width</th> <th style="text-align: center;">Height</th> </tr> </thead> <tbody> <tr><td>Specimen No. 1</td><td style="text-align: center;">_____</td><td style="text-align: center;">_____</td><td style="text-align: center;">_____</td></tr> <tr><td>Specimen No. 2</td><td style="text-align: center;">_____</td><td style="text-align: center;">_____</td><td style="text-align: center;">_____</td></tr> <tr><td>Specimen No. 3</td><td style="text-align: center;">_____</td><td style="text-align: center;">_____</td><td style="text-align: center;">_____</td></tr> <tr><td>Specimen No. 4</td><td style="text-align: center;">_____</td><td style="text-align: center;">_____</td><td style="text-align: center;">_____</td></tr> <tr><td>Specimen No. 5</td><td style="text-align: center;">_____</td><td style="text-align: center;">_____</td><td style="text-align: center;">_____</td></tr> <tr><td>Specimen No. 6</td><td style="text-align: center;">_____</td><td style="text-align: center;">_____</td><td style="text-align: center;">_____</td></tr> <tr><td colspan="4"> </td></tr> <tr> <th style="text-align: left;">Dimensions after test</th> <th style="text-align: center;">Length</th> <th style="text-align: center;">Width</th> <th style="text-align: center;">Height</th> </tr> <tr><td>Specimen No. 1</td><td style="text-align: center;">_____</td><td style="text-align: center;">_____</td><td style="text-align: center;">_____</td></tr> <tr><td>Specimen No. 2</td><td style="text-align: center;">_____</td><td style="text-align: center;">_____</td><td style="text-align: center;">_____</td></tr> <tr><td>Specimen No. 3</td><td style="text-align: center;">_____</td><td style="text-align: center;">_____</td><td style="text-align: center;">_____</td></tr> <tr><td>Specimen No. 4</td><td style="text-align: center;">_____</td><td style="text-align: center;">_____</td><td style="text-align: center;">_____</td></tr> <tr><td>Specimen No. 5</td><td style="text-align: center;">_____</td><td style="text-align: center;">_____</td><td style="text-align: center;">_____</td></tr> <tr><td>Specimen No. 6</td><td style="text-align: center;">_____</td><td style="text-align: center;">_____</td><td style="text-align: center;">_____</td></tr> <tr><td colspan="4"> </td></tr> <tr> <td style="text-align: right;">Passed</td> <td style="text-align: center;">_____</td> <td style="text-align: center;">_____</td> <td style="text-align: right;">Failed</td> </tr> <tr><td>Specimen No.1</td><td style="text-align: center;">_____</td><td style="text-align: center;">_____</td><td style="text-align: center;">_____</td></tr> <tr><td>Specimen No.2</td><td style="text-align: center;">_____</td><td style="text-align: center;">_____</td><td style="text-align: center;">_____</td></tr> <tr><td>Specimen No.3</td><td style="text-align: center;">_____</td><td style="text-align: center;">_____</td><td style="text-align: center;">_____</td></tr> <tr><td>Specimen No.4</td><td style="text-align: center;">_____</td><td style="text-align: center;">_____</td><td style="text-align: center;">_____</td></tr> <tr><td>Specimen No.5</td><td style="text-align: center;">_____</td><td style="text-align: center;">_____</td><td style="text-align: center;">_____</td></tr> <tr><td>Specimen No.6</td><td style="text-align: center;">_____</td><td style="text-align: center;">_____</td><td style="text-align: center;">_____</td></tr> <tr> <td colspan="4">Mechanical qualities evaluated and procedure used:</td> </tr> <tr><td colspan="4">_____</td></tr> <tr><td colspan="4">_____</td></tr> </tbody> </table>	Dimensions prior to test	Length	Width	Height	Specimen No. 1	_____	_____	_____	Specimen No. 2	_____	_____	_____	Specimen No. 3	_____	_____	_____	Specimen No. 4	_____	_____	_____	Specimen No. 5	_____	_____	_____	Specimen No. 6	_____	_____	_____					Dimensions after test	Length	Width	Height	Specimen No. 1	_____	_____	_____	Specimen No. 2	_____	_____	_____	Specimen No. 3	_____	_____	_____	Specimen No. 4	_____	_____	_____	Specimen No. 5	_____	_____	_____	Specimen No. 6	_____	_____	_____					Passed	_____	_____	Failed	Specimen No.1	_____	_____	_____	Specimen No.2	_____	_____	_____	Specimen No.3	_____	_____	_____	Specimen No.4	_____	_____	_____	Specimen No.5	_____	_____	_____	Specimen No.6	_____	_____	_____	Mechanical qualities evaluated and procedure used:				_____				_____			
Dimensions prior to test	Length	Width	Height																																																																																																							
Specimen No. 1	_____	_____	_____																																																																																																							
Specimen No. 2	_____	_____	_____																																																																																																							
Specimen No. 3	_____	_____	_____																																																																																																							
Specimen No. 4	_____	_____	_____																																																																																																							
Specimen No. 5	_____	_____	_____																																																																																																							
Specimen No. 6	_____	_____	_____																																																																																																							
Dimensions after test	Length	Width	Height																																																																																																							
Specimen No. 1	_____	_____	_____																																																																																																							
Specimen No. 2	_____	_____	_____																																																																																																							
Specimen No. 3	_____	_____	_____																																																																																																							
Specimen No. 4	_____	_____	_____																																																																																																							
Specimen No. 5	_____	_____	_____																																																																																																							
Specimen No. 6	_____	_____	_____																																																																																																							
Passed	_____	_____	Failed																																																																																																							
Specimen No.1	_____	_____	_____																																																																																																							
Specimen No.2	_____	_____	_____																																																																																																							
Specimen No.3	_____	_____	_____																																																																																																							
Specimen No.4	_____	_____	_____																																																																																																							
Specimen No.5	_____	_____	_____																																																																																																							
Specimen No.6	_____	_____	_____																																																																																																							
Mechanical qualities evaluated and procedure used:																																																																																																										
_____																																																																																																										
_____																																																																																																										

2.2.1.12 Tests for lifejacket buoyancy material – Stability under temperature cycling		Regulations: LSA Code I/1.2.2; MSC.81(70) 1/2.6 (2.6.1-2.6.4)
Test Procedure	Acceptance Criteria	Significant Test Data
		↑ Passed _____ Failed _____ → Passed _____ Failed _____ ↓ Passed _____ Failed _____  Comments/Observations (See following page for test data)
→ Two of the specimens should be cut open and should be carefully examined.  ↓ Four of the specimens should be used for compression and water absorption tests, two of which should be so tested after they have also been subjected to the diesel oil test as prescribed in 2.2.1.8.	The specimens should not show any sign of internal change of structure.	<input type="checkbox"/> Passed _____ Failed _____ <input type="checkbox"/> Passed _____ Failed _____ <input type="checkbox"/> Passed _____ Failed _____  Comments/Observations

<b>Inherently buoyant lifejackets</b>	Manufacturer: _____		Date: _____ Time: _____	
	Model: _____		Surveyor: _____	
	Lot/Serial Number: _____		Organization: _____	
<b>2.2.1.12 Temperature cycling test – Test data</b>			<b>Regulations: LSA Code I/1.2.2; MSC.81(70) 1/2.1</b>	
	<b>HOT CYCLE</b>		<b>COLD CYCLE</b>	
Cycle 1	Date In: _____ Time In: _____ Temperature: _____ °C	Date Out: _____ Time Out: _____ Duration: _____ hours	Date In: _____ Time In: _____ Temperature: _____ °C	Date Out: _____ Time Out: _____ Duration: _____ hours
Cycle 2	Date In: _____ Time In: _____ Temperature: _____ °C	Date Out: _____ Time Out: _____ Duration: _____ hours	Date In: _____ Time In: _____ Temperature: _____ °C	Date Out: _____ Time Out: _____ Duration: _____ hours
Cycle 3	Date In: _____ Time In: _____ Temperature: _____ °C	Date Out: _____ Time Out: _____ Duration: _____ hours	Date In: _____ Time In: _____ Temperature: _____ °C	Date Out: _____ Time Out: _____ Duration: _____ hours
Cycle 4	Date In: _____ Time In: _____ Temperature: _____ °C	Date Out: _____ Time Out: _____ Duration: _____ hours	Date In: _____ Time In: _____ Temperature: _____ °C	Date Out: _____ Time Out: _____ Duration: _____ hours
Cycle 5	Date In: _____ Time In: _____ Temperature: _____ °C	Date Out: _____ Time Out: _____ Duration: _____ hours	Date In: _____ Time In: _____ Temperature: _____ °C	Date Out: _____ Time Out: _____ Duration: _____ hours
Cycle 6	Date In: _____ Time In: _____ Temperature: _____ °C	Date Out: _____ Time Out: _____ Duration: _____ hours	Date In: _____ Time In: _____ Temperature: _____ °C	Date Out: _____ Time Out: _____ Duration: _____ hours
Cycle 7	Date In: _____ Time In: _____ Temperature: _____ °C	Date Out: _____ Time Out: _____ Duration: _____ hours	Date In: _____ Time In: _____ Temperature: _____ °C	Date Out: _____ Time Out: _____ Duration: _____ hours
Cycle 8	Date In: _____ Time In: _____ Temperature: _____ °C	Date Out: _____ Time Out: _____ Duration: _____ hours	Date In: _____ Time In: _____ Temperature: _____ °C	Date Out: _____ Time Out: _____ Duration: _____ hours
Cycle 9	Date In: _____ Time In: _____ Temperature: _____ °C	Date Out: _____ Time Out: _____ Duration: _____ hours	Date In: _____ Time In: _____ Temperature: _____ °C	Date Out: _____ Time Out: _____ Duration: _____ hours
Cycle 10	Date In: _____ Time In: _____ Temperature: _____ °C	Date Out: _____ Time Out: _____ Duration: _____ hours	Date In: _____ Time In: _____ Temperature: _____ °C	Date Out: _____ Time Out: _____ Duration: _____ hours

<b>Inherently buoyant lifejackets</b>	Manufacturer: _____ Model: _____ Lot/Serial Number: _____	Date: _____ Time: _____ Surveyor: _____ Organization: _____
<b>2.2.1.13 Tests for lifejacket buoyancy material – Compression and water absorption test</b>		<b>Regulations: LSA Code I/1.2.2; MSC.81(70) 1/2.6 (2.6.5-2.6.7)</b>
Test Procedure	Acceptance Criteria	Significant Test Data
<p>The following tests should be carried out on six specimens of each type of lifejacket buoyancy material. The tests should be carried out in fresh water and the specimens should be immersed for a period of seven days under a 1.25 m head of water.</p> <p>The tests should be carried out:</p> <p>.1 on two specimens as supplied;</p> <p>.2 on two specimens which have been subjected to the temperature cycling as prescribed in 2.2.1.12; and</p> <p>.3 on two specimens which have been subjected to the temperature cycling as prescribed in 2.2.1.12 followed by the diesel oil test as prescribed in 2.2.1.8.</p>	<p>The specimens should show no sign of damage such as shrinking, cracking, swelling, dissolution or change of mechanical qualities.</p> <p>The results should state the buoyant force in N, which each specimen exerts when submerged in water after 1 and 7 days immersion.</p> <p>The reduction of buoyancy should not exceed 10% for specimens which have been exposed to the diesel oil conditioning and should not exceed 5% for all specimens.</p>	<p><u>Test results:</u> (As supplied specimens)</p> <p style="text-align: right;">After 1 day    After 7 days    %diff.</p> <p><u>Test results:</u> (Specimens subjected to temperature cycling)</p> <p>Specimen No. 3 _____ N _____ N % _____</p> <p>Passed _____ Failed _____</p> <p>Specimen No. 4 _____ N _____ N % _____</p> <p>Passed _____ Failed _____</p> <p><u>Test results:</u> (Specimens subject to temperature cycling and oil exposure)</p> <p>Specimen No. 5 _____ N _____ N % _____</p> <p>Passed _____ Failed _____</p> <p>Specimen No. 6 _____ N _____ N % _____</p> <p>Passed _____ Failed _____</p> <p>Comments/Observations</p>



<b>Inherently buoyant lifejackets</b>	Manufacturer: _____ Model: _____ Lot/Serial Number: _____	Date: _____ Time: _____ Surveyor: _____ Organization: _____
<b>2.2.1.14 Tests for lifejacket buoyancy material – Tensile strength test</b>		<b>Regulations: LSA Code I/1.2.2; MSC.81(70) 1/ 2.6.8</b>
Test Procedure	Acceptance Criteria	Significant Test Data
<p>Four specimens of each lifejacket-buoyancy material should be tested.</p> <p>The tensile strength at break of the material should be measured before and after the combined exposure described in 2.6.6.3. of MSC.81(70).</p>	<p>When tested according to an international standard, ISO 12402-7:2006 Personal flotation devices – Part 7: Materials and components – Safety requirements and test methods, acceptable to the Organization, the materials should have a minimum tensile strength of 140 kPa before exposure, which should not be reduced by more than 25% following the combined exposures.</p> <p>In the case of kapok, the protective cover should have a minimum breaking strength of 13 kPa before exposure, which should not be reduced by more than 25% following the combined exposures.</p>	<p>Test Results: (Specimens before exposure)</p> <p>Min. Tensile Strength =140kPa (?)          Specimen No 1 Yes _____ No _____          Passed _____ Failed _____          Specimen No 2 Yes _____ No _____          Passed _____ Failed _____</p> <p>Test Results: (Specimens after combined exposure)</p> <p>Reduction in Tensile Strength <math>\leq</math>25%          Specimen No 1 Yes _____ No _____          Passed _____ Failed _____          Specimen No 2 Yes _____ No _____          Passed _____ Failed _____</p> <p>Test Results: (Protective cover for kapok before exposure)</p> <p>Min. Breaking Strength =13 kPa (?)          Specimen No 1 Yes _____ No _____          Passed _____ Failed _____          Specimen No 2 Yes _____ No _____          Passed _____ Failed _____</p> <p>Test Results: (Protective cover for kapok after combined exposure)</p> <p>Reduction in Breaking Strength <math>\leq</math> 25 %          Specimen No 1 Yes _____ No _____          Passed _____ Failed _____          Specimen No 2 Yes _____ No _____          Passed _____ Failed _____</p> <p>Comments/Observations</p>

<b>Inherently buoyant lifejackets</b>	Manufacturer: _____ Model: _____ Lot/Serial Number: _____	Date: _____ Time: _____ Surveyor: _____ Organization: _____
<b>2.2.1.15 Donning Test</b>		<b>Regulations: LSA Code II/2.2.1.5; MSC.81(70) 1/2.7.1 to 2.7.4.3</b>
Test Procedure	Acceptance Criteria	Significant Test Data
<p>To minimize the risk of incorrect donning by uninitiated persons, often in adverse conditions, lifejackets should be examined for the following features and tested as follows:</p> <p>Test subjects</p> <p>The test should be carried out with at least 12 able-bodied persons who are completely unfamiliar with the lifejacket and selected according to the heights and weights in table 2.1 and the following:</p> <ul style="list-style-type: none"> <li>.1 small test subjects need not be adults;</li> <li>.2 at least 1/3, but not more than 1/2 of test subjects should be females, including at least 1 per height category but excluding the tallest height;</li> <li>.3 at least one male should be from the lowest and highest weight group and one female should be from the lowest weight group and one female should be more than 80 kg and 1.8 m;</li> <li>.4 at least one subject should be selected from each cell containing a "1"; and</li> <li>.5 enough additional subjects should be selected from cells containing a "X" to total the required number of test subjects, with no more than one subject per cell. A uniform distribution across weight ranges should be maintained.</li> </ul>	<p>Fastenings necessary for proper performance should be few and simple and provide quick and positive closure that does not require tying of knots.</p> <p>Adult lifejackets should readily fit various sizes of adults, both lightly and heavily clad. All lifejackets should be capable of being worn inside-out, or clearly in only one way.</p>	



2.2.1.15 Donning Test (Continued)	Regulations: LSA Code II/2.2.1.5; MSC.81(70) 1/2.7.1 to 2.7.4.3	
Test Procedure	Acceptance Criteria	Significant Test Data
<p>Clothing</p> <p>Each test subject should be tested wearing the clothing specified for the test and appropriate to their size, as follows:</p> <p>.1 <i>Normal clothing</i> means normal indoor clothing, which would not normally interfere with the donning of a lifejacket;</p> <p>.2 <i>Heavy-weather clothing</i> means the attire appropriate for a hostile environment, including a hooded arctic parka and warm cotton gloves.</p> <p>Each test should be timed from when the order is given until the test subject declares that donning is complete.</p> <p><i>Test without instruction</i></p> <p>The test subjects may be tested individually or as a group. Wearing normal clothing, the first attempt should be with no assistance, guidance or prior demonstration. The lifejacket, with closures in the stored condition, should be placed on the floor, face up, in front of the test subject. The instruction provided should be identical for each subject and should be equivalent to the following: "PLEASE DON THIS LIFEJACKET AS QUICKLY AS POSSIBLE AND ADJUST IT TO A SNUG FIT SO YOU CAN ABANDON SHIP."</p>	<p>For assessment purposes donning is considered complete when the subject has donned and securely adjusted all methods of securing the lifejacket to the extent needed to meet the in -water performance requirements, including inflation, if needed.</p> <p>The lifejacket should be capable of being donned by at least 75 % of the subjects, and within 1 minute.</p> <p>If a subject dons the lifejacket substantially correctly but fails to secure and/or adjust all closures, the jump test in 2.8.8 of MSC.81(70) and in-water performance tests in 2.8.5 of MSC.81(70) and 2.8.6 of MSC.81(70) should be performed with the lifejacket as donned to establish whether the performance is acceptable and the donning is successful.</p>	<p>See following page for test data</p> <p>Total number of subjects: _____</p> <p># of subjects successful: _____</p> <p># of subjects successful: _____</p> <p>Pass / Fail</p>

2.2.1.15 Donning Test (Continued)		Regulations: LSA Code II/2.2.1.5; MSC.81(70) 1/2.7.1 to 2.7.4.3
Test Procedure	Acceptance Criteria	Significant Test Data
<p><i>Test after instruction</i></p> <p>For each subject whose first attempt exceeds 1 min or is incomplete, after demonstration or instruction to familiarize the subject with the donning procedure, the test subject should then don the lifejacket without assistance while wearing normal clothing, using the same instruction and timing method as above.</p>	<p>Each subject should correctly don the lifejacket within a period of 1 min.</p>	<p>Pass / Fail</p>
<p><i>Heavy-weather clothing test</i></p> <p>Each subject should then don the lifejacket without assistance while wearing heavy-weather clothing, using the same instruction and timing method as above.</p>	<p>Each subject should don the lifejacket correctly within a period of 1 min.</p>	<p>Pass / Fail</p>

<b>Inherently buoyant lifejackets</b>	Manufacturer: _____ Model: _____ Lot/Serial Number: _____	Date: _____ Time: _____ Surveyor: _____ Organization: _____				
<b>2.2.1.15 Donning Test – Test Data</b>		<b>Regulations: LSA Code II/2.2.1.5; MSC.81(70) 1/2.7.1 to 2.7.4.3</b>				
	Test without instruction	Test after instruction				
		Heavy weather clothing test				
Subject	Donning time (sec)	All closures secured? (Y/N)	Jump test (P/F)	In-water test (P/F)	Donning Time (sec)	Donning time (sec)
1						
2						
3						
4						
5						
6						
7						
8						
9						
10						
11						
12						
Comments/Observations:						

<b>Inherently buoyant lifejackets</b>	Manufacturer: _____ Model: _____ Lot/Serial Number: _____	Date: _____ Time: _____ Surveyor: _____ Organization: _____																																																							
<b>2.2.1.16 Water performance tests- Preparation for water performance tests</b>		<b>Regulations: LSA Code II/2.2.1.2.5 &amp; 2.2.1.3 - 2.2.1.4; MSC.81(70) 1/2.8 to 2.8.4, Annex 1, MSC.1/Circ.1470</b>																																																							
<b>Test Procedure</b>	<b>Acceptance Criteria</b>	<b>Significant Test Data</b>																																																							
<p>This portion of the test is intended to determine the ability of the lifejacket to assist a helpless person or one in an exhausted or unconscious state and to show that the lifejacket does not unduly restrict movement.</p> <p>The in-water performance of a lifejacket is evaluated by comparison to the performance of a suitable size standard reference lifejacket, i.e. Reference Test Device (RTD) as specified in appendices 1 to 3.</p> <p>All tests should be carried out in fresh water under still conditions. Each test for a candidate lifejacket and the relevant RTD should be conducted on the same day.</p> <p>These tests should be carried out with at least 12 persons as mentioned in paragraph 2.2.1.15. Only good swimmers should be used, since the ability to relax in the water is rarely otherwise obtained.</p> <p>The test subjects should wear only swimming costumes.</p> <p>Each test subject should be made familiar with each of the tests in 2.2.1.17 and 2.2.1.18, particularly the requirements regarding relaxing and exhaling in the face-down position.</p> <p>The test subjects should don the lifejacket, unassisted, using only the instructions provided by the manufacturer. Prior to taking measurements, the proper fit, donning, and fastening of the RTD on the subject should be checked and corrected as necessary.</p>	<p>The RTD should be constructed and calibrated according to MSC.81(70), annex 1, and validated according to MSC.1/Circ.1470.</p>	<p>RTD Constructed by: _____ date: _____</p> <p>Validated by: _____ date: _____</p> <p>Calibrated by: _____ date: _____</p> <p>Test subjects same as in 2.2.1.15? If not, describe test subjects:</p> <table border="1" style="width:100%; border-collapse: collapse; text-align:center;"> <thead> <tr> <th>Subj</th> <th>SEX (M/F)</th> <th>HEIGHT (m)</th> <th>WEIGHT (kg)</th> <th>Good Swimmer? (Yes/No)</th> </tr> </thead> <tbody> <tr><td>1</td><td></td><td></td><td></td><td></td></tr> <tr><td>2</td><td></td><td></td><td></td><td></td></tr> <tr><td>3</td><td></td><td></td><td></td><td></td></tr> <tr><td>4</td><td></td><td></td><td></td><td></td></tr> <tr><td>5</td><td></td><td></td><td></td><td></td></tr> <tr><td>6</td><td></td><td></td><td></td><td></td></tr> <tr><td>7</td><td></td><td></td><td></td><td></td></tr> <tr><td>8</td><td></td><td></td><td></td><td></td></tr> <tr><td>9</td><td></td><td></td><td></td><td></td></tr> <tr><td>10</td><td></td><td></td><td></td><td></td></tr> </tbody> </table>	Subj	SEX (M/F)	HEIGHT (m)	WEIGHT (kg)	Good Swimmer? (Yes/No)	1					2					3					4					5					6					7					8					9					10				
Subj	SEX (M/F)	HEIGHT (m)	WEIGHT (kg)	Good Swimmer? (Yes/No)																																																					
1																																																									
2																																																									
3																																																									
4																																																									
5																																																									
6																																																									
7																																																									
8																																																									
9																																																									
10																																																									

<b>2.2.1.16 Water performance tests- Preparation for water performance tests</b>		<b>Regulations: LSA Code II/2.2.1.2.5 &amp; 2.2.1.3 - 2.2.1.4; MSC.81(70) 1/2.8 to 2.8.4, Annex 1, MSC.1/Circ.1470</b>			
Test Procedure	Acceptance Criteria	Significant Test Data			
After entering the water, care should be taken to ensure that there is no significant amount of air unintentionally trapped in the lifejacket or swimming costume.		11			
		12			



<b>Inherently buoyant lifejackets</b>	Manufacturer: _____ Model: _____ Lot/Serial Number: _____	Date: _____ Time: _____ Surveyor: _____ Organization: _____
---------------------------------------	---	---

**2.2.1.17 Water performance tests – Righting test** **Regulations: LSA Code II/ 2.2.1.6.2; MSC.81(70)1/ 2.8.5**

Test Procedure	Acceptance Criteria	Significant Test Data															
<p>Each test subject should assume a prone, face down position in the water, but with the head lifted up so the mouth is out of the water. The subject's feet should be supported, shoulder width apart, with the heels just below the surface of the water.</p> <p>After assuming a starting position with the legs straight and arms along the sides, the subject should then be instructed in the following sequence to allow the body to gradually and completely relax into a natural floating posture: allow the arms and shoulders to relax; allow the legs to relax; and then the spine and neck, letting the head fall into the water while breathing out normally.</p> <p>During the relaxation phase, the subject should be maintained in a stable face down position.</p> <p>Immediately after the subject has relaxed, with the face in the water, simulating a state of utter exhaustion, the subject's feet should be released.</p>	<p>The period of time until the mouth of the test subject comes clear of the water should be recorded to the nearest 1/10 of a second, starting from when the subject's feet are released.</p> <p>The test should be conducted a total of six times, and the highest and lowest times discarded. The test should then be conducted a total of six times in the RTD and the highest and lowest times discarded.</p> <p>Turning time: the average turn time for all subjects in the candidate lifejacket should not exceed the average time in the RTD plus 1 s.</p> <p>The number of "no-turns", if any, should not exceed the number in the RTD.</p>	Subj	CANDIDATE DEVICE TIME (sec) TRIAL							REFERENCE VEST TIME (sec) TRIAL							
			#1	#2	#3	#4	#5	#6	AVG *	#1	#2	#3	#4	#5	#6	AVG *	
				1													
				2													
				3													
				4													
				5													
				6													
				7													
				8													
				9													
				10													
				11													
				12													
		<b>Average candidate turn time (sec):</b>							<b>Average RTD turn time (sec):</b>								
<b># of candidate no turns (NT):</b>							<b># of RTD no turns (NT):</b>										
<p>(* Delete highest and lowest value)            Average candidate turn time ≤ Average RTD turn time RTD +1s    Passed _____    Failed _____            # of candidate no turns (NT) : ≤ # of RTD no turns (NT) :                      Passed _____    Failed _____</p>																	
Comments/Observations:																	

<b>Inherently buoyant lifejackets</b>	Manufacturer: _____ Model: _____ Lot/Serial Number: _____	Date: _____ Time: _____ Surveyor: _____ Organization: _____						
<b>2.2.1.18 Water performance tests-Static balance measurements</b>		<b>Regulations: LSA Code II/ 2.2.1.4; MSC.81(70) 1/ 2.8.6 and 2.8.7</b>						
Test Procedure	Acceptance Criteria	Significant Test Data						
At the conclusion of the righting tests, without making any adjustments in body or lifejacket position, the following measurements should be made with the subject floating in the relaxed face-up position of static balance resulting from the preceding tests.	Freeboard (mm)	Faceplane (deg)	Torso angle (deg)	Light				
	CLJ	RTD	CLJ	RTD	CLJ	RTD	Visible?	
	1							
	2							
	3							
	4							
	5							
	6							
	7							
	8							
	9							
	10							
	11							
	12							
Avg							XXXXX	
CLJ – Candidate Lifejacket RTD – Reference Test Device								

2.2.1.18 Water performance tests-Static balance measurements		Regulations: LSA Code II/ 2.2.1.4; MSC.81(70) 1/ 2.8.6 and 2.8.7	
Test Procedure	Acceptance Criteria	Significant Test Data	
<p>1. Freeboard – The distance measured perpendicularly from the surface of the water to the lowest point of the subject's mouth where respiration may be impeded, if the mouth were not held shut. The lowest side of the mouth should be measured if the left and right sides are not level.</p> <p>2. Faceplane angle – The angle, relative to the surface of the water, of the plane formed between the most forward part of the forehead and chin.</p> <p>3. Torso angle – The angle, relative to vertical, of the line formed by the forward points of the shoulder and hipbone (ilium portion of the pelvis).</p> <p>4. List angle – The angle relative to the surface of the water and a line between the left and right shoulder or a line through the ears if only the head is tilted.</p>	<p>Freeboard: the average freeboard of all the subjects should not be less than the average for the RTD minus 10 mm.</p> <p>Faceplane Angles: The average of all subjects' faceplane angles should be not less than the average for the RTD minus 10°.</p> <p>Torso Angles: the average of all subjects' torso angles should be not less than the average for the RTD minus 10°.</p> <p>Lifejacket light location: the position of the lifejacket light should permit it to be visible over as great a segment of the upper hemisphere as is practicable.</p>	<p>Average freeboard, all subjects <math>\geq</math> average freeboard for RTD minus 10 mm</p> <p>Passed_____ Failed_____</p> <p>Average faceplane angle, all subjects <math>\geq</math> average for RTD minus 10°</p> <p>Passed_____ Failed_____</p> <p>Average torso angles, all subjects <math>\geq</math> average for RTD minus 10°</p> <p>Passed_____ Failed_____</p> <p>Does the location of the lifejacket light permit it to be visible over as great a segment of the upper hemisphere as practicable?</p> <p>Comments/Observations</p>	

<b>Inherently buoyant lifejackets</b>	Manufacturer: _____ Model: _____ Lot/Serial Number: _____	Date: _____ Time: _____ Surveyor: _____ Organization: _____
<b>2.2.1.19 Water performance tests – Jump and drop tests</b>		<b>Regulations: LSA Code II/ 2.2.1.5.6; MSC.81(70)1/2.8.8 and 2.8.9</b>
<b>Test Procedure</b>	<b>Acceptance Criteria</b>	<b>Significant Test Data</b>
<p>Without readjusting the lifejacket, the test subject should jump vertically into the water, feet first, from a height of at least 1m while holding the arms over the head. Upon entering the water, the test subject should relax to simulate a state of utter exhaustion. The freeboard to the mouth should be recorded after the test subject comes to rest. The test should be repeated from a height of at least 4.5 m.</p> <p>When jumping into the water, the test subject should hold on to the lifejacket during water entry to avoid possible injury. Upon entering the water, the test subject should relax to simulate a state of utter exhaustion. The freeboard to the mouth should be recorded after the test subject comes to rest.</p> <p>The lifejacket and its attachments should be examined for any damage. If injury is believed likely from any jump or drop test, the lifejacket should be rejected or the test delayed until test from a lower height or with additional precautions demonstrate that the risk from the required test is acceptable.</p> <p><b>NOTE: JUMP TESTS SHOULD NOT BE REPEATED IN THE RTD.</b></p>	<p>Following the jump and drop test, the lifejacket should:</p> <p>.1 surface the test subject in a face up position with an average freeboard for all the subjects of not less than the average determined for the RTD after the turning test in accordance with 2.2.1.18 minus 15 mm;</p> <p>.2 not be dislodged or cause harm to the test subject;</p> <p>.3 have no damage that would affect its in-water performance or buoyance; and</p> <p>.4 have no damage to its attachments.</p>	<p>See following page for test data</p> <p>1 m Jump</p> <p>Average freeboard, all subjects: _____ mm (A)          Average freeboard for RTD (from 2.2.1.18): _____ mm (B)          (B) – (A)= _____ ≤ 15 mm Pass / Fail</p> <p>Did the lifejacket become dislodged or cause harm to the test subject?:          Yes / No</p> <p>Did the lifejacket have damage that would affect its in-water performance or buoyance?: Yes / No</p> <p>Did the lifejacket have damage to its attachments?: Yes / No</p> <p>4.5 m Jump</p> <p>Average freeboard, all subjects: _____ mm (A)          Average freeboard for RTD (from 2.2.1.18) : _____ mm (B)          (B) – (A)= _____ ≤ 15 mm Pass / Fail</p> <p>Did the lifejacket become dislodged or cause harm to the test subject?: Yes / No</p> <p>Did the lifejacket have damage that would affect its in-water performance or buoyance?: Yes / No</p> <p>Did the lifejacket have damage to its attachments?: Yes / No</p> <p>Comments/Observations</p>

<b>Inherently buoyant lifejackets</b>		Manufacturer: _____ Model: _____ Lot/Serial Number: _____			Date: _____ Time: _____ Surveyor: _____ Organization: _____	
<b>2.2.1.19 Water performance tests – Jump and drop tests</b>				<b>Regulations: LSA Code II/ 2.2.1.5.6; MSC.81(70)1/2.8.8 and 2.8.9</b>		
<b>TEST DATA SHEET (1 m Jump)</b>						
Subj	Subject surfaced faceup? (Yes/No)	Freeboard (mm)	Lifejacket became dislodged (Yes/No)	Subject was harmed? (Yes/No)	Damage to lifejacket or attachments (Yes/No)	Comments/ Observations
1						
2						
3						
4						
5						
6						
7						
8						
9						
10						
11						
12						

<b>Inherently buoyant lifejackets</b>		Manufacturer: _____ Model: _____ Lot/Serial Number: _____			Date: _____ Time: _____ Surveyor: _____ Organization: _____	
<b>2.2.1.19 Water performance tests – Jump and drop tests (Continued)</b>				<b>Regulations: LSA Code II/ 2.2.1.5.6; MSC.81(70)1/2.8.8 and 2.8.9</b>		
<b>TEST DATA SHEET (4.5 m Jump)</b>						
Subj	Subject surfaced faceup? (Yes/No)	Freeboard (mm)	Lifejacket became dislodged (Yes/No)	Subject was harmed? (Yes/No)	Damage to lifejacket or attachments (Yes/No)	Comments/ Observations
1						
2						
3						
4						
5						
6						
7						
8						
9						
10						
11						
12						

<b>Inherently buoyant lifejackets</b>	Manufacturer: _____ Model: _____ Lot/Serial Number: _____	Date: _____ Time: _____ Surveyor: _____ Organization: _____																																																																																																																																														
<b>2.2.1.20 Water performance tests – Stability test</b>		<b>Regulations: LSA Code II/2.2.1.4; MSC.81(70) 1/2.8.10</b>																																																																																																																																														
Test Procedure	Acceptance Criteria	Significant Test Data																																																																																																																																														
<p>The test subject should attain a relaxed face-up position of static balance in the water. The subject should be instructed to assume a foetal position as follows: "place your elbows against your sides, your hands on your stomach, under the lifejacket if possible, and bring your knees up as close to your chest as possible."</p> <p>The subject should be rotated clockwise around the longitudinal axis of the torso by grasping the subject's shoulders or upper areas of the lifejacket so that the subject attains a <math>55 \pm 5</math> degree list. The subject should then be released. The subject should return to a stable face-up position.</p> <p>The test should then be conducted with the subject rotated counter-clockwise.</p> <p>The entire test should then be repeated with the test subject wearing the RTD.</p>	<p>The candidate lifejacket should not roll any subject face down in the water.</p> <p style="text-align:center;">(a) + (b) = 0</p> <p>The number of subjects who are returned to the stable face-up foetal position in the candidate lifejacket should be at least equal to the number who are returned to the stable face-up foetal position in the RTD.</p> <p style="text-align:center;">(e) ≤ (g) And (f) ≤ (h)</p>	<table border="1" style="width:100%; border-collapse: collapse; text-align:center;"> <thead> <tr> <th rowspan="3">Subj</th> <th colspan="4">Did the subject roll face-down? (Yes/No)</th> <th colspan="4">Did the subject return to a stable face-up position? (Yes/No)</th> </tr> <tr> <th colspan="2">Candidate</th> <th colspan="2">RTD</th> <th colspan="2">Candidate</th> <th colspan="2">RTD</th> </tr> <tr> <th>CW</th> <th>CCW</th> <th>CW</th> <th>CCW</th> <th>CW</th> <th>CCW</th> <th>CW</th> <th>CCW</th> </tr> </thead> <tbody> <tr><td>1</td><td></td><td></td><td></td><td></td><td></td><td></td><td></td><td></td></tr> <tr><td>2</td><td></td><td></td><td></td><td></td><td></td><td></td><td></td><td></td></tr> <tr><td>3</td><td></td><td></td><td></td><td></td><td></td><td></td><td></td><td></td></tr> <tr><td>4</td><td></td><td></td><td></td><td></td><td></td><td></td><td></td><td></td></tr> <tr><td>5</td><td></td><td></td><td></td><td></td><td></td><td></td><td></td><td></td></tr> <tr><td>6</td><td></td><td></td><td></td><td></td><td></td><td></td><td></td><td></td></tr> <tr><td>7</td><td></td><td></td><td></td><td></td><td></td><td></td><td></td><td></td></tr> <tr><td>8</td><td></td><td></td><td></td><td></td><td></td><td></td><td></td><td></td></tr> <tr><td>9</td><td></td><td></td><td></td><td></td><td></td><td></td><td></td><td></td></tr> <tr><td>10</td><td></td><td></td><td></td><td></td><td></td><td></td><td></td><td></td></tr> <tr><td>11</td><td></td><td></td><td></td><td></td><td></td><td></td><td></td><td></td></tr> <tr><td>12</td><td></td><td></td><td></td><td></td><td></td><td></td><td></td><td></td></tr> <tr> <td>Total "No"</td> <td>(a)</td> <td>(b)</td> <td>(c)</td> <td>(d)</td> <td>(e)</td> <td>(f)</td> <td>(g)</td> <td>(h)</td> </tr> </tbody> </table>	Subj	Did the subject roll face-down? (Yes/No)				Did the subject return to a stable face-up position? (Yes/No)				Candidate		RTD		Candidate		RTD		CW	CCW	CW	CCW	CW	CCW	CW	CCW	1									2									3									4									5									6									7									8									9									10									11									12									Total "No"	(a)	(b)	(c)	(d)	(e)	(f)	(g)	(h)
Subj	Did the subject roll face-down? (Yes/No)				Did the subject return to a stable face-up position? (Yes/No)																																																																																																																																											
	Candidate			RTD		Candidate		RTD																																																																																																																																								
	CW	CCW	CW	CCW	CW	CCW	CW	CCW																																																																																																																																								
1																																																																																																																																																
2																																																																																																																																																
3																																																																																																																																																
4																																																																																																																																																
5																																																																																																																																																
6																																																																																																																																																
7																																																																																																																																																
8																																																																																																																																																
9																																																																																																																																																
10																																																																																																																																																
11																																																																																																																																																
12																																																																																																																																																
Total "No"	(a)	(b)	(c)	(d)	(e)	(f)	(g)	(h)																																																																																																																																								

<b>Inherently buoyant lifejackets</b>	Manufacturer: _____ Model: _____ Lot/Serial Number: _____	Date: _____ Time: _____ Surveyor: _____ Organization: _____																																													
<b>2.2.1.21 Water performance tests -swimming and water emergence test</b>		<b>Regulations: LSA Code II/2.2.1.4; MSC.81(70) 1/2.8.11</b>																																													
Test Procedure	Acceptance Criteria	Significant Test Data																																													
<p>All test subjects, without wearing the lifejacket, should attempt to swim 25 m and board a liferaft or rigid platform with its surface 300 mm above the water surface. All test subjects who successfully complete this task should perform it again wearing the lifejacket.</p>	<p>At least two-thirds of the subjects who can accomplish the task without the lifejacket should also be able to perform it with the lifejacket.  (b) ≥ 2/3 (a)</p>	<p>Apparatus Used: _____ Liferaft or Rigid Platform</p> <p>Record whether test subjects can successfully board liferaft or platform:</p> <table border="1" style="width:100%; border-collapse: collapse;"> <thead> <tr> <th style="width:10%;">Subj</th> <th style="width:20%;">Without lifejacket</th> <th style="width:20%;">With lifejacket</th> <th style="width:50%;"></th> </tr> </thead> <tbody> <tr><td>1</td><td></td><td></td><td rowspan="12" style="vertical-align: top;">           (b) _____            2/3 (a) _____            Passed / Failed         </td></tr> <tr><td>2</td><td></td><td></td></tr> <tr><td>3</td><td></td><td></td></tr> <tr><td>4</td><td></td><td></td></tr> <tr><td>5</td><td></td><td></td></tr> <tr><td>6</td><td></td><td></td></tr> <tr><td>7</td><td></td><td></td></tr> <tr><td>8</td><td></td><td></td></tr> <tr><td>9</td><td></td><td></td></tr> <tr><td>10</td><td></td><td></td></tr> <tr><td>11</td><td></td><td></td></tr> <tr><td>12</td><td></td><td></td></tr> <tr> <td><b>Total</b></td> <td>(a) _____</td> <td>(b) _____</td> <td></td> </tr> </tbody> </table> <p>Comments/Observations</p>	Subj	Without lifejacket	With lifejacket		1			(b) _____ 2/3 (a) _____ Passed / Failed	2			3			4			5			6			7			8			9			10			11			12			<b>Total</b>	(a) _____	(b) _____	
Subj	Without lifejacket	With lifejacket																																													
1			(b) _____ 2/3 (a) _____ Passed / Failed																																												
2																																															
3																																															
4																																															
5																																															
6																																															
7																																															
8																																															
9																																															
10																																															
11																																															
12																																															
<b>Total</b>	(a) _____	(b) _____																																													



<b>Inherently buoyant lifejackets</b>	Manufacturer: _____ Model: _____ Lot/Serial Number: _____	Date: _____ Time: _____ Surveyor: _____ Organization: _____
---------------------------------------	---	---

<b>2.2.1.22 Infant and children's lifejacket - Test subjects selection</b>	<b>Regulations: LSA Code II/2.2.1.8; MSC.81(70) 1/2.9 – 2.9.1</b>
--	---

Test Procedure	Acceptance Criteria	Significant Test Data																																																																																																																																																																
<p>As far as possible, similar tests (to the adult tests) should be applied for approval of lifejackets suitable for infants and children.</p> <p>For child-size lifejackets, tests should be carried out with at least 9 able-bodied persons, and for infant-size lifejackets, tests should be carried out with at least 5 able-bodied persons.</p> <p>All test subjects should be selected according to table 2.2 or table 2.3 as follows:</p> <ol style="list-style-type: none"> <li>.1 One subject should be selected per each cell containing a "1".</li> <li>.2 Remaining subjects should be selected from cells containing an "X", without repeating a cell.</li> <li>.3 At least 40% of the subjects should be male and at least 40% female.</li> <li>.4 Devices for infants should be tested on infants as small as 6 kg mass.</li> </ol>	<p><b>Table 2.2 - Selection of Child Test Subjects</b></p> <table border="1" style="margin: auto; border-collapse: collapse;"> <thead> <tr> <th rowspan="2">Height range (cm)</th> <th colspan="11">Weight Range (kg)</th> </tr> <tr> <th>14-17</th> <th>17-20</th> <th>20-22</th> <th>22-25</th> <th>25-28</th> <th>28-30</th> <th>30-33</th> <th>33-36</th> <th>36-38</th> <th>38-41</th> <th>41-43</th> </tr> </thead> <tbody> <tr> <td>79-105</td> <td>1</td> <td>X</td> <td></td> <td></td> <td></td> <td></td> <td></td> <td></td> <td></td> <td></td> <td></td> </tr> <tr> <td>90-118</td> <td></td> <td>X</td> <td>1</td> <td></td> <td></td> <td></td> <td></td> <td></td> <td></td> <td></td> <td></td> </tr> <tr> <td>102-130</td> <td></td> <td></td> <td></td> <td>1</td> <td>X</td> <td></td> <td></td> <td></td> <td></td> <td></td> <td></td> </tr> <tr> <td>112-135</td> <td></td> <td></td> <td></td> <td></td> <td>X</td> <td>1</td> <td></td> <td></td> <td></td> <td></td> <td></td> </tr> <tr> <td>122-150</td> <td></td> <td></td> <td></td> <td></td> <td></td> <td></td> <td>1</td> <td>1</td> <td>X</td> <td></td> <td></td> </tr> <tr> <td>145-165</td> <td></td> <td></td> <td></td> <td></td> <td></td> <td></td> <td></td> <td></td> <td>X</td> <td>1</td> <td>1</td> </tr> </tbody> </table>	Height range (cm)	Weight Range (kg)											14-17	17-20	20-22	22-25	25-28	28-30	30-33	33-36	36-38	38-41	41-43	79-105	1	X										90-118		X	1									102-130				1	X							112-135					X	1						122-150							1	1	X			145-165									X	1	1	<p>Size: Infant / Child</p> <table border="1" style="width:100%; border-collapse: collapse; margin-top: 10px;"> <thead> <tr> <th>Subj</th> <th>SEX (M/F)</th> <th>HEIGHT (m)</th> <th>WEIGHT (kg)</th> <th>Manikin? (Yes*/No)</th> </tr> </thead> <tbody> <tr><td>1</td><td></td><td></td><td></td><td></td></tr> <tr><td>2</td><td></td><td></td><td></td><td></td></tr> <tr><td>3</td><td></td><td></td><td></td><td></td></tr> <tr><td>4</td><td></td><td></td><td></td><td></td></tr> <tr><td>5</td><td></td><td></td><td></td><td></td></tr> <tr><td>6</td><td></td><td></td><td></td><td></td></tr> <tr><td>7</td><td></td><td></td><td></td><td></td></tr> <tr><td>8</td><td></td><td></td><td></td><td></td></tr> <tr><td>9</td><td></td><td></td><td></td><td></td></tr> <tr><td></td><td></td><td></td><td></td><td></td></tr> <tr><td></td><td></td><td></td><td></td><td></td></tr> <tr><td></td><td></td><td></td><td></td><td></td></tr> </tbody> </table> <p style="margin-top: 10px;">*Manikin description: _____</p>	Subj	SEX (M/F)	HEIGHT (m)	WEIGHT (kg)	Manikin? (Yes*/No)	1					2					3					4					5					6					7					8					9																			
Height range (cm)	Weight Range (kg)																																																																																																																																																																	
	14-17	17-20	20-22	22-25	25-28	28-30	30-33	33-36	36-38	38-41	41-43																																																																																																																																																							
79-105	1	X																																																																																																																																																																
90-118		X	1																																																																																																																																																															
102-130				1	X																																																																																																																																																													
112-135					X	1																																																																																																																																																												
122-150							1	1	X																																																																																																																																																									
145-165									X	1	1																																																																																																																																																							
Subj	SEX (M/F)	HEIGHT (m)	WEIGHT (kg)	Manikin? (Yes*/No)																																																																																																																																																														
1																																																																																																																																																																		
2																																																																																																																																																																		
3																																																																																																																																																																		
4																																																																																																																																																																		
5																																																																																																																																																																		
6																																																																																																																																																																		
7																																																																																																																																																																		
8																																																																																																																																																																		
9																																																																																																																																																																		

2.2.1.22 Infant and children's lifejacket - Test subjects selection		Regulations: LSA Code II/2.2.1.8; MSC.81(70) 1/2.9 – 2.9.1		
Test Procedure	Acceptance Criteria			Significant Test Data
.5 A manikin or manikins may be substituted for test subjects if the manikin or manikins have been demonstrated to provide representative results compared to human subjects.	<b>Table 2.3 - Selection of Infant Test Subjects</b>			
	Height range (cm)	Weight Range (kg)		
		Less than 11	11-14	14-17
	Less than 83	1	X	
	79-105	X	1	1
90-118			X	

<b>Inherently buoyant lifejackets</b>	Manufacturer: _____ Model: _____ Lot/Serial Number: _____	Date: _____ Time: _____ Surveyor: _____ Organization: _____
<b>2.2.1.23 Infant and children's lifejacket – Water performance tests – Righting test</b>		<b>Regulations: LSA Code II/ 2.2.1.8; MSC.81(70)1/ 2.9.2-2.9.3, Annex 2, Annex 3</b>
<p style="text-align: center;">Test Procedure</p>	<p style="text-align: center;">Acceptance Criteria</p>	<p style="text-align: center;">Significant test data</p>
<p>This portion of the test is intended to determine the ability of the lifejacket to assist a helpless person or one in an exhausted or unconscious state and to show that the lifejacket does not unduly restrict movement.</p> <p>The in-water performance of a lifejacket is evaluated by comparison to the performance of a suitable size standard reference lifejacket, i.e. Reference Test Device (RTD) as specified in appendices 2 to 3.</p> <p>All tests should be carried out in fresh water under still conditions. Each test for a candidate lifejacket and the relevant RTD should be conducted on the same day.</p> <p>The tests may be modified for child test subjects under 12 years of age who are not comfortable in water, so as to ensure their safety and cooperation.</p> <p>Prior to taking measurements, the proper fit, donning, and fastening of the RTD on the subject should be checked and corrected as necessary.</p> <p>After entering the water, care should be taken to ensure that there is no significant amount of air unintentionally trapped in the lifejacket or swimming costume.</p>	<p>The RTD should be constructed and calibrated according to resolution MSC.81(70), annex 2 or 3, as applicable to the size.</p>	<p>RTD Size: Infant / Child</p> <p>RTD Constructed by: _____ date: _____</p> <p>Validated by: _____ date: _____</p> <p>Calibrated by: _____ date: _____</p>

<b>Inherently buoyant lifejackets</b>	Manufacturer: _____ Model: _____ Lot/Serial Number: _____	Date: _____ Time: _____ Surveyor: _____ Organization: _____																																																																																																																																																																																																																																														
<b>2.2.1.23 Infant and children's lifejacket – Water performance tests – Righting test (Continued)</b>		<b>Regulations: LSA Code II/ 2.2.1.8; MSC.81(70)1/ 2.9.2-2.9.3, Annex 2, Annex 3</b>																																																																																																																																																																																																																																														
<b>Test Procedure</b>	<b>Acceptance Criteria</b>	<b>Significant Test Data</b>																																																																																																																																																																																																																																														
<p>Each test subject should assume a prone, face down position in the water, but with the head lifted up so the mouth is out of the water. The subject's feet should be supported, shoulder width apart, with the heels just below the surface of the water.</p> <p>After assuming a starting position with the legs straight and arms along the sides, the subject should then be instructed in the following sequence to allow the body to gradually and completely relax into a natural floating posture: allow the arms and shoulders to relax; allow the legs to relax; and then the spine and neck, letting the head fall into the water while breathing out normally.</p> <p>During the relaxation phase, the subject should be maintained in a stable face down position.</p>	<p>The period of time until the mouth of the test subject comes clear of the water should be recorded to the nearest 1/10 of a second, starting from when the subject's feet are released.</p> <p>The test should be conducted a total of six times, and the highest and lowest times discarded. The test should then be conducted a total of six times in the RTD and the highest and lowest times discarded.</p> <p>Turning time: the average turn time for all subjects in the candidate lifejacket should not exceed the average time in the RTD plus 1 s.</p>	<table border="1" style="width:100%; border-collapse: collapse;"> <thead> <tr> <th rowspan="2" style="width:5%;">Subj</th> <th colspan="7" style="text-align:center;">CANDIDATE DEVICE TIME (sec) TRIAL</th> <th colspan="6" style="text-align:center;">REFERENCE VEST TIME (sec) TRIAL</th> </tr> <tr> <th>#1</th><th>#2</th><th>#3</th><th>#4</th><th>#5</th><th>#6</th><th>AVG *</th> <th>#1</th><th>#2</th><th>#3</th><th>#4</th><th>#5</th><th>#6</th><th>AVG *</th> </tr> </thead> <tbody> <tr><td>1</td><td></td><td></td><td></td><td></td><td></td><td></td><td></td><td></td><td></td><td></td><td></td><td></td><td></td><td></td></tr> <tr><td>2</td><td></td><td></td><td></td><td></td><td></td><td></td><td></td><td></td><td></td><td></td><td></td><td></td><td></td><td></td></tr> <tr><td>3</td><td></td><td></td><td></td><td></td><td></td><td></td><td></td><td></td><td></td><td></td><td></td><td></td><td></td><td></td></tr> <tr><td>4</td><td></td><td></td><td></td><td></td><td></td><td></td><td></td><td></td><td></td><td></td><td></td><td></td><td></td><td></td></tr> <tr><td>5</td><td></td><td></td><td></td><td></td><td></td><td></td><td></td><td></td><td></td><td></td><td></td><td></td><td></td><td></td></tr> <tr><td>6</td><td></td><td></td><td></td><td></td><td></td><td></td><td></td><td></td><td></td><td></td><td></td><td></td><td></td><td></td></tr> <tr><td>7</td><td></td><td></td><td></td><td></td><td></td><td></td><td></td><td></td><td></td><td></td><td></td><td></td><td></td><td></td></tr> <tr><td>8</td><td></td><td></td><td></td><td></td><td></td><td></td><td></td><td></td><td></td><td></td><td></td><td></td><td></td><td></td></tr> <tr><td>9</td><td></td><td></td><td></td><td></td><td></td><td></td><td></td><td></td><td></td><td></td><td></td><td></td><td></td><td></td></tr> <tr><td></td><td></td><td></td><td></td><td></td><td></td><td></td><td></td><td></td><td></td><td></td><td></td><td></td><td></td><td></td></tr> <tr><td></td><td></td><td></td><td></td><td></td><td></td><td></td><td></td><td></td><td></td><td></td><td></td><td></td><td></td><td></td></tr> <tr><td></td><td></td><td></td><td></td><td></td><td></td><td></td><td></td><td></td><td></td><td></td><td></td><td></td><td></td><td></td></tr> <tr> <td colspan="7" style="text-align:center;"><b>Average candidate turn time (sec):</b></td> <td></td> <td colspan="6" style="text-align:center;"><b>Average RTD turn time (sec):</b></td> <td></td> </tr> <tr> <td colspan="7" style="text-align:center;"><b># of candidate no turns (NT):</b></td> <td></td> <td colspan="6" style="text-align:center;"><b># of RTD no turns (NT):</b></td> <td></td> </tr> </tbody> </table>	Subj	CANDIDATE DEVICE TIME (sec) TRIAL							REFERENCE VEST TIME (sec) TRIAL						#1	#2	#3	#4	#5	#6	AVG *	#1	#2	#3	#4	#5	#6	AVG *	1															2															3															4															5															6															7															8															9																																																												<b>Average candidate turn time (sec):</b>								<b>Average RTD turn time (sec):</b>							<b># of candidate no turns (NT):</b>								<b># of RTD no turns (NT):</b>						
		Subj		CANDIDATE DEVICE TIME (sec) TRIAL							REFERENCE VEST TIME (sec) TRIAL																																																																																																																																																																																																																																					
			#1	#2	#3	#4	#5	#6	AVG *	#1	#2	#3	#4	#5	#6	AVG *																																																																																																																																																																																																																																
		1																																																																																																																																																																																																																																														
		2																																																																																																																																																																																																																																														
		3																																																																																																																																																																																																																																														
		4																																																																																																																																																																																																																																														
		5																																																																																																																																																																																																																																														
		6																																																																																																																																																																																																																																														
		7																																																																																																																																																																																																																																														
		8																																																																																																																																																																																																																																														
		9																																																																																																																																																																																																																																														
<b>Average candidate turn time (sec):</b>								<b>Average RTD turn time (sec):</b>																																																																																																																																																																																																																																								
<b># of candidate no turns (NT):</b>								<b># of RTD no turns (NT):</b>																																																																																																																																																																																																																																								
(* Delete highest and lowest value)																																																																																																																																																																																																																																																
Average candidate turn time ≤ Average RTD turn time RTD +1s    Passed _____    Failed _____																																																																																																																																																																																																																																																
# of candidate no turns (NT): ≤ # of RTD no turns (NT):                      Passed _____    Failed _____																																																																																																																																																																																																																																																

2.2.1.23 Infant and children's lifejacket – Water performance tests – Righting test (Continued)		Regulations: LSA Code II/ 2.2.1.8; MSC.81(70)/ 2.9.2-2.9.3, Annex 2, Annex 3
Test Procedure	Acceptance Criteria	Significant Test Data
Immediately after the subject has relaxed, with the face in the water, simulating a state of utter exhaustion, the subject's feet should be released.	The number of "no-turns", if any, should not exceed the number in the RTD.	Comments/Observations:

<b>Inherently buoyant lifejackets</b>	Manufacturer: _____ Model: _____ Lot/Serial Number: _____	Date: _____ Time: _____ Surveyor: _____ Organization: _____						
<b>2.2.1.24 Infant and children's lifejacket – Water performance tests – Static balance measurements</b>		<b>Regulations: LSA Code II/ 2.2.1.8; MSC.81(70)1/ 2.8.6, 2.9.2-2.9.3, Annex 2 &amp; 3</b>						
Test Procedure	Significant Test Data							
<p>At the conclusion of the righting tests, without making any adjustments in body or lifejacket position, the following measurements should be made with the subject floating in the relaxed face-up position of static balance resulting from the preceding tests.</p> <p>Infant lifejackets should meet the turning time and freeboard requirements, however, the requirements for torso angle, faceplane and mobility may be relaxed if necessary in order to:</p> <p>.1 contribute to the rescue of the infant by a caretaker;</p> <p>.2 allow the infant to be fastened to a caretaker and contribute to keeping the infant close to the caretaker;</p> <p>.3 keep the infant dry, with free respiratory passages;</p> <p>.4 protect the infant against bumps and jolts during the evacuation; and</p> <p>.5 allow a caretaker to monitor and control heat loss by the infant.</p>		Freeboard (mm)		Faceplane (deg)		Torso angle (deg)		Light
		CLJ	RTD	CLJ	RTD	CLJ	RTD	Visible?
	1							
	2							
	3							
	4							
	5							
	6							
	7							
	8							
	9							
Avg							XXXXX	
CLJ – Candidate Lifejacket RTD – Reference Test Device								

<b>Inherently buoyant lifejackets</b>	Manufacturer: _____ Model: _____ Lot/Serial Number: _____	Date: _____ Time: _____ Surveyor: _____ Organization: _____
<b>2.2.1.24 Infant and children's lifejacket - Water performance tests – Static balance measurements (Continued)</b>		<b>Regulations: LSA Code II/ 2.2.1.8; MSC.81(70)1/ 2.8.6, 2.9.2-2.9.3, Annex 2 &amp; 3</b>
Test Procedure	Acceptance Criteria	Significant Test Data
<ol style="list-style-type: none"> <li>1. Freeboard – The distance measured perpendicularly from the surface of the water to the lowest point of the subject's mouth where respiration may be impeded, if the mouth were not held shut. The lowest side of the mouth should be measured if the left and right sides are not level.</li> <li>2. Faceplane angle – The angle, relative to the surface of the water, of the plane formed between the most forward part of the forehead and chin.</li> <li>3. Torso angle – The angle, relative to vertical, of the line formed by the forward points of the shoulder and hipbone (ilium portion of the pelvis).</li> <li>4. List angle – The angle relative to the surface of the water and a line between the left and right shoulder or a line through the ears if only the head is tilted.</li> </ol>	<p>Freeboard: the average freeboard of all the subjects should not be less than the average for the RTD minus 10 mm</p> <p>Faceplane Angles: The average of all subjects' faceplane angles should be not less than the average for the RTD minus 10°</p> <p>Torso Angles: the average of all subjects' torso angles should be not less than the average for the RTD minus 10°</p> <p>Lifejacket light location: the position of the lifejacket light should permit it to be visible over as great a segment of the upper hemisphere as is practicable.</p>	<p>Average freeboard, all subjects <math>\geq</math> average freeboard for RTD minus 10 mm</p> <p>Passed _____ Failed _____</p> <p>Average faceplane angle, all subjects <math>\geq</math> average for RTD minus 10°</p> <p>Passed _____ Failed _____</p> <p>Average torso angles, all subjects <math>\geq</math> average for RTD minus 10°</p> <p>Passed _____ Failed _____</p> <p>Does the location of the lifejacket light permit it to be visible over as great a segment of the upper hemisphere as practicable?</p> <p>Comments/Observations:</p>

<b>Inherently buoyant lifejackets</b>	Manufacturer: _____ Model: _____ Lot/Serial Number: _____	Date: _____ Time: _____ Surveyor: _____ Organization: _____
<b>2.2.1.25 Children's lifejacket – Water performance tests – Jump and drop test</b>		<b>Regulations: LSA Code II/2.2.1.8, 2.2.1.5.6; MSC.81(70) 1/ 2.9, 2.8.8, 2.8.9</b>
Test Procedure	Acceptance Criteria	Significant Test Data
<p>Without readjusting the lifejacket, the test subject should jump vertically into the water, feet first, from a height of at least 1m while holding the arms over the head. Upon entering the water, the test subject should relax to simulate a state of utter exhaustion. The freeboard to the mouth should be recorded after the test subject comes to rest. The test should be repeated from a height of at least 4.5m.</p> <p>When jumping into the water, the test subject should hold on to the lifejacket during water entry to avoid possible injury. Upon entering the water, the test subject should relax to simulate a state of utter exhaustion. The freeboard to the mouth should be recorded after the test subject comes to rest.</p> <p>The lifejacket and its attachments should be examined for any damage. If injury is believed likely from any jump or drop test, the lifejacket should be rejected or the test delayed until test from a lower height or with additional precautions demonstrate that the risk from the required test is acceptable.</p> <p><u>NOTE: JUMP AND DROP TESTS SHOULD NOT BE REPEATED IN THE RTD.</u></p>	<p>Five of the nine subjects should perform the jump and drop test.</p> <p>When conducting water performance tests under 2.8, infant and child-size lifejackets should meet the following requirements for their critical flotation stability characteristics.</p> <p>Following the jump and drop test, the lifejacket should:</p> <p>.1 surface the test subject in a face up position with an average freeboard for all the subjects of not less than the average determined for the RTD after the turning test in accordance with 2.2.1.23 minus 15 mm;</p> <p>.2 not be dislodged or cause harm to the test subject;</p>	<p>See following page for test data</p> <p>1 m Jump</p> <p>Average freeboard, all subjects: _____ mm (A)          Average freeboard for RTD (from 2.2.18) : _____ mm (B)</p> <p>(B) – (A)= _____ ≤ 15 mm Pass / Fail</p> <p>Did the lifejacket become dislodged or cause harm to the test subject?:          Yes / No</p> <p>Did the lifejacket have damage that would affect its in-water performance or buoyance?: Yes / No</p> <p>Did the lifejacket have damage to its attachments?: Yes / No</p> <p>4.5 m Jump</p> <p>Average freeboard, all subjects: _____ mm (A)          Average freeboard for RTD (from 2.2.18) : _____ mm (B)</p> <p>(B) – (A)= _____ ≤ 15 mm Pass / Fail</p> <p>Did the lifejacket become dislodged or cause harm to the test subject?:          Yes / No</p> <p>Did the lifejacket have damage that would affect its in-water performance or buoyance?: Yes / No</p>



2.2.1.25 Children's lifejacket – Water performance tests – Jump and drop test		Regulations: LSA Code II/2.2.1.8, 2.2.1.5.6; MSC.81(70) 1/ 2.9, 2.8.8, 2.8.9
Test Procedure	Acceptance Criteria	Significant Test Data
Note: Water tests using children should avoid causing distress or risk to the child. Consideration should be taken of their age and ability.	.3 have no damage that would affect its in-water performance or buoyance; and  .4 have no damage to its attachments.	Did the lifejacket have damage to its attachments?: Yes / No  Comments/Observations

<b>Inherently buoyant lifejackets</b>	Manufacturer: _____ Model: _____ Lot/Serial Number: _____	Date: _____ Time: _____ Surveyor: _____ Organization: _____
---------------------------------------	---	---

<b>2.2.1.25 Children's lifejacket – Water performance tests – Jump and drop tests</b>	<b>Regulations: LSA Code II/ 2.2.1.8, 2.2.1.5.6; MSC.81(70)1/2.9, 2.8.8 and 2.8.9</b>
---	---

TEST DATA SHEET (1 m Jump)						
Subj	Subject surfaced faceup? (Yes/No)	Freeboard (mm)	Lifejacket became dislodged (Yes/No)	Subject was harmed? (Yes/No)	Damage to lifejacket or attachments (Yes/No)	Comments/ Observations
1						
2						
3						
4						
5						

<b>2.2.1.25 Children's lifejacket – Water performance tests – Jump and drop tests</b>	<b>Regulations: LSA Code II/ 2.2.1.8, 2.2.1.5.6; MSC.81(70)1/2.9, 2.8.8 and 2.8.9</b>
---	---

TEST DATA SHEET (4.5 m Jump)						
Subj	Subject surfaced faceup? (Yes/No)	Freeboard (mm)	Lifejacket became dislodged (Yes/No)	Subject was harmed? (Yes/No)	Damage to lifejacket or attachments (Yes/No)	Comments/ Observations
1						
2						
3						
4						
5						

<b>Inherently buoyant lifejackets</b>	Manufacturer: _____ Model: _____ Lot/Serial Number: _____	Date: _____ Time: _____ Surveyor: _____ Organization: _____																																																																																																																																														
<b>2.2.1.26 Infant and children's lifejacket – Water performance tests – Stability test</b>		<b>Regulations: LSA Code II/2.2.1.8, 2.2.1.4; MSC.81(70) 1/2.8.10, 2.9</b>																																																																																																																																														
Test Procedure	Acceptance Criteria	Significant Test Data																																																																																																																																														
<p>The test subject should attain a relaxed face-up position of static balance in the water. The subject should be instructed to assume a foetal position as follows: "place your elbows against your sides, your hands on your stomach, under the lifejacket if possible, and bring your knees up as close to your chest as possible."</p> <p>The subject should be rotated clockwise around the longitudinal axis of the torso by grasping the subject's shoulders or upper areas of the lifejacket so that the subject attains a 55 ± 5 degree list. The subject should then be released. The subject should return to a stable face-up position.</p> <p>The test should then be conducted with the subject rotated counter-clockwise.</p> <p>The entire test should then be repeated with the test subject wearing the RTD.</p>	<p>The candidate lifejacket should not roll any subject face down in the water.</p> <p style="text-align:center;">(a) + (b) = 0</p> <p>The number of subjects who are returned to the stable face-up foetal position in the candidate lifejacket should be at least equal to the number who are returned to the stable face-up foetal position in the RTD.</p> <p style="text-align:center;">(e) ≤ (g) And (f) ≤ (h)</p>	<table border="1" style="width:100%; border-collapse: collapse; text-align:center;"> <thead> <tr> <th rowspan="3">Subj</th> <th colspan="4">Did the subject roll face-down? (Yes/No)</th> <th colspan="4">Did the subject return to a stable face-up position? (Yes/No)</th> </tr> <tr> <th colspan="2">Candidate</th> <th colspan="2">RTD</th> <th colspan="2">Candidate</th> <th colspan="2">RTD</th> </tr> <tr> <th>CW</th> <th>CCW</th> <th>CW</th> <th>CCW</th> <th>CW</th> <th>CCW</th> <th>CW</th> <th>CCW</th> </tr> </thead> <tbody> <tr><td>1</td><td></td><td></td><td></td><td></td><td></td><td></td><td></td><td></td></tr> <tr><td>2</td><td></td><td></td><td></td><td></td><td></td><td></td><td></td><td></td></tr> <tr><td>3</td><td></td><td></td><td></td><td></td><td></td><td></td><td></td><td></td></tr> <tr><td>4</td><td></td><td></td><td></td><td></td><td></td><td></td><td></td><td></td></tr> <tr><td>5</td><td></td><td></td><td></td><td></td><td></td><td></td><td></td><td></td></tr> <tr><td>6</td><td></td><td></td><td></td><td></td><td></td><td></td><td></td><td></td></tr> <tr><td>7</td><td></td><td></td><td></td><td></td><td></td><td></td><td></td><td></td></tr> <tr><td>8</td><td></td><td></td><td></td><td></td><td></td><td></td><td></td><td></td></tr> <tr><td>9</td><td></td><td></td><td></td><td></td><td></td><td></td><td></td><td></td></tr> <tr><td></td><td></td><td></td><td></td><td></td><td></td><td></td><td></td><td></td></tr> <tr><td></td><td></td><td></td><td></td><td></td><td></td><td></td><td></td><td></td></tr> <tr><td></td><td></td><td></td><td></td><td></td><td></td><td></td><td></td><td></td></tr> <tr> <td>Total "No"</td> <td>(a)</td> <td>(b)</td> <td>(c)</td> <td>(d)</td> <td>(e)</td> <td>(f)</td> <td>(g)</td> <td>(h)</td> </tr> </tbody> </table>	Subj	Did the subject roll face-down? (Yes/No)				Did the subject return to a stable face-up position? (Yes/No)				Candidate		RTD		Candidate		RTD		CW	CCW	CW	CCW	CW	CCW	CW	CCW	1									2									3									4									5									6									7									8									9																																				Total "No"	(a)	(b)	(c)	(d)	(e)	(f)	(g)	(h)
Subj	Did the subject roll face-down? (Yes/No)				Did the subject return to a stable face-up position? (Yes/No)																																																																																																																																											
	Candidate			RTD		Candidate		RTD																																																																																																																																								
	CW	CCW	CW	CCW	CW	CCW	CW	CCW																																																																																																																																								
1																																																																																																																																																
2																																																																																																																																																
3																																																																																																																																																
4																																																																																																																																																
5																																																																																																																																																
6																																																																																																																																																
7																																																																																																																																																
8																																																																																																																																																
9																																																																																																																																																
Total "No"	(a)	(b)	(c)	(d)	(e)	(f)	(g)	(h)																																																																																																																																								

<b>Inherently buoyant lifejackets</b>	Manufacturer: _____ Model: _____ Lot/Serial Number: _____	Date: _____ Time: _____ Surveyor: _____ Organization: _____
<b>2.2.1.27 Infant and children's lifejacket - Mobility test</b>		<b>Regulations: LSA Code II/2.2.1.8; MSC.81(70) 1/2.9.2.5</b>
Test Procedure	Acceptance Criteria	Significant Test Data
<p>To be considered in and out of the water.</p> <p>Mobility of the subject both in and out of the water should be given consideration in determining the acceptability of a device for approval and should be compared to mobility when wearing the appropriate size RTD when climbing out of the water, going up and down stairs, picking up an article from the floor, and then drinking from a cup.</p>	<p>Assistance may be given to board a survival craft, but wearer mobility should not be reduced to any greater extent than by the appropriate size RTD.</p>	<p>Does the lifejacket provide for acceptable mobility of the test subjects both in and out of the water and is comparative to the mobility of wearing the RTD?</p> <p style="text-align: center;">YES <input type="checkbox"/> NO <input type="checkbox"/></p> <p>Passed _____ Failed _____</p> <p>Method of evaluation:</p> <p>Comments/Observations</p>

## **2.2.2 INFLATABLE LIFEJACKETS (ADULTS & CHILD) EVALUATION AND TEST REPORT**

- 2.2.2.1 Submitted drawings, reports and documents
- 2.2.2.2 Quality assurance
- 2.2.2.3 Visual inspection
- 2.2.2.4 General data and specification
- 2.2.2.5 Temperature cycling test
  - 2.2.2.5.1 Inflation system function
  - 2.2.2.5.2 Test data
- 2.2.2.6 Buoyancy test
- 2.2.2.7 Fire test
- 2.2.2.8 Oil resistance test
- 2.2.2.9 Test of materials for inflatable bladders, inflation systems and components
  - 2.2.2.9.1 Coated fabrics test
  - 2.2.2.9.2 Operating head load test
  - 2.2.2.9.3 Pressure test
  - 2.2.2.9.4 Compression test
  - 2.2.2.9.5 Test of metallic components
  - 2.2.2.9.6 Inadvertent inflation test
- 2.2.2.10 Strength tests - Body or lifting loop strength test
- 2.2.2.11 Strength tests - Shoulder lift test
- 2.2.2.12 Donning test (Uninflated situation)
- 2.2.2.13 Donning test (Inflated situation)
- 2.2.2.14 Water performance tests – Preparation for water performance test
- 2.2.2.15 Water performance tests – Righting test
- 2.2.2.16 Water performance tests – Static balance measurements
- 2.2.2.17 Water performance tests – Jump and drop test
- 2.2.2.18 Water performance tests – Stability test
- 2.2.2.19 Water performance tests – Swimming and water emergence test
- 2.2.2.20 Infant and children's lifejacket – Test subjects
- 2.2.2.21 Infant and children's lifejacket – Water performance tests - Righting test
- 2.2.2.22 Infant and children's lifejacket – Water performance tests – Static balance measurements
- 2.2.2.23 Children's lifejacket – Water performance tests – Jump and drop test
- 2.2.2.24 Infant and children's lifejacket – Water performance tests – Stability test
- 2.2.2.25 Infant and children's lifejacket – Mobility test

**2.2.2 INFLATABLE LIFEJACKETS (ADULTS & CHILD)**  
**EVALUATION AND TEST REPORT**

<b>Manufacturer</b>	
<b>Type</b>	
<b>Date</b>	
<b>Place</b>	
<b>Name Surveyor printed</b>	
<b>Signature</b>	
<b>Approving Organization</b>	

<b>Inflatable lifejackets (Adults &amp; Child)</b>	Manufacturer: _____	Date: _____ Time: _____
	Model: _____	Surveyor: _____
	Lot/Serial Number: _____	Organization: _____

**2.2.2.1 Submitted drawings, reports and documents**

<b>Submitted drawings and documents</b>			<b>Status</b>
<b>Drawing No.</b>	<b>Revision No. &amp; date</b>	<b>Title of drawing</b>	
<b>Submitted reports and documents</b>			<b>Status</b>
<b>Report/Document No.</b>	<b>Revision No. &amp; date</b>	<b>Title of report / document</b>	
		Maintenance Manual -	
		Operations Manual -	

<b>Inflatable lifejackets (Adults &amp; Child)</b>	Manufacturer: _____ Model: _____ Lot/Serial Number: _____	Date: _____ Time: _____ Surveyor: _____ Organization: _____
<b>2.2.2.2 Quality assurance</b>		<b>Regulations: - MSC.81(70) 2/1.1, 1.2</b>
<p>Except where all appliances of a particular type are required by Chapter III of the International Convention for the Safety of Life at Sea, 1974, as amended, or the international Life-Saving Appliance (LSA) Code to be inspected, representatives of the Administration should make random inspections of manufacturers to ensure that the quality of life-saving appliances and materials used comply with the specification of the approved prototype life-saving appliance.</p> <p>Manufacturers should be required to institute a quality control procedure to ensure that life-saving appliances are produced to the same standard as the prototype life-saving appliance approved by the Administration and to keep records of any production tests carried out in accordance with the Administration's instructions.</p>		<p>Quality Assurance</p> <p>Standard Used:</p> <p>Quality Assurance Procedure:</p> <p>Quality Assurance Manual:</p> <p>Description of System:</p> <p>Quality Assurance System acceptable Yes/No</p> <p>Comments/Observations</p>



<b>Inflatable lifejackets (Adults &amp; Child)</b>	Manufacturer: _____ Model: _____ Lot/Serial Number: _____	Date: _____ Time: _____ Surveyor: _____ Organization: _____
<b>2.2.2.3 Visual inspection</b>		<b>Regulations: LSA Code I/1.2.2 &amp; II/2.2</b>
Test Procedure	Acceptance Criteria	Significant Test Data
1. Approval markings	Inflatable lifejackets should:  be clearly marked with approval information including the Administration which approved it, date of manufacturer and any operational restrictions	Passed _____      Failed _____
2. Retro-reflective tape	be fitted with approved patches of retro-reflective material with a total area of at least 400 cm <sup>2</sup> according to resolution A.658(16). In the case of a reversible lifejacket, the arrangement should be complied with no matter which way the lifejacket is put on. Such material should be placed as high on the lifejacket as possible.	Passed _____      Failed _____
3. Lifejacket light	have provision to be fitted with a light.	Passed _____      Failed _____
4. Donning and comfort	be so constructed that it is capable of being worn inside out or is clearly capable of being worn in one way and, if donned incorrectly, it is not injurious to the wearer. It should also be comfortable to wear;	Passed _____      Failed _____
5. Whistle	be fitted with a whistle firmly secured by a lanyard to the lifejacket.	Passed _____      Failed _____
6. Colour of lifejacket	be of international or vivid reddish orange or a comparably highly visible colour	Passed _____      Failed _____
		Passed _____      Failed _____

7. Buoyant Line & Means to lift the wearer	A lifejacket shall be provided with a releasable buoyant line or other means to secure it to a lifejacket worn by another person in the water. A lifejacket shall be provided with a suitable means to allow a rescuer to lift the wearer from the water into a survival craft or rescue boat.	Passed _____ Failed _____
8. Oversized lifejacket	If an adult life jacket is not designed to fit persons weighing up to 140 kg and with a chest girth of up to 1750 mm, suitable accessories shall be available to allow it to be secured to such persons.	Passed _____ Failed _____
9. Damaged in stowage and operation	A lifejacket shall not be damaged in stowage throughout the air temperature range -30°C to +65°C and remain operational throughout the air temperature range -15°C to +40°C. (After testing of temperature cycling.)	Comments/Observations



<b>Inflatable lifejackets (Adults &amp; Child)</b>	Manufacturer: _____ Model: _____ Lot/Serial Number: _____	Date: _____ Time: _____ Surveyor: _____ Organization: _____
<b>2.2.2.5 Temperature cycling test</b>		<b>Regulations: LSA Code I/1.2.2.2 &amp; 1.2.2.3; MSC.81(70) 1/2.10.1.1</b>
Test Procedure	Acceptance Criteria	Significant Test Data
<p>Two inflatable lifejackets should be subjected to a temperature cycling test of surrounding temperatures of -30°C and +65°C in the uninflated condition. These alternating cycles need not follow immediately after each other and the following procedure, repeated for a total of 10 cycles, is acceptable:</p> <ol style="list-style-type: none"> <li>1. an 8 h exposure at a minimum temperature of +65°C to be completed in one day; and</li> <li>2. the specimens removed from the warm chamber that same day and left exposed under ordinary room conditions at a temperature of 20°C ± 3°C until the next day;</li> <li>3. an 8 h exposure at a maximum temperature of -30°C to be completed the next day; and</li> <li>4. the specimen removed from the cold chamber that same day and left exposed under ordinary room conditions at a temperature of 20°C ± 3°C until the next day;</li> </ol>	<p>Two uninflated inflatable lifejackets after completion of the temperature cycling should be examined externally. The inflatable lifejacket materials should show no signs of damage such as shrinking, cracking, swelling dissolution or changes of mechanical qualities.</p> <p>Temperature test data sheet on next page.</p>	<p>Examination</p> <ol style="list-style-type: none"> <li>1. Lifejacket No. 1              Passed _____ Failed _____</li> <li>2. Lifejacket No. 2              Passed _____ Failed _____</li> <li>3. Cold inflation test, auto inflation              Temperature of water ____°C.              Time to inflate and relief valves blowing ____ sec.              Auto inflation Passed_____Failed _____</li> <li>4. Cold inflation test, manual inflation              Temperature of water ____°C.              Time to inflate and relief valves blowing ____ sec              Manual inflation Passed_____Failed _____</li> </ol> <p>Comments/Observations</p>

<b>Inflatable lifejackets (Adults &amp; Child)</b>	Manufacturer: _____ Model: _____ Lot/Serial Number: _____	Date: _____ Time: _____ Surveyor: _____ Organization: _____
<b>2.2.2.5.1 Temperature cycling test - Inflation system function</b>		<b>Regulations: LSA Code I/1.2.2.2 &amp; 1.2.2.3; MSC.81(70) 1/2.10.1.1 - 2.10.1.3</b>
Test Procedure	Acceptance Criteria	Significant Test Data
<p>The automatic and manual inflation systems should each be tested immediately after each temperature cycling test as follows:</p> <ol style="list-style-type: none"> <li>1. After a high temperature cycle, the two inflatable lifejackets should be taken from the stowage temperature of + 65°C. One should be activated using the automatic inflation system by placing it in seawater at a temperature of + 30°C and the other should be activated using the manual inflation system.</li> <li>2. After a low temperature cycle, the two inflatable lifejackets should be taken from the stowage temperature of -30°C. One should be activated using the automatic inflation system by placing it in seawater at a temperature of - 1°C and the other should be activated using the manual inflation system.</li> </ol> <p>After exposure to a temperature of -15°C for a period of at least 8 h, two lifejacket should be activated using the manual inflation system and should fully inflate.</p> <p>After exposure to a temperature of +40 °C for a period of at least 8 h, two lifejackets should be activated using the manual inflation system and should fully inflate.</p>	<p>The lifejackets should function satisfactorily after these tests. Each should fully inflate.</p> <p>The lifejackets should function satisfactorily after these tests. Each should fully inflate.</p>	<p>.5 Hot inflation test, automatic inflation</p> <p>Temperature of water ____°C.</p> <p>Time to inflate and relief valves blowing ____ sec</p> <p>Automatic inflation Passed____Failed</p> <p>.6 Hot inflation test, manual inflation</p> <p>Temperature of water ____°C.</p> <p>Time to inflate and relief valves blowing ____ sec</p> <p>Manual inflation Passed____Failed</p> <p>.7 Exposure to temperature of -15°C for 8h</p> <p>Did the two lifejackets fully inflate using the manual inflation system? Passed_____ Failed_____</p> <p>.8 Exposure to temperature of +40°C for 8h</p> <p>Did the two lifejackets fully inflate using the manual inflation system? Passed_____ Failed_____</p>

<b>Inflatable lifejackets (Adults &amp; Child)</b>	Manufacturer: _____ Model: _____ Lot/Serial Number: _____	Date: _____ Time: _____ Surveyor: _____ Organization: _____
<b>2.2.2.5.2 Temperature cycling test – Test data</b>		<b>Regulations: LSA Code I/1.2.2.2 &amp; 1.2.2.3; MSC.81(70) 1/2.10.1.1</b>
	<b>HOT CYCLE</b>	<b>COLD CYCLE</b>
Cycle 1	Date In: _____ Time In: _____ Temperature: _____ °C Date Out: _____ Time Out: _____ Duration: _____ hours	Date In: _____ Time In: _____ Temperature: _____ °C Date Out: _____ Time Out: _____ Duration: _____ hours
Cycle 2	Date In: _____ Time In: _____ Temperature: _____ °C Date Out: _____ Time Out: _____ Duration: _____ hours	Date In: _____ Time In: _____ Temperature: _____ °C Date Out: _____ Time Out: _____ Duration: _____ hours
Cycle 3	Date In: _____ Time In: _____ Temperature: _____ °C Date Out: _____ Time Out: _____ Duration: _____ hours	Date In: _____ Time In: _____ Temperature: _____ °C Date Out: _____ Time Out: _____ Duration: _____ hours
Cycle 4	Date In: _____ Time In: _____ Temperature: _____ °C Date Out: _____ Time Out: _____ Duration: _____ hours	Date In: _____ Time In: _____ Temperature: _____ °C Date Out: _____ Time Out: _____ Duration: _____ hours
Cycle 5	Date In: _____ Time In: _____ Temperature: _____ °C Date Out: _____ Time Out: _____ Duration: _____ hours	Date In: _____ Time In: _____ Temperature: _____ °C Date Out: _____ Time Out: _____ Duration: _____ hours
Cycle 6	Date In: _____ Time In: _____ Temperature: _____ °C Date Out: _____ Time Out: _____ Duration: _____ hours	Date In: _____ Time In: _____ Temperature: _____ °C Date Out: _____ Time Out: _____ Duration: _____ hours
Cycle 7	Date In: _____ Time In: _____ Temperature: _____ °C Date Out: _____ Time Out: _____ Duration: _____ hours	Date In: _____ Time In: _____ Temperature: _____ °C Date Out: _____ Time Out: _____ Duration: _____ hours
Cycle 8	Date In: _____ Time In: _____ Temperature: _____ °C Date Out: _____ Time Out: _____ Duration: _____ hours	Date In: _____ Time In: _____ Temperature: _____ °C Date Out: _____ Time Out: _____ Duration: _____ hours
Cycle 9	Date In: _____ Time In: _____ Temperature: _____ °C Date Out: _____ Time Out: _____ Duration: _____ hours	Date In: _____ Time In: _____ Temperature: _____ °C Date Out: _____ Time Out: _____ Duration: _____ hours
Cycle 10	Date In: _____ Time In: _____ Temperature: _____ °C Date Out: _____ Time Out: _____ Duration: _____ hours	Date In: _____ Time In: _____ Temperature: _____ °C Date Out: _____ Time Out: _____ Duration: _____ hours

<b>Inflatable lifejackets (Adults &amp; Child)</b>	Manufacturer: _____ Model: _____ Lot/Serial Number: _____	Date: _____ Time: _____ Surveyor: _____ Organization: _____
<b>2.2.2.6 Buoyancy test</b>		<b>Regulations: LSA Code II/2.2.2.3, 2.2.2; MSC.81(70) 1/2.2, 2.10.1.1</b>
Test Procedure	Acceptance Criteria	Significant Test Data
<p>The two lifejackets subjected to temperature cycling and the hot and cold inflation test should then be used for the buoyancy test.</p> <p>The buoyancy of the two lifejackets should be measured before and after 24 h complete submersion to just below the surface in fresh water. The test to be repeated as many times as necessary to perform the test once with each compartment in the uninflated condition.</p> <p>A lifejacket subjected to this test should be inflated automatically with one compartment uninflated, and the test should be repeated until each compartment has been tested in the uninflated condition.</p> <p>(The following equipment and procedure, or suitable alternatives may be used to carry out the buoyancy test of the lifejacket:</p> <ol style="list-style-type: none"> <li>1. a mesh basket or tray large enough to contain the lifejacket and adequate weights to overcome the buoyancy of the lifejacket;</li> <li>2. a tank of fresh water large enough to accommodate the basket or tray and the lifejacket with the uppermost part of the lifejacket 50 mm below the surface of the water; and</li> <li>3. a spring balance accurate to <math>\pm 0.015</math> kg.</li> <li>4. water temperature to be recorded at the start of each test and then after 24 hours on completion of each test.)</li> </ol>	<p>The difference between the initial buoyancy and the final buoyancy should not exceed 5% of the initial buoyancy.</p> <p>The chamber should be fitted with correct gas cylinder.</p>	<ol style="list-style-type: none"> <li>1. Lifejacket No.1           <p>Weight of the mesh basket with the lifejacket: _____Kg              Weight of the mesh basket without the lifejacket: _____Kg              Buoyancy of front chamber at start _____Kg.              Buoyancy of front chamber at 24 hr _____Kg.              Difference in buoyancy &lt; 5% _____Kg              Buoyancy of back chamber at start _____Kg.              Buoyancy of back chamber at 24 hr _____Kg.              Difference in buoyancy &lt; 5% _____Kg.</p> <p>Passed _____ Failed _____</p> </li> <li>2. Lifejacket No.2.           <p>Weight of the mesh basket with the lifejacket: _____Kg              Weight of the mesh basket without the lifejacket: _____Kg              Buoyancy of front chamber at start _____Kg              Buoyancy of front chamber at 24 hr _____Kg.              Difference in buoyancy &lt; 5% _____Kg              Buoyancy of back chamber at start _____Kg.              Buoyancy of back chamber at 24 hr _____Kg              Difference in buoyancy &lt; 5% _____Kg.</p> <p>Passed _____ Failed _____</p> </li> </ol> <p>Comments/Observations</p>

<b>Inflatable lifejackets (Adults &amp; Child)</b>	Manufacturer: _____ Model: _____ Lot/Serial Number: _____	Date: _____ Time: _____ Surveyor: _____ Organization: _____
<b>2.2.2.7 Fire test</b>		<b>Regulations: LSA Code II/2.2.1.1; MSC.81(70) 1/2.3, 2.10.1.1</b>
Test Procedure	Acceptance Criteria	Significant Test Data
<p>The chamber should be fitted with correct gas cylinder:</p> <p>The two lifejackets subjected to temperature cycling and the hot and cold inflation test should then be used for the fire test. One lifejacket should be inflated and one uninflated during the test.</p> <p>A test pan 30 cm x 35 cm x 6 cm should be placed in an essentially draught-free area. Water should be put into the bottom of the test pan to a depth of 1 cm followed by enough petrol to make a minimum total depth of 4 cm. The petrol should then be ignited and allowed to burn freely for 30 s. The two lifejackets, one inflated the other uninflated, should then be moved through the flames in an upright, forward, free-hanging position, with the bottom of the lifejacket 25 cm above the top edge of the test pan so that the duration of exposure to the flames is 2 s.</p>	<p>The two lifejackets should not sustain burning for more than 6 s or continue melting after being removed from the flame. The inflated lifejacket should not deflate as a result of passing through the flames.</p> <p>The inflated lifejacket should remain inflated after completing this test.</p>	<p>Size of pan _____ x _____ x _____ cm.</p> <p>1. Lifejacket No.1          Passed _____ Failed _____</p> <p>2. Lifejacket No.2          Passed _____ Failed _____</p> <p>Comments/Observations</p>



<b>Inflatable lifejackets (Adults &amp; Child)</b>	Manufacturer: _____ Model: _____ Lot/Serial Number: _____	Date: _____ Time: _____ Surveyor: _____ Organization: _____
<b>2.2.2.8 Oil resistance test</b>		<b>Regulations: LSA Code I/1.2.2.4; MSC.81(70) 1/2.4</b>
Test Procedure	Acceptance Criteria	Significant Test Data
<p>Two of the inflatable lifejackets should be subjected to the oil resistance test.</p> <p>The lifejacket should be immersed horizontally for a period of 24 h under 100 mm head of diesel oil at normal room temperature.</p>	<p>After this test the lifejacket should be examined externally and should show no sign of damage such as shrinking, cracking, swelling, dissolution or change of mechanical properties.</p>	<p>Condition of Lifejacket No.1 after 24 hours.</p> <p>Passed _____ Failed _____</p> <p>Condition of Lifejacket No.2 after 24 hours.</p> <p>Passed _____ Failed _____</p> <p>Comments/Observations</p>

<b>Inflatable lifejackets (Adults &amp; Child)</b>	Manufacturer: _____ Model: _____ Lot/Serial Number: _____	Date: _____ Time: _____ Surveyor: _____ Organization: _____
<b>2.2.2.9 Tests of materials for inflatable bladders, inflation systems and components</b>		<b>Regulations: LSA Code I/1.2.2.1, 1.2.2.4 &amp; 1.2.2.5; MSC.81(70) 1/2.4, 2.10.4 - 2.10.4.1</b>
<b>Test Procedure</b>	<b>Acceptance Criteria</b>	<b>Significant Test Data</b>
<p>All the materials used in the construction of the lifejacket, including the cover, tapes, seams and closures, inflatable bladders, inflation systems &amp; components should be tested to establish that they are:</p> <ul style="list-style-type: none"> <li>.1 rot – proof,</li> <li>.2 colour-fast; and</li> <li>.3 resistant to deterioration from exposure to sunlight, and that they are not unduly affected by</li> <li>.4 seawater;</li> <li>.5 oil; or</li> <li>.6 fungal attack</li> </ul>	<p>The results should be acceptable to the International Organization for Standardization, in particular publication ISO 12402-7:2006 Personal flotation devices – Part 7: Materials and components – Safety requirements and test methods.</p> <p>The results should be acceptable to the International Organization for Standardization, in particular publication ISO 12402-7:2006 Personal flotation devices – Part 7: Materials and components – Safety requirements and test methods.</p>	<p>Tests: (Specify _____)</p> <p><u>Cover:</u>    <u>Tapes:</u>    <u>Seams:</u>    <u>Additional</u></p>

<b>Inflatable lifejackets (Adults &amp; Child)</b>	Manufacturer: _____ Model: _____ Lot/Serial Number: _____	Date: _____ Time: _____ Surveyor: _____ Organization: _____
<b>2.2.2.9.1 Coated fabrics test</b>		<b>Regulations: LSA Code I/1.2.2.1, 1.2.2.4 &amp; 1.2.2.5; MSC.81(70) 1/2.10.4.1.1-4</b>
Test Procedure	Acceptance Criteria	Significant Test Data
<p>Coated fabrics used in the construction of inflatable buoyancy chambers should comply with the following requirements:</p> <ol style="list-style-type: none"> <li>1. Coating adhesion should be tested in accordance with ISO 2411:2000 using the method described at paragraph 5.1 at 100mm/min</li> <li>2. coating adhesion should be tested when wet following ageing according to ISO 188:2007 with an exposure of 336 ± 0.5 h in fresh water at (70.0 ± 1.0) °C following which the method at ISO 2411:2000, paragraph 5.1 should be applied at 100mm/min.</li> <li>3. tear strength should be tested in accordance with ISO 4674-1:2003 and ISO 4674-2:1998 using method A1.</li> <li>4. resistance to flex cracking should be tested in accordance with ISO 7854:1995 method A using 9000 flex cycles.</li> </ol>	<ol style="list-style-type: none"> <li>(1) After being tested according to ISO 2411:2000, the coating adhesion should not be less than 50 N per 50 mm width.</li> <li>(2) After being tested according to ISO 188:2007, the coating adhesion when wet should not be less than 40 N per 50 mm width.</li> <li>(3) After being tested according to ISO 4674-1:2003 and ISO 4674-2:1998, method A1, the tear strength should not be less than 35 N.</li> <li>(4) After being tested according to ISO 7854:1995, method A there should be no visible cracking or deterioration.</li> </ol>	<ol style="list-style-type: none"> <li>1. Coating Adhesion (dry) - Test Results in the :            Warp _____N, Weft _____N            Passed _____ Failed</li> <li>2. Coating Adhesion (wet) - Test Results in the :            Warp _____N, Weft _____N            Passed _____ Failed</li> <li>3. Tear strength: _____N            Passed _____ Failed</li> <li>4. Flexure Test:            Passed _____ Failed</li> </ol> <p>Comments/Observations</p>

<b>Inflatable lifejackets (Adults &amp; Child)</b>	Manufacturer: _____ Model: _____ Lot/Serial Number: _____	Date: _____ Time: _____ Surveyor: _____ Organization: _____
<b>2.2.2.9.1 Coated fabric test (continued)</b>		<b>Regulations: LSA Code I/1.2.2.1, 1.2.2.4 &amp; 1.2.2.5; MSC.81(70) 1/2.10.4.1.5-8</b>
Test Procedure	Acceptance Criteria	Significant Test Data
<p>5. breaking strength should be tested in accordance with ISO 1421:1998 using the CRE or CRT method, following conditioning for 24 ± 0.5 h at room temperature and should not be less than 200 N per 50 mm width.</p> <p>6. breaking strength should be tested in accordance with ISO 1421:1998 using the CRE or CRT method, following conditioning immersed in fresh water for 24 ± 0.5 h at room temperature and should not be less than 200 N per 50 mm width.</p> <p>7. elongation to break should be tested in accordance with ISO 1421:1998 using the CRE or CRT method following conditioning at room temperature for 24 ± 0.5 h.</p> <p>8. elongation to break should be tested in accordance with ISO 1421:1998 using the CRE or CRT method following conditioning immersed in fresh water at room temperature for 24 ± 0.5 h.</p>	<p>(5) After being tested according to ISO 1421:1998, the breaking strength should not be less than 200 N per 50 mm width.</p> <p>(6) After being tested according to ISO 1421:1998, the breaking strength when wet should not be less than 200 N per 50 mm width.</p> <p>(7) After being tested according to ISO 1421:1998, in room temperature the elongation to break should not exceed 60%.</p> <p>(8) After being tested according to ISO 1421:1998, in fresh water at room temperature the elongation to break should not exceed 60%.</p>	<p>5. Break Strength (dry). _____ N:          Passed _____ Failed _____</p> <p>6. Break Strength (wet). _____ N:          Passed _____ Failed _____</p> <p>7. Elongation (dry) _____ %:          Passed _____ Failed _____</p> <p>8. Elongation (wet) _____ %:          Passed _____ Failed _____</p> <p>Comments/Observations</p>

<b>Inflatable lifejackets (Adults &amp; Child)</b>	Manufacturer: _____ Model: _____ Lot/Serial Number: _____	Date: _____ Time: _____ Surveyor: _____ Organization: _____
<b>2.2.2.9.1 Coated fabric test (continued)</b>		<b>Regulations: LSA Code I/1.2.2.1, 1.2.2.1.4 &amp; 1.2.2.1.5; MSC.81(70) 1/2.10.4.1.9-11</b>
Test Procedure	Acceptance Criteria	Significant Test Data
<p>9. the resistance to exposure to light when tested in accordance with ISO 105-B02: 2013.</p> <p>10. the resistance to wet and dry rubbing when tested in accordance with ISO 105-X12: 2001.</p> <p>11. the resistance to seawater should not be less than class 4 in accordance with ISO 105 EO2: 1994.</p>	<p>(9) After being exposed to light when tested in accordance with ISO 105 – B02:2013, the contrast between the unexposed and exposed samples should not be less than class 5.</p> <p>(10) After being wet and dry rubbed in accordance with ISO 105- X12:2001, the staining of the rubbed samples should not be less than class 3.</p> <p>(11) After being tested in accordance with ISO 105 EO2:1994, the change in colour of the specimen should not less than class 4.</p>	<p>9. Accelerated light test</p> <p>Class Passed _____ Failed _____</p> <p>10. Wet staining after rubbing</p> <p>Class . Passed _____ Failed _____</p> <p>11. Dry staining after rubbing</p> <p>Class . Passed _____ Failed _____</p> <p>Comments/Observations</p>



<b>Inflatable lifejackets (Adults &amp; Child)</b>	Manufacturer: _____ Model: _____ Lot/Serial Number: _____	Date: _____ Time: _____ Surveyor: _____ Organization: _____
<b>2.2.2.9.3 Pressure test (1)</b>		<b>Regulations: LSA Code II/2.2.2.2; MSC.81(70) 1/2.10.4.3.1</b>
Test Procedure	Acceptance Criteria	Significant Test Data
<p>Overpressure test</p> <p>The inflatable buoyancy chambers should be capable of withstanding an internal over pressure at ambient temperature. All chambers of a lifejacket should be inflated using the manual method of inflation, after inflation the relief valves should be disabled and a fully charged gas cylinder according to the manufacturers recommendation should be fitted to the same inflation device and fired. All fully charged gas cylinders used in this test should be sized according to the markings on lifejacket.</p>	<p>The lifejacket should remain intact and should hold its pressure for 30 minutes.</p> <p>The lifejackets should show no signs of damage such as cracking, swelling or changes of mechanical qualities and that there has been no significant damage to the lifejacket inflation component.</p>	<ol style="list-style-type: none"> <li>1. Double charge test. Size of gas bottle _____ grams. Duration of test _____ min.</li> <li>2. <b>Chamber 1</b> - Pressure at the beginning of the test and after 30 min.  _____ at the beginning _____ after 30 min</li> <li>3. <b>Chamber 2</b> - Pressure at the beginning of the test and after 30 min.  _____ at the beginning _____ after 30 min</li> <li>4. <b>Chambers 3</b>- Pressure at the beginning of the test and after 30 min.  _____ at the beginning _____ after 30 min</li> <li>5. <b>Chamber 4</b> - Pressure at the beginning of the test and after 30 min. _____ at the beginning _____ after 30 min</li> <li>6. Damage to lifejacket Passed _____ Failed _____</li> </ol> <p>Comments/Observations</p>

<b>Inflatable lifejackets (Adults &amp; Child)</b>	Manufacturer: _____ Model: _____ Lot/Serial Number: _____	Date: _____ Time: _____ Surveyor: _____ Organization: _____
<b>2.2.2.9.3 Pressure test (2)</b>		<b>Regulations: LSA Code; MSC.81(70) 1/2.10.4.3.2</b>
Test Procedure	Acceptance Criteria	Significant Test Data
<p>Relief valve test</p> <p>With one buoyancy chamber inflated, the operating head on the opposite buoyancy chamber should be fired manually, using a fully charged gas cylinder according to the manufacturer's recommendations. The operation of the relief valves should be noted to ensure that the excess pressure is relieved.</p>	<p>The lifejacket should remain intact and should hold its pressure for 30 minutes.</p> <p>The lifejackets should show no signs of damage such as cracking, swelling or changes of mechanical qualities and that there has been no significant damage to the lifejacket inflation component.</p>	<p>1.       <b>Chamber 1</b> Size of gas bottle _____ grams.</p> <p>Pressure at the beginning of the test and after 30 min.           _____ at the beginning           _____ after 30 min.</p> <p>2.       Relief valve operation. Passed _____                      Failed _____</p> <p>3.       Damage to lifejacket Passed _____                      Failed _____</p> <p>4.       <b>Chamber 2</b> Size of gas bottle _____ grams.</p> <p>Pressure at the beginning of the test and after 30 min.           _____ at the beginning           _____ after 30 min.</p> <p>5.       Relief valve operation. Passed _____                      Failed _____</p> <p>6.       Damage to lifejacket Passed _____                      Failed _____</p> <p>Comments/Observations</p>



2.2.2.9.3 Pressure test (2) Continued	Regulations: LSA Code; MSC.81(70) 1/2.10.4.4.2	
Test Procedure	Acceptance Criteria	Significant Test Data
		<p>7. <b>Chamber 3</b> Size of gas bottle _____ grams.</p> <p>Pressure at the beginning of the test and after 30 min. _____ at the beginning _____ after 30 min.</p> <p>8. Relief valve operation. Passed _____ Failed</p> <p>9. Damage to lifejacket Passed _____ Failed</p> <p>10. <b>Chamber 4</b> Size of gas bottle _____ grams.</p> <p>Pressure at the beginning of the test and after 30 min. _____ at the beginning _____ after 30 min.</p> <p>11. Relief valve operation. Passed _____ Failed</p> <p>12. Damage to lifejacket Passed _____ Failed</p> <p>Pressure after the test in each chamber: Chamber 1: Chamber 2: Chamber 3: Chamber 4:</p> <p>Comments/Observations</p>

<b>Inflatable lifejackets (Adults &amp; Child)</b>	Manufacturer: _____ Model: _____ Lot/Serial Number: _____	Date: _____ Time: _____ Surveyor: _____ Organization: _____
<b>2.2.2.9.3 Pressure test (3)</b>		<b>Regulations: LSA Code; MSC.81(70) 1/2.10.4.3.3</b>
Test Procedure	Acceptance Criteria	Significant Test Data
<p>Air retention test</p> <p>One inflation chamber of a lifejacket is filled with air until air escapes from the over-pressure valve or, if the lifejacket does not have an over-pressure valve, until its design pressure, as stated in the plans and specifications, is reached. This test is then repeated as many times as necessary to test a different chamber until each chamber has been tested in this manner.</p> <p>The pressure release valve should be settled when the measurement starts.</p>	<p>After 12 h the drop in pressure should not be greater than 10%.</p>	<p>1. <b>Air retention test Chamber 1:</b> Passed _____ Failed _____</p> <p>2. Pressure at the beginning of the test and after 12 h. _____ at the beginning _____ after 12 h _____ % drop</p> <p>1. <b>Air retention test Chamber 2:</b> Passed _____ Failed _____</p> <p>2. Pressure at the beginning of the test and after 12 h. _____ at the beginning _____ after 12 h _____ % drop</p> <p>1. <b>Air retention test Chamber 3:</b> Passed _____ Failed _____</p> <p>2. Pressure at the beginning of the test and after 12 h. _____ at the beginning _____ after 12 h _____ % drop</p> <p>1. <b>Air retention test Chamber 4:</b> Passed _____ Failed _____</p> <p>2. Pressure at the beginning of the test and after 12 h. _____ at the beginning _____ after 12 h _____ % drop</p> <p>Comments/Observations</p>

<b>Inflatable lifejackets (Adults &amp; Child)</b>	Manufacturer: _____ Model: _____ Lot/Serial Number: _____	Date: _____ Time: _____ Surveyor: _____ Organization: _____
<b>2.2.2.9.4 Compression test</b>		<b>Regulations: LSA Code; MSC.81(70) 1/2.10.4.4</b>
Test Procedure	Acceptance Criteria	Significant Test Data
<p>The inflatable lifejacket, packed in the normal manner, should be laid on a table. A bag containing 75 kg of sand and having a base of 320 mm diameter should be lowered onto the lifejacket from a height of 150 mm in a time of 1 s. This should be repeated ten times, after which the bag should remain on the jacket for not less than 3 hours.</p>	<p>The lifejacket should be inflated by immersion into water and should inflate fully, the jacket to be inspected to ensure that no swelling or change of mechanical properties has occurred, the jacket should be checked for leaks</p>	<p>Weight of sand bag _____ Kg. Area of sand bag _____ mm Drop Height _____ mm Drop Time _____ sec No. of Drops _____ Length of test _____ hr.</p> <p>Passed _____ Failed _____</p> <p>Comments/Observations</p>
<b>2.2.2.9.5 Test of metallic components</b>		<b>Regulations: LSA Code; MSC.81(70) 1/2.10.4.5</b>
Test Procedure	Acceptance Criteria	Significant Test Data
<p>Metal parts and components of a lifejacket should be corrosion resistant to seawater and should be tested in accordance with ISO 9227:2006 for a period of 96 h.</p> <p>Metal components should not affect a magnetic compass of a type used in small boats by more than 5°, when placed at a distance of 500 mm from it.</p>	<p>The metal components should be inspected and should not be significantly affected by corrosion, or affect any other parts of the lifejacket and should not impair the performance of the lifejacket.</p> <p>The lifejacket should not affect the magnetic compass by more than 5°.</p>	<p>1. Corrosion Test on Components. Passed _____ Failed _____</p> <p>2. Magnetic Test on Components. Passed _____ Failed _____</p> <p>Comments/Observations</p>

<b>Inflatable lifejackets (Adults &amp; Child)</b>	Manufacturer: _____ Model: _____ Lot/Serial Number: _____	Date: _____ Time: _____ Surveyor: _____ Organization: _____
--	---	---

<b>2.2.2.9.6 Inadvertent inflation test</b>	<b>Regulations: LSA Code; MSC.81(70) 1/2.10.4.6</b>
---	---

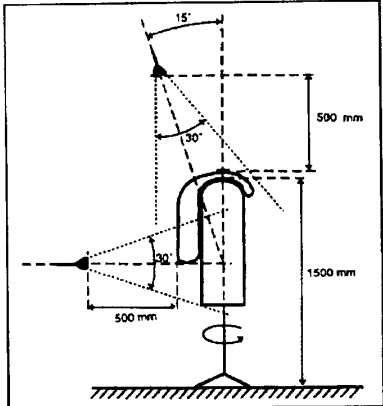
Test Procedure	Acceptance Criteria	Significant Test Data
<p>The resistance of an automatic inflation device to inadvertent operation should be assessed by exposing the entire lifejacket to sprays of water for fixed period.</p> <p>The lifejacket should be fitted correctly to a free standing manikin of adult size, with a minimum shoulder height of 1500 mm (see figure 5), or alternatively to an appropriately sized form as shown in figure 2. The lifejacket should be deployed in the mode in which it is worn ready for use but not deployed as used in the water (i.e. if it is equipped with a cover which is normally worn closed, then the cover should be closed for the test).</p> <p>Two sprays should be installed so as to spray fresh water onto the lifejacket, as shown in the diagram. One should be positioned 500 mm above the highest point of the lifejacket, and at an angle of 15° from the vertical centre line of the manikin and the bottom line of the lifejacket. The other nozzle should be installed horizontally at a distance of 500 mm from the bottom line of the lifejacket, and be pointed directly at the lifejacket. These nozzles should have a spray cone of 30°, each orifice being 1.5 ± 0.1 mm in diameter, and the total area of the orifice should be 50 ± 5 mm<sup>2</sup>, the orifice being evenly spread over the spray nozzle area.</p>	 <p>Test set-up for test of automatic inflation system</p> <p>Figure 5-Test Set-up</p>	<p>1. Inadvertent Inflation.</p> <p>Passed _____ Failed _____</p> <p>2. Auto inflation test.</p> <p>Auto inflation system operable.</p> <p>Passed _____ Failed _____</p> <p>Comments/Observations</p>

<b>Inflatable lifejackets (Adults &amp; Child)</b>	Manufacturer: _____ Model: _____ Lot/Serial Number: _____	Date: _____ Time: _____ Surveyor: _____ Organization: _____																																								
<b>2.2.2.9.6 Inadvertent inflation test (continued)</b>		<b>Regulations: LSA Code; MSC.81(70) 1/2.10.4.6</b>																																								
Test Procedure	Acceptance Criteria	Significant Test Data																																								
<p>The air temperature should be 20°C, and water should be supplied to the spray nozzles at a flow of 600 l/h, and at a temperature of 18°C to 20°C.</p> <p>The sprays should be turned on, and the lifejacket should be exposed to the following series of test to assess the ability of the jacket to resist inadvertent inflation:</p> <ol style="list-style-type: none"> <li>.1 5 minutes with the high spray on the front of the lifejacket;</li> <li>.2 5 minutes with the high spray on the left side of the lifejacket;</li> <li>.3 5 minutes with the high spray on the back of the lifejacket; and</li> <li>.4 5 minutes with the high spray on the right side of the lifejacket.</li> </ol> <p>During exposures .1, .2 and .4 the horizontal spray should be applied for 10 periods of 3 sec each to the front, left or right sides (but not back) as with the high spray.</p>	<p>The lifejacket should not inflate during the test</p> <p>After completing this test, the lifejacket should be immersed in water to verify that the auto-inflation system is working.</p> <div style="text-align: center;">  </div> <p>Figure – Alternative form</p>	<ol style="list-style-type: none"> <li>1. Inadvertent Inflation. Passed _____ Failed _____</li> <li>2. Auto inflation test. Auto inflation system operable. Time to inflate: _____ sec. Passed _____ Failed _____</li> </ol> <p>Comments/Observations</p>  <p>Figure Dimensions:</p> <table border="1" style="width:100%; border-collapse: collapse;"> <thead> <tr> <th>Size</th> <th>A</th> <th>B</th> <th>C</th> <th>D</th> <th>E</th> <th>F</th> <th>G</th> <th>H</th> <th>J</th> </tr> </thead> <tbody> <tr> <td>Adult</td> <td>610</td> <td>114</td> <td>76,2</td> <td>127</td> <td>381</td> <td>432</td> <td>508</td> <td>25,4</td> <td>178</td> </tr> <tr> <td>Child</td> <td>508</td> <td>102</td> <td>76,2</td> <td>102</td> <td>279</td> <td>330</td> <td>406</td> <td>22,2</td> <td>152</td> </tr> <tr> <td>Infant</td> <td>305</td> <td>63,5</td> <td>38,1</td> <td>63,5</td> <td>191</td> <td>203</td> <td>241</td> <td>19,1</td> <td>76,2</td> </tr> </tbody> </table>	Size	A	B	C	D	E	F	G	H	J	Adult	610	114	76,2	127	381	432	508	25,4	178	Child	508	102	76,2	102	279	330	406	22,2	152	Infant	305	63,5	38,1	63,5	191	203	241	19,1	76,2
Size	A	B	C	D	E	F	G	H	J																																	
Adult	610	114	76,2	127	381	432	508	25,4	178																																	
Child	508	102	76,2	102	279	330	406	22,2	152																																	
Infant	305	63,5	38,1	63,5	191	203	241	19,1	76,2																																	

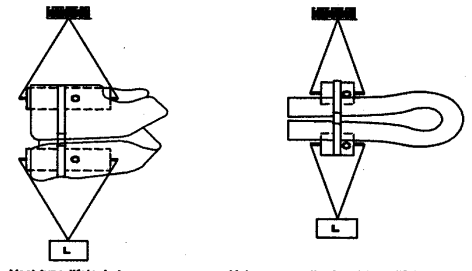
<b>Inflatable lifejackets (Adults &amp; Child)</b>	Manufacturer: _____ Model: _____ Lot/Serial Number: _____	Date: _____ Time: _____ Surveyor: _____ Organization: _____															
<b>2.2.2.10 Strength tests - Body or lifting loop strength test</b>		<b>Regulations: LSA Code; MSC.81(70) 1/2.5.1, 2.10.1.1</b>															
<b>Test Procedure</b>	<b>Acceptance Criteria</b>	<b>Significant Test Data</b>															
<p>The lifejacket should be immersed in water for a period of 2 min. It should then be removed from the water and closed in the same manner as when it is worn by a person. A force of not less than 3,200 N (2,400 N in the case of a child or infant-size lifejacket) should be applied for 30 min to the part of the lifejacket that secures it to the body of the wearer (see figure) and separately to the lifting loop of the lifejacket.</p> <p>The test should be repeated for each encircling closure.</p> <p>The two lifejackets subjected to temperature cycling and the hot and cold inflation test should then be used for the strength test.</p>	<p>The lifejacket or lifting loop should not be damaged as a result of this test.</p> <div style="text-align: center;">  <p style="font-size: small; margin: 0;">Vest-type lifejacket      Yoke or over-the-head-type lifejacket</p> </div> <p>Vest-type lifejacket    Yoke or over-the-head type lifejacket</p> <p>Body strength test arrangement for lifejackets</p> <p style="margin-left: 20px;">C - Cylinder    125 mm diameter for adult sizes                           50 mm diameter for infant and child-sizes</p> <p style="margin-left: 20px;">L - Test load</p>	<table style="width:100%; border: none;"> <tr> <td style="width: 60%;"></td> <td style="width: 20%; text-align: center;">Body strap</td> <td style="width: 20%; text-align: center;">Lifting loop</td> </tr> <tr> <td>Force applied:</td> <td style="text-align: center;">_____</td> <td style="text-align: center;">_____</td> </tr> <tr> <td>Time:</td> <td style="text-align: center;">_____</td> <td style="text-align: center;">_____</td> </tr> <tr> <td>Slippage:</td> <td style="text-align: center;">_____</td> <td style="text-align: center;">_____</td> </tr> <tr> <td>Closure(s) tested:</td> <td colspan="2" style="text-align: center;">_____</td> </tr> </table> <p>Illustration of lifejacket lifting loop test arrangement if tested:</p>  <p>Test results</p> <p>Closure system:            Passed _____ Failed _____</p> <p>Lifting loop:                Passed _____ Failed _____</p>		Body strap	Lifting loop	Force applied:	_____	_____	Time:	_____	_____	Slippage:	_____	_____	Closure(s) tested:	_____	
	Body strap	Lifting loop															
Force applied:	_____	_____															
Time:	_____	_____															
Slippage:	_____	_____															
Closure(s) tested:	_____																

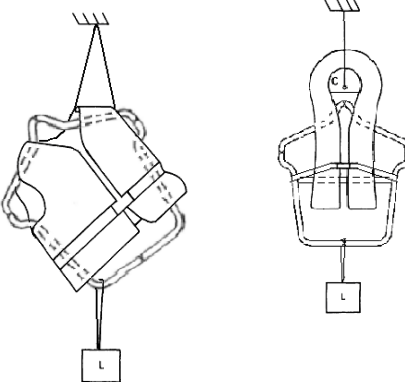
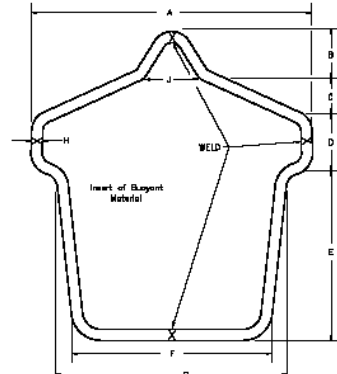
<b>Inflatable lifejackets (Adults &amp; Child)</b>	Manufacturer: _____ Model: _____ Lot/Serial Number: _____	Date: _____ Time: _____ Surveyor: _____ Organization: _____																																									
<b>2.2.2.11 Strength tests - Shoulder lift test</b>		<b>Regulations: LSA Code; MSC.81(70) 1/2.5.2, 2.10.1.1</b>																																									
<b>Test Procedure</b>		<b>Acceptance Criteria</b>	<b>Significant Test Data</b>																																								
<p>Two inflatable lifejackets subjected to the tests in 2.2.2.5, 2.2.2.6, 2.2.2.7, 2.2.2.8 and 2.2.2.10 above should be subjected to the shoulder strength test.</p> <p>The lifejacket should be immersed in water for a period of 2 min. It should then be removed from the water and closed on a form as shown in figure 2 in the same manner as when it is worn by a person. A force of not less than 900 N (700 N in the case of a child or infant-size lifejacket) should be applied for 30 min across the form and the shoulder section of the lifejacket. (see figure).</p>		<p>The lifejacket should not be damaged as a result of this test.</p> <p>The lifejacket should remain secured on the form during this test.</p>	<p>Force applied _____N</p> <p>Time force applied _____min</p> <p>Sign of damage</p> <p>Passed _____ Failed _____</p>																																								
			<p>Comments/Observations</p>																																								
<p>Vest-type lifejacket      Yoke or over-the-head-type lifejacket</p> <p>Figure - Shoulder lift test arrangement for lifejackets</p> <p>C- Cylinder; 125mm diameter for adult sizes 50mm diameter for infant and child sizes</p> <p>L- Test load</p>		<p>Dimensions in mm</p> <p>Figure 2 – Test form for shoulder lift test for lifejackets</p>	<table border="1"> <thead> <tr> <th>Size</th> <th>A</th> <th>B</th> <th>C</th> <th>D</th> <th>E</th> <th>F</th> <th>G</th> <th>H</th> <th>J</th> </tr> </thead> <tbody> <tr> <td>Adult</td> <td>610</td> <td>114</td> <td>76,2</td> <td>127</td> <td>381</td> <td>432</td> <td>508</td> <td>25,4</td> <td>178</td> </tr> <tr> <td>Child</td> <td>508</td> <td>102</td> <td>76,2</td> <td>102</td> <td>279</td> <td>330</td> <td>406</td> <td>22,2</td> <td>152</td> </tr> <tr> <td>Infant</td> <td>305</td> <td>63,5</td> <td>38,1</td> <td>63,5</td> <td>191</td> <td>203</td> <td>241</td> <td>19,1</td> <td>76,2</td> </tr> </tbody> </table>	Size	A	B	C	D	E	F	G	H	J	Adult	610	114	76,2	127	381	432	508	25,4	178	Child	508	102	76,2	102	279	330	406	22,2	152	Infant	305	63,5	38,1	63,5	191	203	241	19,1	76,2
Size	A	B	C	D	E	F	G	H	J																																		
Adult	610	114	76,2	127	381	432	508	25,4	178																																		
Child	508	102	76,2	102	279	330	406	22,2	152																																		
Infant	305	63,5	38,1	63,5	191	203	241	19,1	76,2																																		

<b>Inflatable lifejackets (Adults &amp; Child)</b>	Manufacturer: _____ Model: _____ Lot/Serial Number: _____	Date: _____ Time: _____ Surveyor: _____ Organization: _____											
<b>2.2.2.12 Donning Test (Uninflated situation)</b>		<b>Regulations: LSA Code II/2.2.1.5; MSC.81(70) 1/2.7.1 to 2.7.4.3, 2.10.2</b>											
Test Procedure	Acceptance Criteria	Significant Test Data											
<p>To minimize the risk of incorrect donning by uninitiated persons, often in adverse conditions, lifejackets should be examined for the following features and tested as follows:</p> <p>The test should be carried out with at least 12 able-bodied persons who are completely unfamiliar with the lifejacket and selected according to the heights and weights in table 2.1 and the following:</p> <ol style="list-style-type: none"> <li>.1 small test subjects need not be adults;</li> <li>.2 at least 1/3, but not more than 1/2 of test subjects should be females, including at least 1 per height category but excluding the tallest height;</li> <li>.3 at least one male should be from the lowest and highest weight group and one female should be from the lowest weight group and one female should be more than 80 kg and 1.8 m;</li> <li>.4 at least one subject should be selected from each cell containing a "1"; and</li> <li>.5 enough additional subjects should be selected from cells containing a "X" to total the required number of test subjects, with no more than one subject per cell. A uniform distribution across weight ranges should be maintained.</li> </ol>	<p>Fastenings necessary for proper performance should be few and simple and provide quick and positive closure that does not require tying of knots.</p> <p>Adult lifejackets should readily fit various sizes of adults, both lightly and heavily clad. All lifejackets should be capable of being worn inside-out, or clearly in only one way.</p>	Comments/Observations:											
		1	2	3	4	5	6	7	8	9	10	11	12
		SEX (M/F)	HEIGHT (m)	WEIGHT (kg)	Good Swimmer? (Yes/No)								
		Test subject selection for adult lifejackets											
Weight range - kg													
Ht range (m)	40 -43	43 - 60	60 -70	70 - 80	80 - 100	100 - 110	110 - 120	> 120					
< 1,5	1	X	X	X									
1,5 - 1,6	X	1	1	X	X								
1,6 - 1,7		X	X	1	X	X							
1,7 -,1,8			X	X	1	X	X	X					
1,8 - 1,9			X	X	X	1	1	X					
> 1,9					X	X	X	1					



<b>Inflatable lifejackets (Adults &amp; Child)</b>	Manufacturer: _____ Model: _____ Lot/Serial Number: _____	Date: _____ Time: _____ Surveyor: _____ Organization: _____
<b>2.2.2.12 Donning Test (Uninflated situation)</b>		<b>Regulations: LSA Code II/2.2.1.5; MSC.81(70) 1/2.7.1 to 2.7.4.3, 2.10.2</b>
<p>Clothing</p> <p>Each test subject should be tested wearing the clothing specified for the test and appropriate to their size, as follows:</p> <p>.1 <i>Normal clothing</i> means normal indoor clothing, which would not normally interfere with the donning of a lifejacket;</p> <p>.2 <i>Heavy-weather clothing</i> means the attire appropriate for a hostile environment, including a hooded arctic parka and warm cotton gloves.</p> <p>Each test should be timed from when the order is given until the test subject declares that donning is complete.</p> <p><i>Test without instruction</i></p> <p>The test subjects may be tested individually or as a group. Wearing normal clothing, the first attempt should be with no assistance, guidance or prior demonstration. The lifejacket, with closures in the stored condition, should be placed on the floor, face up, in front of the test subject. The instruction provided should be identical for each subject and should be equivalent to the following: "PLEASE DON THIS LIFEJACKET AS QUICKLY AS POSSIBLE AND ADJUST IT TO A SNUG FIT SO YOU CAN ABANDON SHIP."</p>	<p>For assessment purposes donning is considered complete when the subject has donned and securely adjusted all methods of securing the lifejacket to the extent needed to meet the in - water performance requirements, including inflation, if needed.</p> <p>The lifejacket should be capable of being donned by at least 75 % of the subjects, and within 1 minute.</p> <p>If a subject dons the lifejacket substantially correctly but fails to secure and/or adjust all closures, the jump test in 2.8.8 of MSC.81(70) and in-water performance tests in 2.8.5 of MSC.81(70) and 2.8.6 of MSC.81(70) should be performed with the lifejacket as donned to establish whether the performance is acceptable and the donning is successful.</p> <p>Each subject should correctly don the lifejacket within a period of 1 min.</p> <p>Each subject should don the lifejacket correctly within a period of 1 min.</p>	<p>See following page for test data</p> <p>Total number of subjects: _____</p> <p># of subjects successful: _____</p> <p># of subjects successful: _____</p> <p>Pass / Fail</p> <p>Pass / Fail</p>

<b>Inflatable lifejackets (Adults &amp; Child)</b>	Manufacturer: _____ Model: _____ Lot/Serial Number: _____	Date: _____ Time: _____ Surveyor: _____ Organization: _____
<b>2.2.2.12 Donning Test (Uninflated situation)</b>		<b>Regulations: LSA Code II/2.2.1.5; MSC.81(70) 1/2.7.1 to 2.7.4.3, 2.10.2</b>
<p><i>Test after instruction</i></p> <p>For each subject whose first attempt exceeds 1 min or is incomplete, after demonstration or instruction to familiarize the subject with the donning procedure, the test subject should then don the lifejacket without assistance while wearing normal clothing, using the same instruction and timing method as above.</p> <p><i>Heavy-weather clothing test</i></p> <p>Each subject should then don the lifejacket without assistance while wearing heavy-weather clothing, using the same instruction and timing method as above.</p>		

<b>Inflatable lifejackets (Adults &amp; Child)</b>	Manufacturer: _____ Model: _____ Lot/Serial Number: _____	Date: _____ Time: _____ Surveyor: _____ Organization: _____
<b>2.2.2.13 Donning Test (Inflated situation)</b>		<b>Regulations: LSA Code II/2.2.1.5; MSC.81(70) 1/2.7.1 to 2.7.4.3</b>
Test Procedure	Acceptance Criteria	Significant Test Data
<p>To minimize the risk of incorrect donning by uninitiated persons, often in adverse conditions, lifejackets should be examined for the following features and tested as follows:</p> <p>The test should be carried out with at least 12 able-bodied persons who are completely unfamiliar with the lifejacket and selected according to the heights and weights in table 2.1 and the following:</p> <ol style="list-style-type: none"> <li>.1 small test subjects need not be adults;</li> <li>.2 at least 1/3, but not more than 1/2 of test subjects should be females, including at least 1 per height category but excluding the tallest height;</li> <li>.3 at least one male should be from the lowest and highest weight group and one female should be from the lowest weight group and one female should be more than 80 kg and 1.8 m;</li> <li>.4 at least one subject should be selected from each cell containing a "1"; and</li> <li>.5 enough additional subjects should be selected from cells containing a "X" to total the required number of test subjects, with no more than one subject per cell. A uniform distribution across weight ranges should be maintained.</li> </ol>	<p>Fastenings necessary for proper performance should be few and simple and provide quick and positive closure that does not require tying of knots.</p> <p>Adult lifejackets should readily fit various sizes of adults, both lightly and heavily clad. All lifejackets should be capable of being worn inside-out, or clearly in only one way.</p>	

Test subject selection for adult lifejackets								
	Weight range - kg							
Ht range (m)	40 -43	43 - 60	60 -70	70 - 80	80 - 100	100 - 110	110 - 120	> 120
< 1,5	1	X	X	X				
1,5 - 1,6	X	1	1	X	X			
1,6 - 1,7		X	X	1	X	X		
1,7 -,1,8			X	X	1	X	X	X
1,8 - 1,9			X	X	X	1	1	X
> 1,9					X	X	X	1

Comments/Observations:

Subj	SEX (M/F)	HEIGHT (m)	WEIGHT (kg)	Good Swimmer? (Yes/No)
1				
2				
3				
4				
5				
6				
7				
8				
9				
10				
11				
12				

<b>Inflatable lifejackets (Adults &amp; Child)</b>	Manufacturer: _____ Model: _____ Lot/Serial Number: _____	Date: _____ Time: _____ Surveyor: _____ Organization: _____
<b>2.2.2.13 Donning test (Inflated situation) (Continued)</b>		<b>Regulations: LSA Code II/2.2.1.5; MSC.81(70) 1/2.7.1 to 2.7.4.3, 2.10.2</b>
<b>Test Procedure</b>	<b>Acceptance Criteria</b>	<b>Significant Test Data</b>
<p>Clothing</p> <p>Each test subject should be tested wearing the clothing specified for the test and appropriate to their size, as follows:</p> <p>.1 <i>Normal clothing</i> means normal indoor clothing, which would not normally interfere with the donning of a lifejacket;</p> <p>.2 <i>Heavy-weather clothing</i> means the attire appropriate for a hostile environment, including a hooded arctic parka and warm cotton gloves.</p> <p>Each test should be timed from when the order is given until the test subject declares that donning is complete.</p> <p><i>Test without instruction</i></p> <p>The test subjects may be tested individually or as a group. Wearing normal clothing, the first attempt should be with no assistance, guidance or prior demonstration. The lifejacket, with closures in the stored condition, should be placed on the floor, face up, in front of the test subject. The instruction provided should be identical for each subject and should be equivalent to the following: "PLEASE DON THIS LIFEJACKET AS QUICKLY AS POSSIBLE AND ADJUST IT TO A SNUG FIT SO YOU CAN ABANDON SHIP."</p>	<p>For assessment purposes donning is considered complete when the subject has donned and securely adjusted all methods of securing the lifejacket to the extent needed to meet the in - water performance requirements, including inflation, if needed.</p> <p>The lifejacket should be capable of being donned by at least 75 % of the subjects, and within 1 minute.</p>	<p>See following page for test data</p> <p>Total number of subjects: _____</p> <p># of subjects successful: _____</p> <p># of subjects successful: _____</p>

2.2.2.13 Donning test (Inflated situation) (Continued)	Regulations: LSA Code II/2.2.1.5; MSC.81(70) 1/2.7.1 to 2.7.4.3, 2.10.2	
Test Procedure	Acceptance Criteria	Significant Test Data
<p><i>Test after instruction</i></p> <p>For each subject whose first attempt exceeds 1 min or is incomplete, after demonstration or instruction to familiarize the subject with the donning procedure, the test subject should then don the lifejacket without assistance while wearing normal clothing, using the same instruction and timing method as above.</p> <p><i>Heavy-weather clothing test</i></p> <p>Each subject should then don the lifejacket without assistance while wearing heavy-weather clothing, using the same instruction and timing method as above.</p>	<p>If a subject dons the lifejacket substantially correctly but fails to secure and/or adjust all closures, the jump test in 2.8.8 of MSC.81(70) and in-water performance tests in 2.8.5 of MSC.81(70) and 2.8.6 of MSC.81(70) should be performed with the lifejacket as donned to establish whether the performance is acceptable and the donning is successful.</p> <p>Each subject should correctly don the lifejacket within a period of 1 min.</p> <p>Each subject should don the lifejacket correctly within a period of 1 min.</p>	<p>Pass / Fail</p> <p>Pass / Fail</p> <p>Pass / Fail</p>

<b>Inflatable lifejackets (Adults &amp; Child)</b>		Manufacturer: _____ Model: _____ Lot/Serial Number: _____				Date: _____ Time: _____ Surveyor: _____ Organization: _____						
<b>2.2.2.12 – 2.2.2.13 Donning Tests – Test Data</b>						<b>Regulations: LSA Code II/2.2.1.5 – 2.2.1.7; MSC.81(70) 1/2.7.1 to 2.7.4.3</b>						
	Uninflated situation					Inflated situation						
	Test without instruction				Test after instruction	Heavy weather clothing	Test without instruction				Test after instruction	Heavy weather clothing
Subj	Donning time (sec)	All closures secured? (Y/N)	Jump test (P/F)	In-water test (P/F)	Donning Time (sec)	Donning Time (sec)	Donning time (sec)	All closures secured? (Y/N)	Jump test (P/F)	In-water test (P/F)	Donning Time (sec)	Donning Time (sec)
1												
2												
3												
4												
5												
6												
7												
8												
9												
10												
11												
12												
						Comments/Observations:						

<b>Inflatable lifejackets (Adults &amp; Child)</b>	Manufacturer: _____ Model: _____ Lot/Serial Number: _____	Date: _____ Time: _____ Surveyor: _____ Organization: _____																																																							
<b>2.2.2.14 Water performance tests- Preparation for water performance tests</b>		<b>Regulations: LSA Code II/2.2.1.2.5 &amp; 2.2.1.3 – 2.2.1.4; MSC.81(70) 1/2.8 to 2.8.4, 2.10.3. Annex 1, MSC.1/Circ.1470</b>																																																							
Test Procedure	Acceptance Criteria	Significant Test Data																																																							
<p>This portion of the test is intended to determine the ability of the lifejacket to assist a helpless person or one in an exhausted or unconscious state and to show that the lifejacket does not unduly restrict movement.</p> <p>The in-water performance of a lifejacket is evaluated by comparison to the performance of a suitable size standard reference lifejacket, i.e. Reference Test Device (RTD) as specified in appendices 1 to 3.</p> <p>All tests should be carried out in fresh water under still conditions. Each test for a candidate lifejacket and the relevant RTD should be conducted on the same day.</p> <p>These tests should be carried out with at least 12 persons as mentioned in paragraph 2.2.1.15. Only good swimmers should be used, since the ability to relax in the water is rarely otherwise obtained.</p> <p>The test subjects should wear only swimming costumes.</p> <p>Each test subject should be made familiar with each of the tests in 2.2.2.15 and 2.2.2.16, particularly the requirements regarding relaxing and exhaling in the face-down position.</p> <p>The test subjects should don the lifejacket, unassisted, using only the instructions provided by the manufacturer. Prior to taking measurements, the proper fit, donning, and fastening of the RTD on the subject should be checked and corrected as necessary.</p>	<p>The RTD should be constructed and calibrated according to MSC.81(70), annex 1, and validated according to MSC.1/Circ.1470.</p>	<p>RTD Constructed by: _____ date: _____</p> <p>Validated by: _____ date: _____</p> <p>Calibrated by: _____ date: _____</p> <p>Test subjects same as in 2.2.2.12? If not, describe test subjects:</p> <table border="1" style="width:100%; border-collapse: collapse; margin-top: 10px;"> <thead> <tr> <th style="width:8%;">Subj</th> <th style="width:10%;">SEX (M/F)</th> <th style="width:10%;">HEIGHT (m)</th> <th style="width:10%;">WEIGHT (kg)</th> <th style="width:12%;">Good Swimmer? (Yes/No)</th> </tr> </thead> <tbody> <tr><td style="text-align: center;">1</td><td></td><td></td><td></td><td></td></tr> <tr><td style="text-align: center;">2</td><td></td><td></td><td></td><td></td></tr> <tr><td style="text-align: center;">3</td><td></td><td></td><td></td><td></td></tr> <tr><td style="text-align: center;">4</td><td></td><td></td><td></td><td></td></tr> <tr><td style="text-align: center;">5</td><td></td><td></td><td></td><td></td></tr> <tr><td style="text-align: center;">6</td><td></td><td></td><td></td><td></td></tr> <tr><td style="text-align: center;">7</td><td></td><td></td><td></td><td></td></tr> <tr><td style="text-align: center;">8</td><td></td><td></td><td></td><td></td></tr> <tr><td style="text-align: center;">9</td><td></td><td></td><td></td><td></td></tr> <tr><td style="text-align: center;">10</td><td></td><td></td><td></td><td></td></tr> </tbody> </table>	Subj	SEX (M/F)	HEIGHT (m)	WEIGHT (kg)	Good Swimmer? (Yes/No)	1					2					3					4					5					6					7					8					9					10				
Subj	SEX (M/F)	HEIGHT (m)	WEIGHT (kg)	Good Swimmer? (Yes/No)																																																					
1																																																									
2																																																									
3																																																									
4																																																									
5																																																									
6																																																									
7																																																									
8																																																									
9																																																									
10																																																									



2.2.2.14 Water performance tests- Preparation for water performance tests	Regulations: LSA Code II/2.2.1.2.5 & 2.2.1.3 – 2.2.1.4; MSC.81(70) 1/2.8 to 2.8.4, 2.10.3. Annex 1, MSC.1/Circ.1470				
Test Procedure	Acceptance Criteria	Significant Test Data			
After entering the water, care should be taken to ensure that there is no significant amount of air unintentionally trapped in the lifejacket or swimming costume.		11			
		12			



<b>Inflatable lifejackets (Adults &amp; Child)</b>	Manufacturer: _____ Model: _____ Lot/Serial Number: _____	Date: _____ Time: _____ Surveyor: _____ Organization: _____
--	---	---

**2.2.2.15 Water performance tests – Righting test** **Regulations: LSA Code II/ 2.2.1.3.2; MSC.81(70)1/ 2.8.5, 2.10.3**

Significant Test Data

Subj	CANDIDATE DEVICE TIME (sec) TRIAL (Automatic inflation)							CANDIDATE DEVICE TIME (sec) TRIAL (Manual inflation)							REFERENCE VEST TIME (sec) TRIAL							
	#1	#2	#3	#4	#5	#6	AVG *	#1	#2	#3	#4	#5	#6	AVG *	#1	#2	#3	#4	#5	#6	AVG *	
1																						
2																						
3																						
4																						
5																						
6																						
7																						
8																						
9																						
10																						
11																						
12																						
	<b>Average candidate turn time (sec):</b>							<b>Average candidate turn time (sec):</b>							<b>Average RTD turn time (sec):</b>							
	<b># of candidate no turns (NT):</b>							<b># of candidate no turns (NT):</b>							<b># of RTD no turns (NT):</b>							

(\* Delete highest and lowest value)  
 Average candidate turn time ≤ Average RTD turn time RTD +1s    Passed \_\_\_\_\_    Failed \_\_\_\_\_  
 # of candidate no turns (NT): ≤ # of RTD no turns (NT):            Passed \_\_\_\_\_    Failed \_\_\_\_\_  
 Comments/Observations:





<b>Inflatable lifejackets (Adults &amp; Child)</b>	Manufacturer: _____ Model: _____ Lot/Serial Number: _____	Date: _____ Time: _____ Surveyor: _____ Organization: _____												
<b>2.2.2.16 Water performance tests-Static balance measurements</b>		<b>Regulations: LSA Code II/2.2.2, 2.2.1.4; MSC.81(70) 1/ 2.8.6 and 2.8.7, 2.10.3</b>												
Test Procedure	Significant Test Data													
The test should be repeated with one compartment deflated until each compartment has been tested in the uninflated condition.	Automatic Inflation				Manual Inflation									
	Freeboard (mm)		Faceplane (deg)		Torso angle (deg)		Light	Freeboard (mm)		Faceplane (deg)		Torso angle (deg)		Light
	CLJ	RTD	CLJ	RTD	CLJ	RTD	Visible?	CLJ	RTD	CLJ	RTD	CLJ	RTD	Visible?
	1													
	2													
	3													
	4													
	5													
	6													
	7													
	8													
	9													
	10													
	11													
12														
Avg							XXXX							XXXX
CLJ – Candidate Lifejacket RTD – Reference Test Device														

<b>Inflatable lifejackets (Adults &amp; Child)</b>	Manufacturer: _____ Model: _____ Lot/Serial Number: _____	Date: _____ Time: _____ Surveyor: _____ Organization: _____
<b>2.2.2.17 Water performance tests – Jump and drop tests</b>		<b>Regulations: LSA Code II/ 2.2.1.5.6; MSC.81(70)1/2.8.8 and 2.8.9, 2.10.3</b>
Test Procedure	Acceptance Criteria	Significant Test Data
<p>Without readjusting the lifejacket, the test subject should jump vertically into the water, feet first, from a height of at least 1m while holding the arms over the head. Upon entering the water, the test subject should relax to simulate a state of utter exhaustion. The freeboard to the mouth should be recorded after the test subject comes to rest. The test should be repeated from a height of at least 4.5 m.</p> <p>When jumping into the water, the test subject should hold on to the lifejacket during water entry to avoid possible injury. Upon entering the water, the test subject should relax to simulate a state of utter exhaustion. The freeboard to the mouth should be recorded after the test subject comes to rest.</p> <p>The lifejacket and its attachments should be examined for any damage. If injury is believed likely from any jump or drop test, the lifejacket should be rejected or the test delayed until test from a lower height or with additional precautions demonstrate that the risk from the required test is acceptable.</p> <p>The test should be conducted using lifejackets that have been inflated both automatically and manually, and also with one of the compartments uninflated.</p>	<p>Following the jump and drop test, the lifejacket should:</p> <p>.1 surface the test subject in a face up position with an average freeboard for all the subjects of not less than the average determined for the RTD after the turning test in accordance with 2.2.2.16 minus 15 mm;</p> <p>.2 not be dislodged or cause harm to the test subject;</p> <p>.3 have no damage that would affect its in-water performance or buoyance; and</p> <p>.4 have no damage to its attachments.</p> <p><b>NOTE: JUMP TESTS SHOULD NOT BE REPEATED IN THE RTD.</b></p>	<p>See following page for test data</p> <p>1 m Jump</p> <p>Average freeboard, all subjects: _____ mm (A)          Average freeboard for RTD (from 2.2.2.16) : _____ mm (B)          (B) – (A)= _____ ≤ 15 mm Pass / Fail</p> <p>Did the lifejacket become dislodged or cause harm to the test subject?: Yes / No</p> <p>Did the lifejacket have damage that would affect its in-water performance or buoyance?: Yes / No</p> <p>Did the lifejacket have damage to its attachments?: Yes / No</p> <p>4.5 m Jump</p> <p>Average freeboard, all subjects: _____ mm (A)          Average freeboard for RTD (from 2.2.2.16) : _____ mm (B)          (B) – (A)= _____ ≤ 15 mm Pass / Fail</p> <p>Did the lifejacket become dislodged or cause harm to the test subject?: Yes / No</p> <p>Did the lifejacket have damage that would affect its in-water performance or buoyance?: Yes / No</p> <p>Did the lifejacket have damage to its attachments?: Yes / No</p> <p>Comments/Observations</p>

<b>Inflatable lifejackets (Adults &amp; Child)</b>	Manufacturer: _____ Model: _____ Lot/Serial Number: _____	Date: _____ Time: _____ Surveyor: _____ Organization: _____				
<b>2.2.2.17 Water performance tests – Jump and drop tests</b>		<b>Regulations: LSA Code II/ 2.2.1.5.6; MSC.81(70)1/2.8.8 and 2.8.9, 2.10.3</b>				
<b>TEST DATA SHEET (1 m Jump)</b>						
Subj	Subject surfaced faceup? (Yes/No)	Freeboard (mm)	Lifejacket became dislodged (Yes/No)	Subject was harmed? (Yes/No)	Damage to lifejacket or attachments (Yes/No)	Comments/ Observations
1						
2						
3						
4						
5						
6						
7						
8						
9						
10						
11						
12						



<b>Inflatable lifejackets (Adults &amp; Child)</b>	Manufacturer: _____ Model: _____ Lot/Serial Number: _____	Date: _____ Time: _____ Surveyor: _____ Organization: _____				
<b>2.2.2.17 Water performance tests – Jump and drop tests</b>		<b>Regulations: LSA Code II/ 2.2.1.5.6; MSC.81(70)1/2.8.8 and 2.8.9, 2.10.3</b>				
<b>TEST DATA SHEET (4.5 m Jump)</b>						
Subj	Subject surfaced faceup? (Yes/No)	Freeboard (mm)	Lifejacket became dislodged (Yes/No)	Subject was harmed? (Yes/No)	Damage to lifejacket or attachments (Yes/No)	Comments/Observations
1						
2						
3						
4						
5						
6						
7						
8						
9						
10						
11						
12						

<b>Inflatable lifejackets (Adults &amp; Child)</b>	Manufacturer: _____ Model: _____ Lot/Serial Number: _____	Date: _____ Time: _____ Surveyor: _____ Organization: _____																																																																																																																																														
<b>2.2.2.18 Water performance tests – Stability test</b>		<b>Regulations: LSA Code II/2.2.1.4; MSC.81(70) 1/2.8.10</b>																																																																																																																																														
Test Procedure	Acceptance Criteria	Significant Test Data																																																																																																																																														
<p>The test subject should attain a relaxed face-up position of static balance in the water. The subject should be instructed to assume a foetal position as follows: "place your elbows against your sides, your hands on your stomach, under the lifejacket if possible, and bring your knees up as close to your chest as possible."</p> <p>The subject should be rotated clockwise around the longitudinal axis of the torso by grasping the subject's shoulders or upper areas of the lifejacket so that the subject attains a <math>55 \pm 5</math> degree list. The subject should then be released. The subject should return to a stable face-up position.</p> <p>The test should then be conducted with the subject rotated counter-clockwise.</p> <p>The entire test should then be repeated with the test subject wearing the RTD.</p> <p>The test should be conducted using lifejackets that have been inflated both automatically and manually, and also with one of the compartments uninflated.</p>	<p>The candidate lifejacket should not roll any subject face down in the water.</p> <p style="text-align:center;">(a) + (b) = 0</p> <p>The number of subjects who are returned to the stable face-up foetal position in the candidate lifejacket should be at least equal to the number who are returned to the stable face-up foetal position in the RTD.</p> <p style="text-align:center;">(e) ≤ (g) And (f) ≤ (h)</p>	<table border="1" style="width:100%; border-collapse: collapse; text-align:center;"> <thead> <tr> <th rowspan="3">Subj</th> <th colspan="4">Did the subject roll face-down? (Yes/No)</th> <th colspan="4">Did the subject return to a stable face-up position? (Yes/No)</th> </tr> <tr> <th colspan="2">Candidate</th> <th colspan="2">RTD</th> <th colspan="2">Candidate</th> <th colspan="2">RTD</th> </tr> <tr> <th>CW</th> <th>CCW</th> <th>CW</th> <th>CCW</th> <th>CW</th> <th>CCW</th> <th>CW</th> <th>CCW</th> </tr> </thead> <tbody> <tr><td>1</td><td></td><td></td><td></td><td></td><td></td><td></td><td></td><td></td></tr> <tr><td>2</td><td></td><td></td><td></td><td></td><td></td><td></td><td></td><td></td></tr> <tr><td>3</td><td></td><td></td><td></td><td></td><td></td><td></td><td></td><td></td></tr> <tr><td>4</td><td></td><td></td><td></td><td></td><td></td><td></td><td></td><td></td></tr> <tr><td>5</td><td></td><td></td><td></td><td></td><td></td><td></td><td></td><td></td></tr> <tr><td>6</td><td></td><td></td><td></td><td></td><td></td><td></td><td></td><td></td></tr> <tr><td>7</td><td></td><td></td><td></td><td></td><td></td><td></td><td></td><td></td></tr> <tr><td>8</td><td></td><td></td><td></td><td></td><td></td><td></td><td></td><td></td></tr> <tr><td>9</td><td></td><td></td><td></td><td></td><td></td><td></td><td></td><td></td></tr> <tr><td>10</td><td></td><td></td><td></td><td></td><td></td><td></td><td></td><td></td></tr> <tr><td>11</td><td></td><td></td><td></td><td></td><td></td><td></td><td></td><td></td></tr> <tr><td>12</td><td></td><td></td><td></td><td></td><td></td><td></td><td></td><td></td></tr> <tr> <td>Total "No"</td> <td>(a)</td> <td>(b)</td> <td>(c)</td> <td>(d)</td> <td>(e)</td> <td>(f)</td> <td>(g)</td> <td>(h)</td> </tr> </tbody> </table>	Subj	Did the subject roll face-down? (Yes/No)				Did the subject return to a stable face-up position? (Yes/No)				Candidate		RTD		Candidate		RTD		CW	CCW	CW	CCW	CW	CCW	CW	CCW	1									2									3									4									5									6									7									8									9									10									11									12									Total "No"	(a)	(b)	(c)	(d)	(e)	(f)	(g)	(h)
Subj	Did the subject roll face-down? (Yes/No)				Did the subject return to a stable face-up position? (Yes/No)																																																																																																																																											
	Candidate			RTD		Candidate		RTD																																																																																																																																								
	CW	CCW	CW	CCW	CW	CCW	CW	CCW																																																																																																																																								
1																																																																																																																																																
2																																																																																																																																																
3																																																																																																																																																
4																																																																																																																																																
5																																																																																																																																																
6																																																																																																																																																
7																																																																																																																																																
8																																																																																																																																																
9																																																																																																																																																
10																																																																																																																																																
11																																																																																																																																																
12																																																																																																																																																
Total "No"	(a)	(b)	(c)	(d)	(e)	(f)	(g)	(h)																																																																																																																																								

<b>Inflatable lifejackets (Adults &amp; Child)</b>	Manufacturer: _____ Model: _____ Lot/Serial Number: _____	Date: _____ Time: _____ Surveyor: _____ Organization: _____																																													
<b>2.2.2.19 Water performance tests – Swimming and water emergence test</b>		<b>Regulations: LSA Code II/2.2.1.4; MSC.81(70) 1/2.8.11</b>																																													
Test Procedure	Acceptance Criteria	Significant Test Data																																													
<p>All test subjects, without wearing the lifejacket, should attempt to swim 25 m and board a liferaft or rigid platform with its surface 300 mm above the water surface. All test subjects who successfully complete this task should perform it again wearing the lifejacket.</p> <p>The test should be conducted using lifejackets that have been inflated both automatically and manually, and also with one of the compartments uninflated.</p>	<p>At least two-thirds of the subjects who can accomplish the task without the lifejacket should also be able to perform it with the lifejacket.</p> <p>(b) ≥ 2/3 (a)</p>	<p>Apparatus Used: _____ Liferaft or Rigid Platform</p> <p>Record whether test subjects can successfully board liferaft or platform:</p> <table border="1" style="width:100%; border-collapse: collapse;"> <thead> <tr> <th style="width:10%;">Subj</th> <th style="width:20%;">Without lifejacket</th> <th style="width:20%;">With lifejacket</th> <th style="width:50%;"></th> </tr> </thead> <tbody> <tr><td>1</td><td></td><td></td><td rowspan="12" style="vertical-align: top;">           (b) _____            2/3 (a) _____             Passed / Failed             Comments/Observations         </td></tr> <tr><td>2</td><td></td><td></td></tr> <tr><td>3</td><td></td><td></td></tr> <tr><td>4</td><td></td><td></td></tr> <tr><td>5</td><td></td><td></td></tr> <tr><td>6</td><td></td><td></td></tr> <tr><td>7</td><td></td><td></td></tr> <tr><td>8</td><td></td><td></td></tr> <tr><td>9</td><td></td><td></td></tr> <tr><td>10</td><td></td><td></td></tr> <tr><td>11</td><td></td><td></td></tr> <tr><td>12</td><td></td><td></td></tr> <tr> <td><b>Total</b></td> <td>(a)</td> <td>(b)</td> <td></td> </tr> </tbody> </table>	Subj	Without lifejacket	With lifejacket		1			(b) _____ 2/3 (a) _____  Passed / Failed  Comments/Observations	2			3			4			5			6			7			8			9			10			11			12			<b>Total</b>	(a)	(b)	
Subj	Without lifejacket	With lifejacket																																													
1			(b) _____ 2/3 (a) _____  Passed / Failed  Comments/Observations																																												
2																																															
3																																															
4																																															
5																																															
6																																															
7																																															
8																																															
9																																															
10																																															
11																																															
12																																															
<b>Total</b>	(a)	(b)																																													

<b>Inflatable lifejackets (Adults &amp; Child)</b>	Manufacturer: _____ Model: _____ Lot/Serial Number: _____	Date: _____ Time: _____ Surveyor: _____ Organization: _____																																																																																																																																																																																			
<b>2.2.2.20 Infant and children's lifejacket tests – Test subjects</b>		<b>Regulations: LSA Code II/2.2.1.8; MSC.81(70) 1/2.9 – 2.9.1, 2.10</b>																																																																																																																																																																																			
Test Procedure	Acceptance Criteria	Significant Test Data																																																																																																																																																																																			
<p>As far as possible, similar tests (to the adult tests) should be applied for approval of lifejackets suitable for infants and children.</p> <p>For child-size lifejackets, tests should be carried out with at least 9 able-bodied persons, and for infant-size lifejackets, tests should be carried out with at least 5 able-bodied persons.</p> <p>All test subjects should be selected according to table 2.2 or table 2.3 as follows:</p> <p>.1 One subject should be selected per each cell containing a "1".</p> <p>.2 Remaining subjects should be selected from cells containing an "X", without repeating a cell.</p> <p>.3 At least 40% of the subjects should be male and at least 40% female.</p> <p>.4 Devices for infants should be tested on infants as small as 6 kg mass.</p> <p>.5 A manikin or manikins may be substituted for test subjects if the manikin or manikins have been demonstrated to provide representative results compared to human subjects.</p>	<p style="text-align:center;"><b>Table 2.2 - Selection of Child Test Subjects</b></p> <table border="1" style="width:100%; border-collapse: collapse; text-align:center;"> <thead> <tr> <th rowspan="2">eight range (cm)</th> <th colspan="11">Weight Range (kg)</th> </tr> <tr> <th>14-17</th> <th>17-20</th> <th>20-22</th> <th>22-25</th> <th>25-28</th> <th>28-30</th> <th>30-33</th> <th>33-36</th> <th>36-38</th> <th>38-41</th> <th>41-43</th> </tr> </thead> <tbody> <tr> <td>79-105</td> <td>1</td> <td>X</td> <td></td> <td></td> <td></td> <td></td> <td></td> <td></td> <td></td> <td></td> <td></td> </tr> <tr> <td>90-118</td> <td></td> <td>X</td> <td>1</td> <td></td> <td></td> <td></td> <td></td> <td></td> <td></td> <td></td> <td></td> </tr> <tr> <td>102-130</td> <td></td> <td></td> <td></td> <td>1</td> <td>X</td> <td></td> <td></td> <td></td> <td></td> <td></td> <td></td> </tr> <tr> <td>112-135</td> <td></td> <td></td> <td></td> <td></td> <td>X</td> <td>1</td> <td></td> <td></td> <td></td> <td></td> <td></td> </tr> <tr> <td>122-150</td> <td></td> <td></td> <td></td> <td></td> <td></td> <td></td> <td>1</td> <td>1</td> <td>X</td> <td></td> <td></td> </tr> <tr> <td>145-165</td> <td></td> <td></td> <td></td> <td></td> <td></td> <td></td> <td></td> <td></td> <td>X</td> <td>1</td> <td>1</td> </tr> </tbody> </table> <p style="text-align:center;"><b>Table 2.3 - Selection of Infant Test Subjects</b></p> <table border="1" style="width:100%; border-collapse: collapse; text-align:center;"> <thead> <tr> <th rowspan="2">Height range (cm)</th> <th colspan="3">Weight Range (kg)</th> </tr> <tr> <th>Less than 11</th> <th>11-14</th> <th>14-17</th> </tr> </thead> <tbody> <tr> <td>Less than 83</td> <td>1</td> <td>X</td> <td></td> </tr> <tr> <td>79-105</td> <td>X</td> <td>1</td> <td>1</td> </tr> <tr> <td>90-118</td> <td></td> <td></td> <td>X</td> </tr> </tbody> </table>	eight range (cm)	Weight Range (kg)											14-17	17-20	20-22	22-25	25-28	28-30	30-33	33-36	36-38	38-41	41-43	79-105	1	X										90-118		X	1									102-130				1	X							112-135					X	1						122-150							1	1	X			145-165									X	1	1	Height range (cm)	Weight Range (kg)			Less than 11	11-14	14-17	Less than 83	1	X		79-105	X	1	1	90-118			X	<p>Size: Infant / Child</p> <table border="1" style="width:100%; border-collapse: collapse; text-align:center;"> <thead> <tr> <th>Subj</th> <th>SEX (M/F)</th> <th>HEIGHT (m)</th> <th>WEIGHT (kg)</th> <th>Manikin? (Yes*/No)</th> </tr> </thead> <tbody> <tr><td>1</td><td></td><td></td><td></td><td></td></tr> <tr><td>2</td><td></td><td></td><td></td><td></td></tr> <tr><td>3</td><td></td><td></td><td></td><td></td></tr> <tr><td>4</td><td></td><td></td><td></td><td></td></tr> <tr><td>5</td><td></td><td></td><td></td><td></td></tr> <tr><td>6</td><td></td><td></td><td></td><td></td></tr> <tr><td>7</td><td></td><td></td><td></td><td></td></tr> <tr><td>8</td><td></td><td></td><td></td><td></td></tr> <tr><td>9</td><td></td><td></td><td></td><td></td></tr> <tr><td></td><td></td><td></td><td></td><td></td></tr> <tr><td></td><td></td><td></td><td></td><td></td></tr> <tr><td></td><td></td><td></td><td></td><td></td></tr> </tbody> </table> <p>*Manikin description: _____</p>	Subj	SEX (M/F)	HEIGHT (m)	WEIGHT (kg)	Manikin? (Yes*/No)	1					2					3					4					5					6					7					8					9																			
eight range (cm)	Weight Range (kg)																																																																																																																																																																																				
	14-17	17-20	20-22	22-25	25-28	28-30	30-33	33-36	36-38	38-41	41-43																																																																																																																																																																										
79-105	1	X																																																																																																																																																																																			
90-118		X	1																																																																																																																																																																																		
102-130				1	X																																																																																																																																																																																
112-135					X	1																																																																																																																																																																															
122-150							1	1	X																																																																																																																																																																												
145-165									X	1	1																																																																																																																																																																										
Height range (cm)	Weight Range (kg)																																																																																																																																																																																				
	Less than 11	11-14	14-17																																																																																																																																																																																		
Less than 83	1	X																																																																																																																																																																																			
79-105	X	1	1																																																																																																																																																																																		
90-118			X																																																																																																																																																																																		
Subj	SEX (M/F)	HEIGHT (m)	WEIGHT (kg)	Manikin? (Yes*/No)																																																																																																																																																																																	
1																																																																																																																																																																																					
2																																																																																																																																																																																					
3																																																																																																																																																																																					
4																																																																																																																																																																																					
5																																																																																																																																																																																					
6																																																																																																																																																																																					
7																																																																																																																																																																																					
8																																																																																																																																																																																					
9																																																																																																																																																																																					

<b>Inflatable lifejackets (Adults &amp; Child)</b>	Manufacturer: _____ Model: _____ Lot/Serial Number: _____	Date: _____ Time: _____ Surveyor: _____ Organization: _____
<b>2.2.2.21 Infant and children's lifejacket – Water performance tests – Righting test</b>		<b>Regulations: LSA Code II/ 2.2.1.8; MSC.81(70)1/ 2.9.2-2.9.3, Annex 2, Annex 3, 2.10.3</b>
<p style="text-align: center;">Test Procedure</p>	<p style="text-align: center;">Acceptance Criteria</p>	<p style="text-align: center;">Significant test data</p>
<p>This portion of the test is intended to determine the ability of the lifejacket to assist a helpless person or one in an exhausted or unconscious state and to show that the lifejacket does not unduly restrict movement.</p> <p>The in-water performance of a lifejacket is evaluated by comparison to the performance of a suitable size standard reference lifejacket, i.e. Reference Test Device (RTD) as specified in appendices 2 to 3.</p> <p>All tests should be carried out in fresh water under still conditions. Each test for a candidate lifejacket and the relevant RTD should be conducted on the same day.</p> <p>The tests may be modified for child test subjects under 12 years of age who are not comfortable in water, so as to ensure their safety and cooperation.</p> <p>Prior to taking measurements, the proper fit, donning, and fastening of the RTD on the subject should be checked and corrected as necessary.</p> <p>After entering the water, care should be taken to ensure that there is no significant amount of air unintentionally trapped in the lifejacket or swimming costume.</p> <p>The test should be conducted using lifejackets that have been inflated both automatically and manually, and also with one of the compartments uninflated.</p>	<p>The RTD should be constructed and calibrated according to MSC.81(70), annex 2 or 3, as applicable to the size.</p>	<p>RTD Size: Infant / Child</p> <p>RTD Constructed by: _____ date: _____</p> <p>Validated by: _____ date: _____</p> <p>Calibrated by: _____ date: _____</p>

<b>Inflatable lifejackets (Adults &amp; Child)</b>	Manufacturer: _____ Model: _____ Lot/Serial Number: _____	Date: _____ Time: _____ Surveyor: _____ Organization: _____																																																																																																																																																																																																																																		
<b>2.2.2.21 Infant and children's lifejacket – Water performance tests – Righting test (Continued)</b>		<b>Regulations: LSA Code II/ 2.2.1.8; MSC.81(70)1/ 2.9.2-2.9.3, annex 2, annex 3, 2.10.3</b>																																																																																																																																																																																																																																		
Test Procedure	Acceptance Criteria	Significant Test Data																																																																																																																																																																																																																																		
<p>Each test subject should assume a prone, face down position in the water, but with the head lifted up so the mouth is out of the water. The subject's feet should be supported, shoulder width apart, with the heels just below the surface of the water.</p> <p>After assuming a starting position with the legs straight and arms along the sides, the subject should then be instructed in the following sequence to allow the body to gradually and completely relax into a natural floating posture: allow the arms and shoulders to relax; allow the legs to relax; and then the spine and neck, letting the head fall into the water while breathing out normally.</p>	<p>The period of time until the mouth of the test subject comes clear of the water should be recorded to the nearest 1/10 of a second, starting from when the subject's feet are released.</p> <p>The test should be conducted a total of six times, and the highest and lowest times discarded. The test should then be conducted a total of six times in the RTD and the highest and lowest times discarded.</p>	<table border="1" style="width:100%; border-collapse: collapse;"> <thead> <tr> <th rowspan="2" style="width:5%;">Subj</th> <th colspan="7" style="text-align:center;">CANDIDATE DEVICE TIME (sec) TRIAL</th> <th colspan="7" style="text-align:center;">REFERENCE VEST TIME (sec) TRIAL</th> </tr> <tr> <th>#1</th><th>#2</th><th>#3</th><th>#4</th><th>#5</th><th>#6</th><th>AVG *</th> <th>#1</th><th>#2</th><th>#3</th><th>#4</th><th>#5</th><th>#6</th><th>AVG *</th> </tr> </thead> <tbody> <tr><td>1</td><td></td><td></td><td></td><td></td><td></td><td></td><td></td><td></td><td></td><td></td><td></td><td></td><td></td><td></td></tr> <tr><td>2</td><td></td><td></td><td></td><td></td><td></td><td></td><td></td><td></td><td></td><td></td><td></td><td></td><td></td><td></td></tr> <tr><td>3</td><td></td><td></td><td></td><td></td><td></td><td></td><td></td><td></td><td></td><td></td><td></td><td></td><td></td><td></td></tr> <tr><td>4</td><td></td><td></td><td></td><td></td><td></td><td></td><td></td><td></td><td></td><td></td><td></td><td></td><td></td><td></td></tr> <tr><td>5</td><td></td><td></td><td></td><td></td><td></td><td></td><td></td><td></td><td></td><td></td><td></td><td></td><td></td><td></td></tr> <tr><td>6</td><td></td><td></td><td></td><td></td><td></td><td></td><td></td><td></td><td></td><td></td><td></td><td></td><td></td><td></td></tr> <tr><td>7</td><td></td><td></td><td></td><td></td><td></td><td></td><td></td><td></td><td></td><td></td><td></td><td></td><td></td><td></td></tr> <tr><td>8</td><td></td><td></td><td></td><td></td><td></td><td></td><td></td><td></td><td></td><td></td><td></td><td></td><td></td><td></td></tr> <tr><td>9</td><td></td><td></td><td></td><td></td><td></td><td></td><td></td><td></td><td></td><td></td><td></td><td></td><td></td><td></td></tr> <tr><td></td><td></td><td></td><td></td><td></td><td></td><td></td><td></td><td></td><td></td><td></td><td></td><td></td><td></td><td></td></tr> <tr><td></td><td></td><td></td><td></td><td></td><td></td><td></td><td></td><td></td><td></td><td></td><td></td><td></td><td></td><td></td></tr> <tr> <td colspan="7" style="text-align:center;"><b>Average candidate turn time (sec):</b></td> <td></td> <td colspan="7" style="text-align:center;"><b>Average RTD turn time (sec):</b></td> <td></td> </tr> <tr> <td colspan="7" style="text-align:center;"><b># of candidate no turns (NT):</b></td> <td></td> <td colspan="7" style="text-align:center;"><b># of RTD no turns (NT):</b></td> <td></td> </tr> </tbody> </table>	Subj	CANDIDATE DEVICE TIME (sec) TRIAL							REFERENCE VEST TIME (sec) TRIAL							#1	#2	#3	#4	#5	#6	AVG *	#1	#2	#3	#4	#5	#6	AVG *	1															2															3															4															5															6															7															8															9																																													<b>Average candidate turn time (sec):</b>								<b>Average RTD turn time (sec):</b>								<b># of candidate no turns (NT):</b>								<b># of RTD no turns (NT):</b>							
		Subj		CANDIDATE DEVICE TIME (sec) TRIAL							REFERENCE VEST TIME (sec) TRIAL																																																																																																																																																																																																																									
			#1	#2	#3	#4	#5	#6	AVG *	#1	#2	#3	#4	#5	#6	AVG *																																																																																																																																																																																																																				
		1																																																																																																																																																																																																																																		
		2																																																																																																																																																																																																																																		
		3																																																																																																																																																																																																																																		
		4																																																																																																																																																																																																																																		
		5																																																																																																																																																																																																																																		
		6																																																																																																																																																																																																																																		
		7																																																																																																																																																																																																																																		
		8																																																																																																																																																																																																																																		
		9																																																																																																																																																																																																																																		
<b>Average candidate turn time (sec):</b>								<b>Average RTD turn time (sec):</b>																																																																																																																																																																																																																												
<b># of candidate no turns (NT):</b>								<b># of RTD no turns (NT):</b>																																																																																																																																																																																																																												

2.2.2.21 Infant and children's lifejacket – Water performance tests – Righting test (Continued)		Regulations: LSA Code II/ 2.2.1.8; MSC.81(70)1/ 2.9.2-2.9.3, annex 2, annex 3, 2.10.3
Test Procedure	Acceptance Criteria	Significant Test Data
<p>During the relaxation phase, the subject should be maintained in a stable face down position.</p> <p>Immediately after the subject has relaxed, with the face in the water, simulating a state of utter exhaustion, the subject's feet should be released.</p>	<p>Turning time: the average turn time for all subjects in the candidate lifejacket should not exceed the average time in the RTD plus 1 s.</p> <p>The number of "no-turns", if any, should not exceed the number in the RTD.</p>	<p>(* Delete highest and lowest value)</p> <p>Average candidate turn time <math>\leq</math> Average RTD turn time RTD +1s    Passed _____    Failed _____</p> <p># of candidate no turns (NT): <math>\leq</math> # of RTD no turns (NT):    Passed _____    Failed _____</p> <p>Comments/Observations:</p>

<b>Inflatable lifejackets (Adults &amp; Child)</b>	Manufacturer: _____ Model: _____ Lot/Serial Number: _____	Date: _____ Time: _____ Surveyor: _____ Organization: _____						
<b>2.2.2.22 Infant and children's lifejacket - Water performance tests – Static balance measurements</b>		<b>Regulations: LSA Code II/ 2.2.1.8; MSC.81(70)1/ 2.8.6, 2.9.2-2.9.3, 2.10.3, Annex 2 &amp; 3</b>						
<b>Test Procedure</b>	<b>Significant Test Data</b>							
<p>At the conclusion of the righting tests, without making any adjustments in body or lifejacket position, the following measurements should be made with the subject floating in the relaxed face-up position of static balance resulting from the preceding tests.</p> <p>Infant lifejackets should meet the turning time and freeboard requirements, however, the requirements for torso angle, faceplane and mobility may be relaxed if necessary in order to:</p> <p>.1 contribute to the rescue of the infant by a caretaker;</p> <p>.2 allow the infant to be fastened to a caretaker and contribute to keeping the infant close to the caretaker;</p> <p>.3 keep the infant dry, with free respiratory passages;</p> <p>.4 protect the infant against bumps and jolts during the evacuation; and</p> <p>.5 allow a caretaker to monitor and control heat loss by the infant.</p>		Freeboard (mm)		Faceplane (deg)		Torso angle (deg)		Light
		CLJ	RTD	CLJ	RTD	CLJ	RTD	Visible?
	1							
	2							
	3							
	4							
	5							
	6							
	7							
	8							
	9							
	Avg							XXXXX
<p>CLJ – Candidate Lifejacket RTD – Reference Test Device</p>								



<b>Inflatable lifejackets (Adults &amp; Child)</b>	Manufacturer: _____ Model: _____ Lot/Serial Number: _____	Date: _____ Time: _____ Surveyor: _____ Organization: _____
<b>2.2.2.22 Infant and children's lifejacket - Water performance tests – Static balance measurements (Continued)</b>		<b>Regulations: LSA Code II/ 2.2.1.8; MSC.81(70)1/ 2.8.6, 2.9.2-2.9.3, 2.10.3, Annex 2 &amp; 3</b>
Test Procedure	Acceptance Criteria	Significant Test Data
<ol style="list-style-type: none"> <li>1. Freeboard – The distance measured perpendicularly from the surface of the water to the lowest point of the subject's mouth where respiration may be impeded, if the mouth were not held shut. The lowest side of the mouth should be measured if the left and right sides are not level.</li> <li>2. Faceplane angle – The angle, relative to the surface of the water, of the plane formed between the most forward part of the forehead and chin.</li> <li>3. Torso angle – The angle, relative to vertical, of the line formed by the forward points of the shoulder and hipbone (ilium portion of the pelvis).</li> <li>4. List angle – The angle relative to the surface of the water and a line between the left and right shoulder or a line through the ears if only the head is tilted.</li> </ol>	<p>Freeboard: the average freeboard of all the subjects should not be less than the average for the RTD minus 10 mm.</p> <p>Faceplane angles: The average of all subjects' faceplane angles should be not less than the average for the RTD minus 10°.</p> <p>Torso angles: the average of all subjects' torso angles should be not less than the average for the RTD minus 10°.</p> <p>Lifejacket light location: the position of the lifejacket light should permit it to be visible over as great a segment of the upper hemisphere as is practicable.</p>	<p>Average freeboard, all subjects <math>\geq</math> average freeboard for RTD minus 10 mm</p> <p>Passed _____ Failed _____</p> <p>Average faceplane angle, all subjects <math>\geq</math> average for RTD minus 10°</p> <p>Passed _____ Failed _____</p> <p>Average torso angles, all subjects <math>\geq</math> average for RTD minus 10°</p> <p>Passed _____ Failed _____</p> <p>Does the location of the lifejacket light permit it to be visible over as great a segment of the upper hemisphere as practicable?</p> <p>Comments/Observations:</p>

<b>Inflatable lifejackets (Adults &amp; Child)</b>	Manufacturer: _____ Model: _____ Lot/Serial Number: _____	Date: _____ Time: _____ Surveyor: _____ Organization: _____
<b>2.2.2.23 Children's lifejacket – Water performance tests – Jump and drop test</b>		<b>Regulations: LSA Code II/2.2.1.8, 2.2.2.21; MSC.81(70) 1/ 2.9, 2.8.8, 2.8.9, 2.10.3</b>
Test Procedure	Acceptance Criteria	Significant Test Data
<p>Without readjusting the lifejacket, the test subject should jump vertically into the water, feet first, from a height of at least 1m while holding the arms over the head. Upon entering the water, the test subject should relax to simulate a state of utter exhaustion. The freeboard to the mouth should be recorded after the test subject comes to rest. The test should be repeated from a height of at least 4.5m.</p> <p>When jumping into the water, the test subject should hold on to the lifejacket during water entry to avoid possible injury. Upon entering the water, the test subject should relax to simulate a state of utter exhaustion. The freeboard to the mouth should be recorded after the test subject comes to rest.</p> <p>The lifejacket and its attachments should be examined for any damage. If injury is believed likely from any jump or drop test, the lifejacket should be rejected or the test delayed until test from a lower height or with additional precautions demonstrate that the risk from the required test is acceptable.</p> <p><u>NOTE: JUMP AND DROP TESTS SHOULD NOT BE REPEATED IN THE RTD.</u></p>	<p>Five of the nine subjects should perform the jump and drop test.</p> <p>When conducting water performance tests under 2.8, infant and child-size lifejackets should meet the following requirements for their critical flotation stability characteristics.</p> <p>Following the jump and drop test, the lifejacket should:</p> <p>.1 surface the test subject in a face up position with an average freeboard for all the subjects of not less than the average determined for the RTD after the turning test in accordance with 2.2.1.23 minus 15 mm;</p> <p>.2 not be dislodged or cause harm to the test subject;</p> <p>.3 have no damage that would affect its in-water performance or buoyance;</p>	<p>See following page for test data</p> <p>1 m Jump</p> <p>Average freeboard, all subjects: _____ mm (A) Average freeboard for RTD (from 2.2.18) : _____ mm (B)</p> <p>(B) – (A)= _____ ≤ 15 mm Pass / Fail</p> <p>Did the lifejacket become dislodged or cause harm to the test subject?: Yes / No</p> <p>Did the lifejacket have damage that would affect its in-water performance or buoyance?: Yes / No</p> <p>Did the lifejacket have damage to its attachments?: Yes / No</p> <p>4.5 m Jump</p> <p>Average freeboard, all subjects: _____ mm (A) Average freeboard for RTD (from 2.2.18): _____ mm (B)</p> <p>(B) – (A)= _____ ≤ 15 mm Pass / Fail</p> <p>Did the lifejacket become dislodged or cause harm to the test subject?: Yes / No</p> <p>Did the lifejacket have damage that would affect its in-water performance or buoyance?: Yes / No</p>

2.2.2.23 Children's lifejacket – Water performance tests – Jump and drop test		Regulations: LSA Code II/2.2.1.8, 2.2.2.21; MSC.81(70) 1/ 2.9, 2.8.8, 2.8.9, 2.10.3
Test Procedure	Acceptance Criteria	Significant Test Data
<p>Note: Water tests using children should avoid causing distress or risk to the child. Consideration should be taken of their age and ability.</p> <p>The test should be conducted using lifejackets that have been inflated both automatically and manually, and also with one of the compartments uninflated.</p>	<p>and</p> <p>.4 have no damage to its attachments.</p>	<p>Did the lifejacket have damage to its attachments?: Yes / No</p> <p>Comments/Observations</p>

<b>Inflatable lifejackets (Adults &amp; Child)</b>	Manufacturer: _____ Model: _____ Lot/Serial Number: _____	Date: _____ Time: _____ Surveyor: _____ Organization: _____
--	---	---

<b>2.2.2.23 Children's lifejacket – Water performance tests – Jump and drop tests</b>	<b>Regulations: LSA Code II/ 2.2.1.8, 2.1.5.6; MSC.81(70)1/2.9, 2.8.8, 2.8.9 and 2.10.3</b>
---	---

TEST DATA SHEET (1 m Jump)						
Subj	Subject surfaced faceup? (Yes/No)	Freeboard (mm)	Lifejacket became dislodged (Yes/No)	Subject was harmed? (Yes/No)	Damage to lifejacket or attachments (Yes/No)	Comments/ Observations
1						
2						
3						
4						
5						

<b>2.2.1.23 Children's lifejacket – Water performance tests – Jump and drop tests</b>	<b>Regulations: LSA Code II/ 2.2.1.8, 2.2.1.2.5; MSC.81(70)1/2.9, 2.8.8 and 2.8.9</b>
---	---

TEST DATA SHEET (4.5 m Jump)						
Subj	Subject surfaced faceup? (Yes/No)	Freeboard (mm)	Lifejacket became dislodged (Yes/No)	Subject was harmed? (Yes/No)	Damage to lifejacket or attachments (Yes/No)	Comments/ Observations
1						
2						
3						
4						
5						

<b>Inflatable lifejackets (Adults &amp; Child)</b>	Manufacturer: _____ Model: _____ Lot/Serial Number: _____	Date: _____ Time: _____ Surveyor: _____ Organization: _____																																																																																																																																														
<b>2.2.2.24 Infant and children's lifejacket – Water performance tests – stability test</b>		<b>Regulations: LSA Code II/2.2.1.8, 2.2.1.4; MSC.81(70) 1/2.8.10, 2.9.2, 2.10.3</b>																																																																																																																																														
Test Procedure	Acceptance Criteria	Significant Test Data																																																																																																																																														
<p>The test subject should attain a relaxed face-up position of static balance in the water. The subject should be instructed to assume a foetal position as follows: "place your elbows against your sides, your hands on your stomach, under the lifejacket if possible, and bring your knees up as close to your chest as possible."</p> <p>The subject should be rotated clockwise around the longitudinal axis of the torso by grasping the subject's shoulders or upper areas of the lifejacket so that the subject attains a <math>55 \pm 5</math> degree list. The subject should then be released. The subject should return to a stable face-up position.</p> <p>The test should then be conducted with the subject rotated counter-clockwise. The entire test should then be repeated with the test subject wearing the RTD.</p> <p>The test should be conducted using lifejackets that have been inflated both automatically and manually, and also with one of the compartments uninflated.</p>	<p>The candidate lifejacket should not roll any subject face down in the water.</p> <p style="text-align: center;"><math>(a) + (b) = 0</math></p> <p>The number of subjects who are returned to the stable face-up foetal position in the candidate lifejacket should be at least equal to the number who are returned to the stable face-up foetal position in the RTD.</p> <p style="text-align: center;"><math>(e) \leq (g)</math> And <math>(f) \leq (h)</math></p>	<table border="1" style="width:100%; border-collapse: collapse; text-align: center;"> <thead> <tr> <th rowspan="3">Subj</th> <th colspan="4">Did the subject roll face-down? (Yes/No)</th> <th colspan="4">Did the subject return to a stable face-up position? (Yes/No)</th> </tr> <tr> <th colspan="2">Candidate</th> <th colspan="2">RTD</th> <th colspan="2">Candidate</th> <th colspan="2">RTD</th> </tr> <tr> <th>CW</th> <th>CCW</th> <th>CW</th> <th>CCW</th> <th>CW</th> <th>CCW</th> <th>CW</th> <th>CCW</th> </tr> </thead> <tbody> <tr><td>1</td><td></td><td></td><td></td><td></td><td></td><td></td><td></td><td></td></tr> <tr><td>2</td><td></td><td></td><td></td><td></td><td></td><td></td><td></td><td></td></tr> <tr><td>3</td><td></td><td></td><td></td><td></td><td></td><td></td><td></td><td></td></tr> <tr><td>4</td><td></td><td></td><td></td><td></td><td></td><td></td><td></td><td></td></tr> <tr><td>5</td><td></td><td></td><td></td><td></td><td></td><td></td><td></td><td></td></tr> <tr><td>6</td><td></td><td></td><td></td><td></td><td></td><td></td><td></td><td></td></tr> <tr><td>7</td><td></td><td></td><td></td><td></td><td></td><td></td><td></td><td></td></tr> <tr><td>8</td><td></td><td></td><td></td><td></td><td></td><td></td><td></td><td></td></tr> <tr><td>9</td><td></td><td></td><td></td><td></td><td></td><td></td><td></td><td></td></tr> <tr><td></td><td></td><td></td><td></td><td></td><td></td><td></td><td></td><td></td></tr> <tr><td></td><td></td><td></td><td></td><td></td><td></td><td></td><td></td><td></td></tr> <tr><td></td><td></td><td></td><td></td><td></td><td></td><td></td><td></td><td></td></tr> <tr> <td>Total "No"</td> <td>(a)</td> <td>(b)</td> <td>(c)</td> <td>(d)</td> <td>(e)</td> <td>(f)</td> <td>(g)</td> <td>(h)</td> </tr> </tbody> </table>	Subj	Did the subject roll face-down? (Yes/No)				Did the subject return to a stable face-up position? (Yes/No)				Candidate		RTD		Candidate		RTD		CW	CCW	CW	CCW	CW	CCW	CW	CCW	1									2									3									4									5									6									7									8									9																																				Total "No"	(a)	(b)	(c)	(d)	(e)	(f)	(g)	(h)
Subj	Did the subject roll face-down? (Yes/No)				Did the subject return to a stable face-up position? (Yes/No)																																																																																																																																											
	Candidate			RTD		Candidate		RTD																																																																																																																																								
	CW	CCW	CW	CCW	CW	CCW	CW	CCW																																																																																																																																								
1																																																																																																																																																
2																																																																																																																																																
3																																																																																																																																																
4																																																																																																																																																
5																																																																																																																																																
6																																																																																																																																																
7																																																																																																																																																
8																																																																																																																																																
9																																																																																																																																																
Total "No"	(a)	(b)	(c)	(d)	(e)	(f)	(g)	(h)																																																																																																																																								

<b>Inflatable lifejackets (Adults &amp; Child)</b>	Manufacturer: _____ Model: _____ Lot/Serial Number: _____	Date: _____ Time: _____ Surveyor: _____ Organization: _____
<b>2.2.2.25 Infant and children's lifejacket - Mobility test</b>		<b>Regulations: LSA Code II/2.2.1.8; MSC.81(70) 1/2.9.2.5, 2.10.3</b>
<b>Test Procedure</b>	<b>Acceptance Criteria</b>	<b>Significant Test Data</b>
<p>To be considered in and out of the water.</p> <p>Mobility of the subject both in and out of the water should be given consideration in determining the acceptability of a device for approval and should be compared to mobility when wearing the appropriate size RTD when climbing out of the water, going up and down stairs, picking up an article from the floor, and then drinking from a cup.</p>	<p>Assistance may be given to board a survival craft, but wearer mobility should not be reduced to any greater extent than by the appropriate size RTD.</p>	<p>Does the lifejacket provide for acceptable mobility of the test subjects both in and out of the water and is comparative to the mobility of wearing the RTD?</p> <p>YES <input type="checkbox"/> NO <input type="checkbox"/></p> <p>Passed _____ Failed _____</p> <p>Method of evaluation:</p> <p>Comments/Observations</p>

## 2.2.3 LIFEJACKET/IMMERSION SUIT LIGHTS EVALUATION AND TEST REPORT

**Remarks:** If an immersion suit is designed to be worn without a lifejacket, it should be fitted with a light complying with the requirements for lifejacket lights. The immersion suit light should be treated as a lifejacket light.

- 2.2.3.1 General information
  - 2.2.3.1.1 General data and specifications
  - 2.2.3.1.2 Submitted drawings, reports and documents
- 2.2.3.2 Visual inspection
  - 2.2.3.2.1 Approval marking
  - 2.2.3.2.2 Expiry marking
  - 2.2.3.2.3 Additional markings
  - 2.2.3.2.4 Electrical short circuit protection
  - 2.2.3.2.5 Visibility when attached to a lifejacket
  - 2.2.3.2.6 Construction and materials
- 2.2.3.3 Temperature cycling test
- 2.2.3.4 Light tests
- 2.2.3.5 Chromaticity test
- 2.2.3.6 Drop test
- 2.2.3.7 2 m light drop test
- 2.2.3.8 Switch arrangement test
- 2.2.3.9 Vibration test
- 2.2.3.10 Mould growth test
- 2.2.3.11 Corrosion and seawater resistance test
- 2.2.3.12 Test for oil resistance
- 2.2.3.13 Rain test and watertightness test
- 2.2.3.14 Fire test

**2.2.3 LIFEJACKET/IMMERSION SUIT LIGHTS  
EVALUATION AND TEST REPORT**

<b>Manufacturer</b>	
<b>Type</b>	
<b>Date</b>	
<b>Place</b>	
<b>Name Surveyor printed</b>	
<b>Signature</b>	
<b>Approving Organization</b>	



<b>Lifejacket/immersion suit lights</b>		Manufacturer: _____ Model: _____ Lot/Serial Number: _____		Date: _____ Time: _____ Surveyor: _____ Organization: _____	
<b>2.2.3.1.1 General data and specifications</b>			<b>Regulations: LSA Code; MSC.81(70)</b>		
General Information		Lifejacket Light Dimensions		Lifejacket Light Weight	
TYPE OF SWITCHING:	Automatic Manual			Detail of Bulb, Battery & Voltages Comments/Observations	
FLASHING					
LIGHT STEADY					
LIGHT					

<b>Lifejacket/immersion suit lights</b>	Manufacturer: _____	Date: _____ Time: _____
	Model: _____	Surveyor: _____
	Lot/Serial Number: _____	Organization: _____

**2.2.3.1.2 Submitted drawings, reports and documents**

Submitted drawings and documents			Status
Drawing No.	Revision No. & date	Title of drawing	

Submitted reports and documents			Status
Report/Document No.	Revision No. & date	Title of report / document	
		Maintenance Manual -	
		Operations Manual -	





<b>Lifejacket/immersion suit lights</b>	Manufacturer: _____	Date: _____	Time: _____
	Model: _____	Surveyor: _____	
	Lot/Serial Number: _____	Organization: _____	

Lifejacket and immersion suit light test flow chart

**Visual Inspection (all 12 lights) 2.2.3.1**

**Temperature Cycling (12 lights in groups of 4) 2.2.3.2:**

- lights 1 through 4: Light test (hot) 2.2.3.3
- lights 5 through 8: light test (cold) 2.2.3.3
- lights 9 through 12: light test (ambient) 2.2.3.3

Any one of the 12 lights - Chromaticity Test 2.2.3.4

Any one of the 12 lights - 4.5 m drop test 2.2.3.5 Same light: Light test (ambient) same light: Chromaticity Test

Any one of the 12 lights -2.0 m drop test 2.2.3.6 same light: Light test (ambient) same light: Chromaticity test

Any one of the 12 lights - Switch arrangement testsame light subjected to Vibration test 2.2.3.8 2.2.3.7

Any one of the 12 lights - 28 day mould growth test (may be waived) 2.2.3.9

Any one of the 12 lights - Corrosion and seawater resistance test (may be waived) 2.2.3.10

Any one of the 12 lights - Oil resistance test 2.2.3.11

Any one of the 12 lights - rain test and watertightness test 2.2.3.12

Any one of the 12 lights - fire test 2.2.3.13

<b>Lifejacket/immersion suit lights</b>	Manufacturer: _____ Model: _____ Lot/Serial Number: _____	Date: _____ Time: _____ Surveyor: _____ Organization: _____
<b>2.2.3.3 Temperature cycling test</b>		<b>Regulations: LSA Code 1.2.2.2; MSC.81(70) 1/ 1.2/1.2.1/1.2.2/10.3/10.3.1/10.3.2</b>
Test Procedure	Acceptance Criteria	Significant Test Data
<p>Twelve lifejacket lights which have passed the visual inspection should be subjected to temperature cycling. The following test should be carried out on twelve lifejacket lights:</p> <p>The lifejacket lights should be alternately subjected to surrounding temperatures of -30°C and at least +65°C. These alternating cycles need not follow immediately after each other and the following procedure, repeated for a total of not less than 10 cycles, is acceptable:</p> <ol style="list-style-type: none"> <li>.1 8 h exposure at a minimum temperature of +65°C to be completed in 1 day; and</li> <li>.2 the specimens removed from the warm chamber that same day and left exposed under ordinary room conditions at a temperature of 20°C ± 3°C until the next day;</li> <li>.3 an 8 h exposure at a maximum temperature of -30°C to be completed the next day; and</li> <li>.4 the specimens removed from the cold chamber that same day and left exposed under ordinary room conditions at a temperature of 20°C ± 3°C until the next day.</li> </ol> <p>After having passed the temperature cycling test the lights should be subjected next to the light tests.</p>	<p>The lifejacket lights should not be damaged in stowage throughout the air temperature range of -30°C to +65°C.</p> <p>The lifejacket lights should show no sign of loss of rigidity under high temperatures and, after the tests, should show no sign of damage such as shrinking, cracking, swelling, dissolution or change of mechanical qualities and should function after the test.</p>	<p><u>Results:</u></p> <p>PASS: _____ FAIL: _____</p> <p>Attach temperature cycling chart to record times spent at each temperature.</p> <p>Comments/Observations</p>

<b>Lifejacket/immersion suit lights</b>	Manufacturer: _____		Date: _____ Time: _____	
	Model: _____		Surveyor: _____	
	Lot/Serial Number: _____		Organization: _____	
<b>2.2.3.3 Temperature cycling test – Test data</b>			<b>Regulations: LSA Code 1.2.2.2; MSC.81(70) 1/ 1.2/1.2.1/1.2.2/10.3/10.3.1/10.3.2</b>	
	<b>HOT CYCLE</b>		<b>COLD CYCLE</b>	
Cycle 1	Date In: _____ Time In: _____ Temperature: _____ °C	Date Out: _____ Time Out: _____ Duration: _____ hours	Date In: _____ Time In: _____ Temperature: _____ °C	Date Out: _____ Time Out: _____ Duration: _____ hours
Cycle 2	Date In: _____ Time In: _____ Temperature: _____ °C	Date Out: _____ Time Out: _____ Duration: _____ hours	Date In: _____ Time In: _____ Temperature: _____ °C	Date Out: _____ Time Out: _____ Duration: _____ hours
Cycle 3	Date In: _____ Time In: _____ Temperature: _____ °C	Date Out: _____ Time Out: _____ Duration: _____ hours	Date In: _____ Time In: _____ Temperature: _____ °C	Date Out: _____ Time Out: _____ Duration: _____ hours
Cycle 4	Date In: _____ Time In: _____ Temperature: _____ °C	Date Out: _____ Time Out: _____ Duration: _____ hours	Date In: _____ Time In: _____ Temperature: _____ °C	Date Out: _____ Time Out: _____ Duration: _____ hours
Cycle 5	Date In: _____ Time In: _____ Temperature: _____ °C	Date Out: _____ Time Out: _____ Duration: _____ hours	Date In: _____ Time In: _____ Temperature: _____ °C	Date Out: _____ Time Out: _____ Duration: _____ hours
Cycle 6	Date In: _____ Time In: _____ Temperature: _____ °C	Date Out: _____ Time Out: _____ Duration: _____ hours	Date In: _____ Time In: _____ Temperature: _____ °C	Date Out: _____ Time Out: _____ Duration: _____ hours
Cycle 7	Date In: _____ Time In: _____ Temperature: _____ °C	Date Out: _____ Time Out: _____ Duration: _____ hours	Date In: _____ Time In: _____ Temperature: _____ °C	Date Out: _____ Time Out: _____ Duration: _____ hours
Cycle 8	Date In: _____ Time In: _____ Temperature: _____ °C	Date Out: _____ Time Out: _____ Duration: _____ hours	Date In: _____ Time In: _____ Temperature: _____ °C	Date Out: _____ Time Out: _____ Duration: _____ hours
Cycle 9	Date In: _____ Time In: _____ Temperature: _____ °C	Date Out: _____ Time Out: _____ Duration: _____ hours	Date In: _____ Time In: _____ Temperature: _____ °C	Date Out: _____ Time Out: _____ Duration: _____ hours
Cycle 10	Date In: _____ Time In: _____ Temperature: _____ °C	Date Out: _____ Time Out: _____ Duration: _____ hours	Date In: _____ Time In: _____ Temperature: _____ °C	Date Out: _____ Time Out: _____ Duration: _____ hours

<b>Lifejacket/immersion suit lights</b>	Manufacturer: _____ Model: _____ Lot/Serial Number: _____	Date: _____ Time: _____ Surveyor: _____ Organization: _____
<b>2.2.3.4 Light tests</b>		<b>Regulations: LSA Code 1.2.2.3/2.2.3.1.1/2.2.3.1.2/2.2.3.2.2; MSC.81(70) 1/10.3.2/10.3.5/ 10.3.5.2/10.3.5.3/10.4/10.4.9</b>
Test Procedure	Acceptance Criteria	Significant Test Data
<p>Four lifejacket lights which have passed the temperature cycling test should be taken from a stowage temperature of -30°C and then be operated immersed in seawater at a temperature of -1°C, four lifejacket lights which have passed the temperature cycling test should be taken from a stowage temperature of +65°C and be operated immersed in seawater at a temperature of +30°C, and four lifejacket lights which have passed the temperature cycling test should be taken from ordinary room conditions and be operated immersed in freshwater at ambient temperature.</p> <p>If the voltage at 5 min of operation is lower than the recorded voltage at the end of life it is permissible to use a lamp from the same build standard for the light output test. Using the lowest recorded voltage a light output test can be carried out as described below. The voltage of all 12 test units should be monitored continuously for 8 h. To make sure that all test units provide a luminous intensity of not less than 0.75 cd in all directions of the upper hemisphere for 8 h operation, the following test should be performed.</p>	<p>Water-activated lifejacket lights should commence functioning within 2 min and have reached a luminous intensity of not less than 0.75 cd within 5 min in seawater. In freshwater a luminous intensity of not less than 0.75 cd should have been attained within 10 min. At least 11 out of the 12 lifejacket lights should continue to provide a luminous intensity of not less than 0.75 cd in all directions of the upper hemisphere for a period of at least 8 h.</p> <p>In the case of a flashing light it should be established that the rate of flashing for the 8 h operative period is not less than 50 flashes and not more than 70 flashes per minute and that the effective luminous intensity is at least 0.75 cd in all directions of the upper hemisphere. (See formula below to calculate the effective luminous intensity).</p>	<p><u>Results:</u></p> <p>All luminous intensity data is to be attached here.</p> <p>PASS: _____ FAIL: _____</p> <p>Recorded voltage at the end of life:          Voltage at 5 min of operation:          Lowest recorded voltage:          Details of three lights selected for light output test:          All luminous intensity, hours of operation, flash details, color of light and Voltage data is to be attached here for each light</p> <p>a) Taken from -30°C:          b) Taken from +65°C:          c) Taken from ordinary room conditions:</p> <p>Comments/Observations</p>

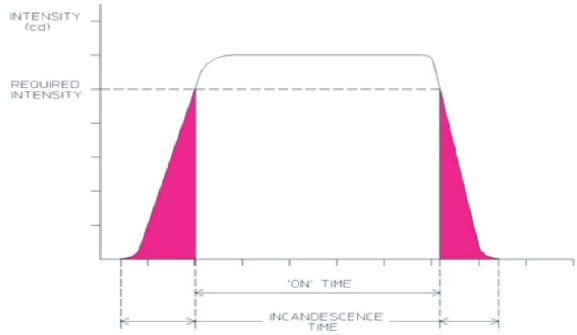

<b>Lifejacket/immersion suit lights</b>	Manufacturer: _____ Model: _____ Lot/Serial Number: _____	Date: _____ Time: _____ Surveyor: _____ Organization: _____
<b>2.2.3.4 Light tests (continued)</b>		<b>Regulations: LSA Code 1.2.2.3/2.2.3.1.1/2.2.3.1.2/2.2.3.2.2; MSC.81(70) 1/10.3.2/10.3.5/ 10.3.5.2/10.3.5.3/10.4/10.4.9</b>
Test Procedure	Acceptance Criteria	Significant Test Data
<p>It must be demonstrated that at least one light from each of the specified temperature ranges reaches the required luminous intensity in all directions of the upper hemisphere when using a photometer which is calibrated to the photometric standards of the appropriate National or State Standard Institute (Note: CIE Publ. No.70 contains further information.). The lowest voltage light of the cold temperature test sample lot, the highest voltage light of the high temperature test sample lot and the mean voltage light of the ambient temperature sample lot should be selected. These three lights must be used for the light output tests. In the event that a lamp filament burns out during the light output test, a second light from the same performance test lot may be used. Luminous intensity should be measured by a photometer directed at the center of the light source with the test light on a rotating table. Luminous intensity should be measured in a horizontal direction at the level of the center of the light source and continuously recorded through a 360° rotation.</p>	<p>The effective luminous intensity is to be found from the formula:</p> $\left[ \frac{\int_{t_1}^{t_2} I dt}{0.2 + (t_2 - t_1)} \right]_{\max}$ <p>where:</p> <p>I is the instantaneous intensity,          0.2 is the Blondel-Rey constant and          t<sub>1</sub> and t<sub>2</sub> are time limits of integration in seconds.</p>	<p>Comments/Observations</p>

<b>Lifejacket/immersion suit lights</b>	Manufacturer: _____ Model: _____ Lot/Serial Number: _____	Date: _____ Time: _____ Surveyor: _____ Organization: _____
<b>2.2.3.4 Light tests (continued)</b>		<b>Regulations: LSA Code 1.2.2.3/2.2.3.1.1/2.2.3.1.2/2.2.3.2.2; MSC.81(70) 1/10.3.2/10.3.5/ 10.3.5.2/10.3.5.3/10.4/10.4.9</b>
Test Procedure	Acceptance Criteria	Significant Test Data
<p>The first measurement should be taken at 0° (horizontal) and should continue to be taken in azimuth angle at 5° intervals to a single measurement at 90° (vertical). Luminous intensity should be measured in a vertical direction, beginning at the center of the light source at the point of lowest recorded light output, and continuously recorded through an arc of 180°. All measured data of luminous intensity and voltage should be documented.</p> <p>After having passed the light tests one light should be subjected to the chromaticity test.</p>	<p>Flashing lights with a flash duration of not less than 0.3 s, may be considered as fixed/steady lights for the measurement of their luminous intensity. Such lights should provide the required luminous intensity in all directions of the upper hemisphere. The time interval between switching on and reaching the required luminous intensity (incandescence time) and all time spent below the required luminous intensity when the light switches off should be disregarded (see figure 10.4.1.)</p> <p>Figure 10.4.1 "On time" measurement diagram</p> 	<p>Comments/Observations</p>

<b>Lifejacket/immersion suit lights</b>	Manufacturer: _____ Model: _____ Lot/Serial Number: _____	Date: _____ Time: _____ Surveyor: _____ Organization: _____
<b>2.2.3.5 Chromaticity test</b>		<b>Regulations: LSA Code 2.2.3.1.4; MSC.81(70) 1/ 10.3.2/10.4/10.4.10</b>
Test Procedure	Acceptance Criteria	Significant Test Data
<p>One lifejacket light which has passed the light tests should be tested for chromaticity to determine that it lies within the boundaries of the area "white" of the diagram specified for each colour by the International Commission on Illumination (CIE).</p> <p>The chromaticities of the lifejacket light should be measured by means of colorimetric measurement equipment which is calibrated to the appropriate National or State Standards Institute (Note: CIE Publ. No.15.2 contains further information). Measurement on at least four points of the upper hemisphere should be taken.</p>	<p>The measured chromaticity coordinates should fall within the boundaries of the area of the diagram as per CIE. The boundaries of the area for white lights are given by the following corner coordinates:</p> <p>x 0.500 0.500 0.440 0.300 0.300 0.440  y 0.382 0.440 0.433 0.344 0.278 0.382</p> <p>(International Standard on Colours of Light Signals, with colour tables to be developed by CIE.)</p>	<p><u>Results:</u>  All chromaticity data is to be attached here. PASS:  FAIL:</p> <p>Comments/Observations</p>

<b>Lifejacket/immersion suit lights</b>	Manufacturer: _____ Model: _____ Lot/Serial Number: _____	Date: _____ Time: _____ Surveyor: _____ Organization: _____	
<b>2.2.3.6 Drop test</b>		<b>Regulations: LSA Code 2.2.1.5.6; MSC.81(70) 1/</b>	<b>10.3.3</b>
Test Procedure	Acceptance Criteria	Significant Test Data	
<p>One lifejacket light which has passed the visual inspection should be attached to a lifejacket and then be subjected to a drop test as follows: Without readjusting the lifejacket, the test subject should jump vertically into the water, feet first, from a height of at least 4.5 m. When jumping into the water, the test subject should hold on to the lifejacket during water entry to avoid possible injury.</p> <p>For the approval of the lifejacket light, the test result obtained from the participating subject should be acceptable except as provided otherwise.</p> <p>After this drop test the light should be taken from ordinary room conditions and operate immersed in freshwater at ambient temperature.</p> <p>The light should then be subjected to the light tests (see 2.2.3.3).</p>	<p>The lifejacket light should not suffer damage, should not be dislodged from the lifejacket, should not injure the wearer, and should be switched on and seen to be illuminated and conspicuous whilst the test subject is still in the water.</p> <p>Water-activated lights should commence functioning within 2 min and have reached a luminous intensity of not less than 0.75cd within 5 min in seawater. In freshwater a luminous intensity of not less than 0.75 cd should have been attained within 10 min. The light should continue to provide a luminous intensity of not less than 0.75 cd in all directions of the upper hemisphere for a period of at least 8 h. (For further details see Light Tests).</p>	<p><u>Results:</u></p> <p>PASS: _____ FAIL: _____</p> <p>Comments/Observations</p>	

<b>Lifejacket/immersion suit lights</b>	Manufacturer: _____ Model: _____ Lot/Serial Number: _____	Date: _____ Time: _____ Surveyor: _____ Organization: _____
<b>2.2.3.7 2 m light drop test</b>		<b>Regulations: MSC.81(70) 1/ 10.3.4</b>
Test Procedure	Acceptance Criteria	Significant Test Data
<p>One lifejacket light which has passed the visual inspection should be dropped from a height of 2 m onto a rigidly mounted steel plate or concrete surface.</p> <p>After this test the light should be taken from ordinary room conditions and operate immersed in freshwater at ambient temperature.</p> <p>The light should be subjected next to the light tests (see 2.2.3.3).</p>	<p>The lifejacket light should not suffer damage and should be capable of providing a luminous intensity of not less than 0.75 cd for a period of at least 8 h when operated immersed in freshwater at ambient temperature. (For further details see Light Tests at 2.2.3.3).</p>	<p><u>Results:</u></p> <p>PASS: _____ FAIL: _____</p> <p>Comments/Observations</p>
<b>2.2.3.8 Switch arrangement test</b>		<b>Regulations: MSC.81(70) 1/ 10.3.5/10.3.5.1/10.4/10.4.3</b>
Test Procedure	Acceptance Criteria	Significant Test Data
<p>If a manual switch is fitted, the switch arrangement test should be carried out.</p> <p>One lifejacket light which has passed the visual inspection should be subjected to the switch arrangement test.</p> <p>A test person wearing immersion suit gloves, must be able to switch the lifejacket light in its normal operational position on and off three times.</p> <p>After having passed the switch arrangement test the light should be subjected next to the vibration test.</p>	<p>The light must function properly.</p>	<p><u>Results:</u></p> <p>PASS: _____ FAIL: _____</p> <p>Comments/Observations</p>

<b>Lifejacket/immersion suit lights</b>	Manufacturer: _____ Model: _____ Lot/Serial Number: _____	Date: _____ Time: _____ Surveyor: _____ Organization: _____
<b>2.2.3.9 Vibration test</b>		<b>Regulations: LSA Code 1.2.2.1/1.2.2.8; MSC.81(70) 1/ 10.4/10.4.1</b>
Test Procedure	Acceptance Criteria	Significant Test Data
<p>The lifejacket light which has passed the switch arrangement test should be subjected to a vibration test according to IEC 60945:2002, paragraph 8.7.</p>	<p>The lifejacket light should be constructed with proper workmanship and materials</p> <p>The lifejacket light should function after the test.</p>	<p><u>Results:</u></p> <p>PASS: _____ FAIL: _____</p> <p>Comments/Observations</p>

<b>Lifejacket/immersion suit lights</b>	Manufacturer: _____ Model: _____ Lot/Serial Number: _____	Date: _____ Time: _____ Surveyor: _____ Organization: _____
<b>2.2.3.10 Mould growth test</b>		<b>Regulations: LSA Code 1.2.2.4; MSC.81(70) 1/ 10.4/10.4.2</b>
Test Procedure	Acceptance Criteria	Significant Test Data
<p>One lifejacket light which has passed the visual inspection should be subjected to the mould growth test. The lifejacket light should be inoculated by spraying with an aqueous suspension of mould spores containing all the following cultures:</p> <p>Aspergillus niger; Aspergillus terreus; Aureobasidium pullulans; Paecilomyces variotii; Penicillium funiculosum, Penicillium ochro-chloron; Scopulariopsis brevicaulis; and Trichoderma viride.</p> <p>The lifejacket light should then be placed in a mould growth chamber which should be maintained at a temperature of 29°C +/- 1°C and a relative humidity of not less than 95 %. The period of incubation should be 28 days. After this period the lifejacket light should be inspected.</p> <p>(Note: The mould growth test may be waived where the manufacturer is able to produce evidence that the external materials employed will satisfy the test.)</p>	<p>The lifejacket light should be rot-proof and not be unduly affected by fungal attack.</p> <p>There should be no mould growth visible to the naked eye and the lifejacket light should function after the test.</p>	<p><u>Results:</u></p> <p>PASS: _____ FAIL: _____</p> <p>Comments/Observations</p>

<b>Lifejacket/immersion suit lights</b>	Manufacturer: _____ Model: _____ Lot/Serial Number: _____	Date: _____ Time: _____ Surveyor: _____ Organization: _____
<b>2.2.3.11 Corrosion and seawater resistance test</b>		<b>Regulations: LSA Code 1.2.2.4; MSC.81(70) 1/ 10.4/10.4.4</b>
Test Procedure	Acceptance Criteria	Significant Test Data
<p>One lifejacket light which has passed the visual inspection should be subjected to a corrosion and seawater resistance test according to IEC 60945:2002, paragraph 8.12.</p> <p>(Note:          .1 If there are no exposed metal parts the Corrosion and Seawater Resistance Test need not be conducted.          .2 The Corrosion and Seawater Resistance Test may be waived where the manufacturer is able to produce evidence that the external metals employed will satisfy the test.          .3 Automatic activated version should be prevented from switching during the test.)          .4 Where the exposed metal is part of the automatic switch sensor, the function test after the 28-day test cannot be done.</p>	<p>The lifejacket light should be corrosion resistant and not be unduly affected by seawater.</p> <p>Furthermore, the lifejacket light should comply with the requirements of IEC 60945:2002 paragraph 8.12.2.</p> <p>There should be no undue deterioration of metal parts and the lifejacket light should function after the test.</p>	<p><u>Results:</u></p> <p>PASS: _____ FAIL: _____</p> <p>Comments/Observations</p>



<b>Lifejacket/immersion suit lights</b>	Manufacturer: _____ Model: _____ Lot/Serial Number: _____	Date: _____ Time: _____ Surveyor: _____ Organization: _____
<b>2.2.3.12 Test for oil resistance</b>		<b>Regulations: LSA Code 1.2.2.4; MSC.81(70) 1/ 10.4/10.4.6</b>
Test Procedure	Acceptance Criteria	Significant Test Data
<p>One lifejacket light which has passed the visual inspection should be subjected to the test for oil resistance according to IEC 60945:2002, paragraph 8.11. Automatic activated version should be prevented from switching during the test.</p>	<p>After this test the lifejacket light should not be unduly affected by oil and should show no sign of damage such as shrinking, cracking, swelling, dissolution or change of mechanical qualities.</p> <p>The lifejacket light should function after the test.</p>	<p><u>Results:</u></p> <p>PASS: _____ FAIL: _____</p> <p>Comments/Observations</p>
<b>2.2.3.13 Rain test and watertightness test</b>		<b>Regulations: LSA Code 1.2.2.4/1.2.2.8; MSC.81(70) 1/ 10.4/10.4.7</b>
Test Procedure	Acceptance Criteria	Significant Test Data
<p>One lifejacket light which has passed the visual inspection should be subjected to a rain test according to IEC 60945:2002, paragraph 8.8.</p> <p>After having passed the rain test the lifejacket light and the complete power source should be immersed horizontally under not less than 300 mm of fresh water for at least 24 h.</p> <p>Automatic activated version should be prevented from switching during the test.</p>	<p>The lifejacket light should be rot-proof</p> <p>The lifejacket light should comply with the requirements of IEC 60945:2002, paragraph 8.8.2 and should function after the rain test.</p> <p>After the water-tightness test the lifejacket light should function and there should be no evidence of water inside the lifejacket light.</p>	<p><u>Results:</u></p> <p>PASS: _____ FAIL: _____</p> <p>Comments/Observations</p>

<b>Lifejacket/immersion suit lights</b>	Manufacturer: _____ Model: _____ Lot/Serial Number: _____	Date: _____ Time: _____ Surveyor: _____ Organization: _____
<b>2.2.3.14 Fire Test</b>		<b>Regulations: LSA Code 2.2.1.1; MSC.81(70) 1/ 10.4/10.4.8</b>
Test Procedure	Acceptance Criteria	Significant Test Data
<p>One lifejacket light which has passed the visual inspection should be subjected to a fire test. A test pan not less than 30 cm x 35 cm x 6 cm should be placed in an essentially draught-free area. Water should be put in the bottom of the test pan to a depth of at least 1 cm followed by enough petrol to make a minimum total depth of not less than 4 cm. The petrol should then be ignited and allowed to burn freely for at least 30 s. The lifejacket light should then be moved through the flames, facing them, with the lifejacket light not more than 25 cm above the top edge of the test pan so that the duration of exposure to the flames is at least 2s.</p>	<p>The lifejacket light should not sustain burning or continue melting after being totally enveloped in a fire for a period of at least 2 s and after being removed from the flames.</p> <p>The lifejacket light should function after the test.</p>	<p><u>Results:</u></p> <p>PASS: _____ FAIL: _____</p> <p>Comments/Observations</p>

**2.2.4 REFERENCE TEST DEVICE (RTD)  
CONSTRUCTION VALIDATION AND CALIBRATION**

- 2.2.4.1 Adult Lifejacket RTD
  - 2.2.4.1.1 Buoyancy calibration
  - 2.2.4.1.2 Construction validation – General
  - 2.2.4.1.3 Construction Validation – Fabric and Webbing measurements
- 2.2.4.2 Child Lifejacket RTD
  - 2.2.4.2.1 Buoyancy calibration
- 2.2.4.3 Infant Lifejacket RTD
  - 2.2.4.3.1 Buoyancy calibration

**2.2.4 REFERENCE TEST DEVICE (RTD)  
CONSTRUCTION VALIDATION AND CALIBRATION**

<b>Manufacturer</b>	
<b>Serial number</b>	
<b>Size (Adult/Child/Infant)</b>	
<b>Date of construction</b>	
<b>Place of construction</b>	
<b>Date of validation/calibration</b>	
<b>Place of validation/calibration</b>	
<b>Signature</b>	

<b>Reference test device (RTD)</b>	Manufacturer: _____ Model: _____ Lot/Serial Number: _____	Date: _____ Time: _____ Surveyor: _____ Organization: _____																					
<b>2.2.4.1.1 Buoyancy calibration</b>		<b>Regulations: LSA Code 2.2.1.4; MSC.81(70) Annex 1, Appendix</b>																					
<b>Test Procedure</b>	<b>Acceptance Criteria</b>																						
<p>To achieve repeatability in human subject testing, the overall buoyancy and distribution of buoyancy between the front and back of the RTD must be maintained within a tight tolerance.</p> <p>The buoyancy of a new RTD may exceed the allowable tolerance range until the normal shrinkage or compression of the foam inserts stabilizes. Until the buoyancies of the foam inserts have stabilized, buoyancy and distribution should be checked at regular intervals (perhaps weekly), and then at least monthly thereafter or whenever used for testing, whichever is longer (frequent use may require more frequent checks). Only RTDs with buoyancies within tolerance should be used for certification testing.</p> <p>At the time of manufacture the left-to-right distribution of buoyancy in the front inserts was adjusted to be within 1.3 N of each other. To achieve this tolerance, thin layers of foam ("make-up" inserts) may have been inserted between the front and inside front foam inserts. The test house may need to increase the size of these make-up inserts from time to time to keep these parameters within tolerance, or may need to add buoyancy to the back or collar inserts (or trim buoyancy, if the back insert has not shrunk as anticipated).</p>	<table border="1" style="width:100%; border-collapse: collapse;"> <thead> <tr> <th style="width:20%;"></th> <th style="width:20%;">Design</th> <th style="width:20%;">Max</th> <th style="width:20%;">Min</th> </tr> </thead> <tbody> <tr> <td>Front Buoyancy<sup>1</sup></td> <td style="text-align:center;">103 N</td> <td style="text-align:center;">107 N</td> <td style="text-align:center;">100 N</td> </tr> <tr> <td>Back Buoyancy</td> <td style="text-align:center;">46 N</td> <td style="text-align:center;">48 N</td> <td style="text-align:center;">45 N</td> </tr> <tr> <td>Total Buoyancy</td> <td style="text-align:center;">149 N</td> <td style="text-align:center;">155 N</td> <td style="text-align:center;">145 N</td> </tr> <tr> <td>Buoyancy Distribution<sup>2</sup></td> <td style="text-align:center;">69% in front</td> <td style="text-align:center;">70.5% in front</td> <td style="text-align:center;">67.5% in front</td> </tr> </tbody> </table> <p><sup>1</sup> values at or corrected to standard temperature and pressure</p> <p><sup>2</sup> buoyancy distribution is calculated by dividing the front buoyancy by the total buoyancy</p> <p>After a full sheet of 6.5 mm thick foam is required in any one of the four major areas, an inside front or back insert probably needs to be replaced. If the front buoyancy is under the minimum value, measure the buoyancy of the right and left sides so that the proper distribution of buoyancy (no more than a 1.3 N difference) between the right and left front panels can be maintained.</p>			Design	Max	Min	Front Buoyancy <sup>1</sup>	103 N	107 N	100 N	Back Buoyancy	46 N	48 N	45 N	Total Buoyancy	149 N	155 N	145 N	Buoyancy Distribution <sup>2</sup>	69% in front	70.5% in front	67.5% in front	<p><b>Significant Test Data</b></p> <p>Left front buoyancy: _____ N</p> <p>Right front buoyancy: _____ N</p> <p>Total front buoyancy: _____ N</p> <p>Total back buoyancy: _____ N</p> <p>Total buoyancy: _____ N</p> <p>Buoyancy distribution: _____ % in front</p> <p>Make-up inserts added/removed:</p> <p>Foam inserts replaced:</p> <p>Comments:</p>
		Design	Max	Min																			
	Front Buoyancy <sup>1</sup>	103 N	107 N	100 N																			
	Back Buoyancy	46 N	48 N	45 N																			
	Total Buoyancy	149 N	155 N	145 N																			
Buoyancy Distribution <sup>2</sup>	69% in front	70.5% in front	67.5% in front																				

<b>Reference test device (RTD)</b>	Manufacturer: _____ Model: _____ Lot/Serial Number: _____	Date: _____ Time: _____ Surveyor: _____ Organization: _____
<b>2.2.4.1.2 Construction validation – General</b>		<b>Regulations: LSA Code 2.2.1.4; MSC.81(70), annex 1, table A.4; MSC.1/Circ.1470, 2.1</b>
<b>Test Procedure</b>	<b>Acceptance Criteria</b>	<b>Significant Test Data</b>
<p>Spot check foam inserts. While it is not necessary to conduct a full check of all the dimensions of the foam, a spot check of one out of every five RTDs should be made of a representative sampling of foam pieces against the dimensions in the appropriate annex to the Revised recommendation on testing of life-saving appliances (resolution MSC.81(70)).</p>	<p>The values should be within <math>\pm 6</math> mm.</p>	<p>a. Front foam insert (figure A.27)              Pass      Fail</p> <p>b. Inside front foam insert (figure A.28)              Pass      Fail</p> <p>c. Collar foam insert (figure A.29)              Pass      Fail</p> <p>d. Back foam insert (figure A.30)              Pass      Fail</p> <p>Comments/observations:</p>

<b>Reference test device (RTD)</b>	Manufacturer: _____ Model: _____ Lot/Serial Number: _____	Date: _____ Time: _____ Surveyor: _____ Organization: _____
<b>2.2.4.1.3 Construction Validation – Fabric and Webbing measurements</b>		<b>Regulations: LSA Code 2.2.1.4; MSC.81(70) Annex 1; MSC.1/Circ.1470, 3</b>
Test Procedure	Acceptance Criteria	Significant Test Data
Establish reference point on the shoulder seam. Place a small mark on the shoulder seam 44.5 mm from the inside edge of the neck seam.	This mark will be the reference point for measuring distances on the front and back panels.	
Vertical webbing. Measure from the reference point to the vertical webbing.	The vertical webbing should be within $\pm 6.5$ mm of this point.	Vertical webbing distance: _____ mm Pass      Fail
Shoulder loop. Measure the distance from the reference point to the location where the inside edge of the yellow webbing first passes under the black shoulder loop.	This distance should be $73 \pm 6$ mm.	Shoulder loop distance: _____ mm Pass      Fail
Chest strap. Measure the distance from the reference point to the top of the chest strap.	This distance should be $168 \pm 6$ mm.	Chest strap distance: _____ mm Pass      Fail
Waist belt. Measure the distance from the reference point to the top of the waist belt.	This distance should be $416 \pm 3$ mm.	Waist belt distance: _____ mm Pass      Fail
Front panel length. Measure the distance from the reference point to the bottom of the foam.	This distance should be $489 \pm 6$ mm.	Front panel length. _____ mm Pass      Fail
Back panel length. Measure the distance from the reference point to the bottom of the back panel.	This distance should be $550 \pm 6$ mm.	Back panel length. _____ mm Pass      Fail

2.2.4.1.3 Construction Validation – Fabric and Webbing measurements		Regulations: LSA Code 2.2.1.4; MSC.81(70) Annex 1; MSC.1/Circ.1470, 3
Test Procedure	Acceptance Criteria	Significant Test Data
Collar attachment location. To check the collar attachment location, hold the RTD by the collar, keeping the collar level so the RTD hangs freely. Measure from the top back edge of the foam down to the centre of the neck seam.	This distance should be $342 \pm 6$ mm.	Collar attachment location: _____ mm Pass      Fail
Webbing attachment to collar. To check the location of the vertical webbing attachment to the collar, measure the distance from the edge of the foam (at the end opposite from the zipper) to the front seams of the box-X stitching.	This distance should be $111 \pm 6$ mm.	Webbing attachment to collar location: _____ mm Pass      Fail
Webbing length (chest strap to collar attachment). To check the length of the vertical webbing from the top of the chest strap to the attachment at the collar, measure the inside distance between the box-X stitches located on the chest strap (front panel) and on the underside of the collar.	This distance should be $263 \pm 6$ mm.	Webbing length: _____ mm Pass      Fail
Finished waist belt assembly length. To check the finished length of the waist belt assembly, measure the overall length with the buckle unfastened and the adjustments in the full open position (maximum length). Lay the RTD on a flat surface and measure the fully extended length of the assembly. For consistency, measure the distance from where the snap hook fastens in the D-Ring.	This distance should be $1700 \pm 12$ mm.	Finished waist belt assembly length: _____ mm Pass      Fail



2.2.4.1.3 Construction Validation – Fabric and Webbing measurements		Regulations: LSA Code 2.2.1.4; MSC.81(70) Annex 1; MSC.1/Circ.1470, 3
Test Procedure	Acceptance Criteria	Significant Test Data
<p>Finished neck size. A suitably sized cone (such as a traffic cone) should be used to check the finished neck size. The cone should be rigid, have a slope of <math>8.5^\circ \pm 1.5^\circ</math>, and be tall enough to allow the RTD to fit snugly. If a flexible cone (such as a plastic traffic safety cone) is used it should be filled with rigid foam, concrete, or similar substance to make it rigid.</p> <p>With both chest and waist belt buckles fastened and the waist belt adjusted to the full open position, place the RTD on the cone with just enough force so it will fit snug to the cone, but not forcing it down.</p> <p>Place a mark on both sides of the cone where the shoulder seam contacts the cone. This mark may be used to facilitate subsequent validations. Measure the circumference around the cone at the mark.</p>	<p>The circumference should be <math>395 \pm 6</math> mm.</p>	<p>Finished neck size: _____ mm</p> <p>Pass      Fail</p>

<b>Reference test device (RTD)</b>	Manufacturer: _____ Model: _____ Lot/Serial Number: _____	Date: _____ Time: _____ Surveyor: _____ Organization: _____			
<b>2.2.4.2.1 Buoyancy calibration</b>		<b>Regulations: LSA Code 2.2.1.4; MSC.81(70) Annex 3, Appendix</b>			
Test Procedure	Acceptance Criteria				
<p>To achieve repeatability in human subject testing, the overall buoyancy and distribution of buoyancy between the front and back of the RTD must be maintained within a tight tolerance.</p> <p>The buoyancy of a new RTD may exceed the allowable tolerance range until the normal shrinkage or compression of the foam inserts stabilizes. Until the buoyancies of the foam inserts have stabilized, buoyancy and distribution should be checked at regular intervals (perhaps weekly), and then at least monthly thereafter or whenever used for testing, whichever is longer (frequent use may require more frequent checks). Only RTDs with buoyancies within tolerance should be used for certification testing.</p> <p>To check buoyancy tolerances, foam inserts need to be removed from the device. Take care that all trapped air is removed when checking buoyancy and that layers are maintained in their proper sequence when reinstalled (considerable effort would be needed to remove entrapped air if testing the intact device).</p>	Design	Max	Min	<p>Left front buoyancy: _____ N</p> <p>Right front buoyancy: _____ N</p> <p>Total front buoyancy: _____ N</p> <p>Total back buoyancy: _____ N</p> <p>Total buoyancy: _____ N</p> <p>Buoyancy distribution: _____ % in front</p> <p>Make-up inserts added/removed:</p> <p>Foam inserts replaced:</p> <p>Comments:</p>	
	Front Buoyancy <sup>1</sup>	63 N	65.4 N		60.6 N
	Back Buoyancy	25 N	26.2 N		23.8 N
	Total Buoyancy	88 N	91.6 N		84.4 N
	Buoyancy Distribution <sup>2</sup>	71.5% in front	73% in front		70% in front
		<p><sup>1</sup> values at or corrected to standard temperature and pressure</p> <p><sup>2</sup> buoyancy distribution is calculated by dividing the front buoyancy by the total buoyancy</p> <p>At the time of manufacture the left-to-right distribution of buoyancy in the front inserts was adjusted to be within 1.3 N of each other. To achieve this tolerance, the layers were individually selected to achieve the cumulative insert buoyancy. If buoyancy of a new device exceeds the upper limits, one layer per compartment may be altered or replaced to bring the unit into compliance. The test house may need to add make -up layers from time to time to maintain the front-to-back and side-to-side insert tolerances. If the front buoyancy is under the minimum value, measure the buoyancy of the right and left sides so that the proper distribution of buoyancy (no more than a 1.3 N difference) between the right and left front panels can be maintained.</p>			

<b>Infant Lifejacket Reference test device (RTD)</b>	Manufacturer: _____ Model: _____ Lot/Serial Number: _____	Date: _____ Time: _____ Surveyor: _____ Organization: _____																				
<b>2.2.4.3.1 Buoyancy calibration</b>		<b>Regulations: LSA Code 2.2.1.4; MSC.81(70) Annex 3, Appendix</b>																				
<b>Test Procedure</b>	<b>Acceptance Criteria</b>																					
<p>To achieve repeatability in human subject testing, the overall buoyancy and distribution of buoyancy between the front and back of the RTD must be maintained within a tight tolerance.</p> <p>The buoyancy of a new RTD may exceed the allowable tolerance range until the normal shrinkage or compression of the foam inserts stabilizes. Until the buoyancies of the foam inserts have stabilized, buoyancy and distribution should be checked at regular intervals (perhaps weekly), and then at least monthly thereafter or whenever used for testing, whichever is longer (frequent use may require more frequent checks). Only RTDs with buoyancies within tolerance should be used for certification testing.</p> <p>To check buoyancy tolerances, foam inserts need to be removed from the device. Take care that all trapped air is removed when checking buoyancy and that layers are maintained in their proper sequence when reinstalled (considerable effort would be needed to remove entrapped air if testing the intact device).</p>	<table border="1" style="width:100%; border-collapse: collapse; margin-bottom: 10px;"> <thead> <tr> <th style="width:30%;"></th> <th style="width:15%;">Design</th> <th style="width:15%;">Max</th> <th style="width:15%;">Min</th> </tr> </thead> <tbody> <tr> <td>Front Buoyancy<sup>1</sup></td> <td>42 N</td> <td>44.4 N</td> <td>39.6 N</td> </tr> <tr> <td>Back Buoyancy</td> <td>29 N</td> <td>30.2 N</td> <td>27.8 N</td> </tr> <tr> <td>Total Buoyancy</td> <td>71 N</td> <td>74.6 N</td> <td>67.4 N</td> </tr> <tr> <td>Buoyancy Distribution<sup>2</sup></td> <td>59.2 % in front</td> <td>60.7 % in front</td> <td>57.7 % in front</td> </tr> </tbody> </table> <p><sup>1</sup> values at or corrected to standard temperature and pressure</p> <p><sup>2</sup> buoyancy distribution is calculated by dividing the front buoyancy by the total buoyancy</p> <p>At the time of manufacture the left-to-right distribution of buoyancy in the front inserts was adjusted to be within 1.3 N of each other. To achieve this tolerance, the layers were individually selected to achieve the cumulative insert buoyancy. If buoyancy of a new device exceeds the upper limits, one layer per compartment may be altered or replaced to bring the unit into compliance. The test house may need to add make -up layers from time to time to maintain the front-to-back and side -to-side insert tolerances. If the front buoyancy is under the minimum value, measure the buoyancy of the right and left sides so that the proper distribution of buoyancy (no more than a 1.3 N difference) between the right and left front panels can be maintained.</p>			Design	Max	Min	Front Buoyancy <sup>1</sup>	42 N	44.4 N	39.6 N	Back Buoyancy	29 N	30.2 N	27.8 N	Total Buoyancy	71 N	74.6 N	67.4 N	Buoyancy Distribution <sup>2</sup>	59.2 % in front	60.7 % in front	57.7 % in front
	Design	Max	Min																			
Front Buoyancy <sup>1</sup>	42 N	44.4 N	39.6 N																			
Back Buoyancy	29 N	30.2 N	27.8 N																			
Total Buoyancy	71 N	74.6 N	67.4 N																			
Buoyancy Distribution <sup>2</sup>	59.2 % in front	60.7 % in front	57.7 % in front																			
	<b>Significant Test Data</b>																					
	<p>Left front buoyancy: _____ N</p> <p>Right front buoyancy: _____ N</p> <p>Total front buoyancy: _____ N</p> <p>Total back buoyancy: _____ N</p> <p>Total buoyancy: _____ N</p> <p>Buoyancy distribution: _____ % in front</p> <p>Make-up inserts added/removed:</p> <p>Foam inserts replaced:</p> <p>Comments:</p>																					

## **2.3 IMMERSION SUITS AND ASSOCIATED EQUIPMENT**

### **2.3.1 IMMERSION SUITS (NON-INSULATED)**

#### **EVALUATION AND TEST REPORT**

- 2.3.1.1 General data and specifications
- 2.3.1.2 Submitted drawings, reports and documents
- 2.3.1.3 Quality assurance
- 2.3.1.4 Visual inspection
- 2.3.1.5 Test subjects
- 2.3.1.6 Test with a lifejacket
- 2.3.1.7 Test clothing
- 2.3.1.8 Donning tests 1 & 2
- 2.3.1.9 Ergonomic test
- 2.3.1.10 Field of vision test
- 2.3.1.11 Flotation test
- 2.3.1.12 Righting test
- 2.3.1.13 Water ingress and jump test
- 2.3.1.14 Jump test
- 2.3.1.15 Leak test
- 2.3.1.16 Swimming and water emergence test
- 2.3.1.17 Oil resistance test
- 2.3.1.18 Alternative oil resistance test
- 2.3.1.19 Fire test
- 2.3.1.20 Temperature cycling test
- 2.3.1.21 Temperature cycling test – Test data
- 2.3.1.22 Buoyancy test
- 2.3.1.23 Strength test
- 2.3.1.24 Thermal protective test (General)
- 2.3.1.25 Thermal protective test (Continued)
- 2.3.1.26 Test sheets for temperatures during immersion tests

**2.3.1 IMMERSION SUITS (NON-INSULATED)  
EVALUATION AND TEST REPORT**

<b>Manufacturer</b>	
<b>Type</b>	
<b>Date</b>	
<b>Place</b>	
<b>Name Surveyor printed</b>	
<b>Signature</b>	
<b>Approving Organization</b>	

<b>Immersion suits (non-isolated)</b>	Manufacturer: _____ Model: _____ Lot/Serial Number: _____	Date: _____ Time: _____ Surveyor: _____ Organization: _____
<b>2.3.1.1 General data and specifications</b>		<b>Regulations: LSA Code II/2.3; MSC.81(70) I/3.1 &amp; 3.2</b>
<b>Construction Material:</b>  Fabric produced by: _____  Type: _____  Buoyant material produced by: _____  Type: _____	<b>Additional equipment:</b>  Retro reflective material produced by: _____ Type: _____  Whistle produced by (if fitted): _____ Type: _____  Life-line produced by (if fitted): _____ Type _____  Light produced by (if fitted): _____ Type: _____	<b>Donning instructions:</b>  <input type="checkbox"/> YES <input type="checkbox"/> NO

<b>Immersion suits (non-isolated)</b>		Manufacturer: _____ Model: _____ Lot/Serial Number: _____	Date: _____ Time: _____ Surveyor: _____ Organization: _____
<b>2.3.1.2 Submitted drawings, reports and documents</b>			
<b>Submitted drawings and documents</b>			<b>Status</b>
<b>Drawing No.</b>	<b>Revision No. &amp; date</b>	<b>Title of drawing</b>	
<b>Submitted reports and documents</b>			<b>Status</b>
<b>Report/Document No.</b>	<b>Revision No. &amp; date</b>	<b>Title of report / document</b>	
		Maintenance Manual -	
		Operations Manual -	

<b>Immersion suits (non-isolated)</b>	Manufacturer: _____ Model: _____ Lot/Serial Number: _____	Date: _____ Time: _____ Surveyor: _____ Organization: _____
<b>2.3.1.3 Quality assurance</b>	<b>Regulations: - MSC.81(70) 2/1.1, 1.2</b>	
<p>Except where all appliances of a particular type are required by chapter III of the International Convention for the Safety of Life at Sea, 1974, as amended, or the international Life-Saving Appliance (LSA) Code, to be inspected, representatives of the Administration should make random inspections of manufacturers to ensure that the quality of life-saving appliances and materials used comply with the specification of the approved prototype life-saving appliance.</p> <p>Manufacturers should be required to institute a quality control procedure to ensure that life-saving appliances are produced to the same standard as the prototype life- saving appliance approved by the Administration and to keep records of any production tests carried out in accordance with the Administration's instructions.</p>	<p>Quality Assurance</p> <p>Standard Used: _____</p> <p>Quality Assurance Procedure: _____</p> <p>Quality Assurance Manual: _____</p> <p>Description of System:</p> <p>Quality Assurance System acceptable Yes _____ No _____</p> <p>Comments/Observations</p>	



<b>Immersion suits (non-isolated)</b>	Manufacturer: _____ Model: _____ Lot/Serial Number: _____	Date: _____ Time: _____ Surveyor: _____ Organization: _____
<b>2.3.1.4 Visual inspection</b>		<b>Regulations: LSA Code I/1.2.2, II/2.3.1.1.3 &amp; 2.3.1.1.4</b>
Test Procedure	Acceptance Criteria	Significant Test Data
<p>Non-insulated immersion suit should:</p> <p>.1 be clearly marked with approval information including the Administration which approved it, date of manufacturer and any operational restrictions;</p> <p>.2 be provided with labels giving operating instructions, general information and manufacturers details as appropriate; and</p> <p>.3 be fitted with approved patches of retro-reflective material with a total area of at least 400 cm<sup>2</sup> and with 100 cm<sup>2</sup> on the back if the suit does not automatically turn the wearer face up according to resolution A.658(16).</p>		<p>Passed _____      Failed _____</p> <p>Passed _____      Failed _____</p> <p>Passed _____      Failed _____</p> <p>Comments/Observations</p>

<b>Immersion suits (non-isolated)</b>	Manufacturer: _____ Model: _____ Lot/Serial Number: _____	Date: _____ Time: _____ Surveyor: _____ Organization: _____
<b>2.3.1.4 Visual inspection (Continued)</b>		
<b>Regulations: LSA Code I/1.2.2, II/2.3.1.1.3 &amp; 2.3.1.1.4, 2.3.1.4, 2.3.1.5, 2.13.1.6</b>		
Test Procedure	Acceptance Criteria	Significant Test Data
<p>Does the non-insulated immersion suit cover the whole body with the exception of the face?</p> <p>Are the hands covered, or is the non-insulated immersion suit equipped with permanently attached gloves?</p> <p>Are their arrangements to prevent excessive free air in the legs?</p> <p>Is the non-insulated immersion suit of highly visible colour?</p> <p>Is the non-insulated immersion suit designed to be worn without a lifejacket? If yes</p> <p>Is the non-insulated immersion suit fitted with a light complying with paragraph 2.2.3 of the LSA Code?</p> <p>Is the non-insulated immersion suit fitted with a whistle complying with paragraph 2.2.1.14 of the LSA Code?</p> <p>Fitted with releasable buoyant lifeline or other means to secure it to a suit worn by another person in the water and provided with a suitable means to allow rescuer to lift the wearer from the water into survival or rescue craft.</p>	<p>Be of an international or vivid reddish orange, or a comparably highly visible colour on all parts where this will assist detection at sea.</p>	<p>Passed _____ Failed _____</p> <p>Passed _____ Failed _____</p> <p>Passed _____ Failed _____</p> <p>Passed _____ Failed _____</p> <p>Passed _____ Failed _____</p> <p>Passed _____ Failed _____</p> <p>Passed _____ Failed _____</p> <p>Passed _____ Failed _____</p> <p>Passed _____ Failed _____</p> <p>Comments/Observations</p>

<b>Immersion suits (non-isolated)</b>	Manufacturer: _____ Model: _____ Lot/Serial Number: _____	Date: _____ Time: _____ Surveyor: _____ Organization: _____																																
<b>2.3.1.5 Test subjects</b>																																		
<b>Regulations: LSA Code II/2.3.1.1.5, 2.3.1.3.1 - .4; MSC.81(70) 1/3.1.1 &amp; 2.8.2</b>																																		
Test Procedure	Acceptance Criteria	Significant Test Data																																
At least six able-bodied persons both male and females of the following heights and weights should be used. At least one and not more than two of the persons should be females with not more than one female in the same height range.	<table style="width:100%; border-collapse: collapse;"> <thead> <tr> <th style="text-align: center;"><u>Height</u></th> <th style="text-align: center;"><u>Weight</u></th> </tr> </thead> <tbody> <tr> <td style="text-align: center;">1.4m - 1.6m;</td> <td style="text-align: center;">1 person under 60kg 1 person over 60kg</td> </tr> <tr> <td style="text-align: center;">1.6m - 1.8m</td> <td style="text-align: center;">1 person under 70kg 1 person over 70kg</td> </tr> <tr> <td style="text-align: center;">over 1.8m</td> <td style="text-align: center;">1 person under 80kg 1 person over 80kg</td> </tr> </tbody> </table>	<u>Height</u>	<u>Weight</u>	1.4m - 1.6m;	1 person under 60kg 1 person over 60kg	1.6m - 1.8m	1 person under 70kg 1 person over 70kg	over 1.8m	1 person under 80kg 1 person over 80kg	<table style="width:100%; border-collapse: collapse;"> <thead> <tr> <th style="text-align: center;"><u>Male/Female</u></th> <th style="text-align: center;"><u>Height</u></th> <th style="text-align: center;"><u>Weight</u></th> </tr> </thead> <tbody> <tr> <td style="text-align: center;">Subject No.1 _____</td> <td style="text-align: center;">_____</td> <td style="text-align: center;">_____</td> </tr> <tr> <td style="text-align: center;">Subject No.2 _____</td> <td style="text-align: center;">_____</td> <td style="text-align: center;">_____</td> </tr> <tr> <td style="text-align: center;">Subject No.3 _____</td> <td style="text-align: center;">_____</td> <td style="text-align: center;">_____</td> </tr> <tr> <td style="text-align: center;">Subject No.4 _____</td> <td style="text-align: center;">_____</td> <td style="text-align: center;">_____</td> </tr> <tr> <td style="text-align: center;">Subject No.5 _____</td> <td style="text-align: center;">_____</td> <td style="text-align: center;">_____</td> </tr> <tr> <td style="text-align: center;">Subject No.6 _____</td> <td style="text-align: center;">_____</td> <td style="text-align: center;">_____</td> </tr> <tr> <td colspan="3" style="padding-top: 10px;">Comments/Observations</td> </tr> </tbody> </table>	<u>Male/Female</u>	<u>Height</u>	<u>Weight</u>	Subject No.1 _____	_____	_____	Subject No.2 _____	_____	_____	Subject No.3 _____	_____	_____	Subject No.4 _____	_____	_____	Subject No.5 _____	_____	_____	Subject No.6 _____	_____	_____	Comments/Observations		
<u>Height</u>	<u>Weight</u>																																	
1.4m - 1.6m;	1 person under 60kg 1 person over 60kg																																	
1.6m - 1.8m	1 person under 70kg 1 person over 70kg																																	
over 1.8m	1 person under 80kg 1 person over 80kg																																	
<u>Male/Female</u>	<u>Height</u>	<u>Weight</u>																																
Subject No.1 _____	_____	_____																																
Subject No.2 _____	_____	_____																																
Subject No.3 _____	_____	_____																																
Subject No.4 _____	_____	_____																																
Subject No.5 _____	_____	_____																																
Subject No.6 _____	_____	_____																																
Comments/Observations																																		

<b>Immersion suits (non-isolated)</b>	Manufacturer: _____ Model: _____ Lot/Serial Number: _____	Date: _____ Time: _____ Surveyor: _____ Organization: _____
<b>2.3.1.6 Test with a lifejacket Regulations: LSA Code II/2.3.1.5; MSC.81(70) 1/3.1.2</b>		
Test Procedure	Acceptance Criteria	Significant Test Data
<p>If the suit is to be worn in conjunction with a lifejacket, the lifejacket should be worn over the suit for the tests prescribed in 2.3.1.8 to 2.3.1.16.</p>		Manufacturer of lifejacket: _____ Type: _____  Manufacturer of lifejacket: _____ Type: _____  Manufacturer of lifejacket: _____ Type: _____  _____ Comments/Observations
<b>2.3.1.7 Test clothing Regulations: LSA Code II/2.3.1.1.1; MSC.81(70) 1/3.2.6 to 3.2.8</b>		
Test Procedure	Acceptance Criteria	Significant Test Data
<p>The test subjects should wear a standard range clothing consisting of</p> <ol style="list-style-type: none"> <li>.1 underwear (short sleeved, short legged)</li> <li>.2 shirt (long sleeved)</li> <li>.3 trousers (not woollen, and</li> <li>.4 woollen socks</li> <li>.5 in addition to the clothing the test subject should wear two woollen pullovers during the thermal protective tests.</li> <li>.6 If suit is to be worn in conjunction with a lifejacket, the lifejacket should be worn during the thermal protective tests.</li> </ol>		<p>Did all test subject use the specified test clothing</p> <p><input type="checkbox"/> YES <input type="checkbox"/> NO</p> Comments/Observations

<b>Immersion suits (non-isolated)</b>	Manufacturer: _____ Model: _____ Lot/Serial Number: _____	Date: _____ Time: _____ Surveyor: _____ Organization: _____																												
<b>2.3.1.8 Donning test (1)</b>		<b>Regulations: LSA Code II/2.3.1.1.1; MSC.81(70) 1/3.1.3</b>																												
Test Procedure	Acceptance Criteria	Significant Test Data																												
<p>Following a demonstration, each test subject should be able to unpack, don and secure the immersion suit over their test clothing without assistance in less than 2 min. This time should include the time to don any associated clothing, inflate any orally inflated chambers if fitted and don a lifejacket, if such is to be worn in conjunction with the immersion suit, and the test subjects should be able to don such lifejacket without assistance.</p>	<p>Each test subjects should be able to unpack, don and secure the immersion suit over their test clothing (see 2.3.1.7) without assistance in less than 2 min. This time should include the time to don any associated clothing, inflate any orally inflated chambers if fitted, and don a lifejacket, if such is to be worn in conjunction with the immersion suit.</p>	<p style="text-align: center;"><u>Donning time</u></p> <table border="0" style="width: 100%;"> <tr> <td style="width: 60%;"></td> <td style="width: 15%; text-align: center;">Time</td> <td style="width: 10%; text-align: center;">Pass</td> <td style="width: 15%; text-align: center;">Fail</td> </tr> <tr> <td>Subject No.1 _____</td> <td>sec</td> <td></td> <td></td> </tr> <tr> <td>Subject No.2 _____</td> <td>sec</td> <td></td> <td></td> </tr> <tr> <td>Subject No.3 _____</td> <td>sec</td> <td></td> <td></td> </tr> <tr> <td>Subject No.4 _____</td> <td>sec</td> <td></td> <td></td> </tr> <tr> <td>Subject No.5 _____</td> <td>sec</td> <td></td> <td></td> </tr> <tr> <td>Subject No.6 _____</td> <td>sec</td> <td></td> <td></td> </tr> </table> <p>Comments/Observations</p>		Time	Pass	Fail	Subject No.1 _____	sec			Subject No.2 _____	sec			Subject No.3 _____	sec			Subject No.4 _____	sec			Subject No.5 _____	sec			Subject No.6 _____	sec		
	Time	Pass	Fail																											
Subject No.1 _____	sec																													
Subject No.2 _____	sec																													
Subject No.3 _____	sec																													
Subject No.4 _____	sec																													
Subject No.5 _____	sec																													
Subject No.6 _____	sec																													
<b>2.3.1.8 Donning test (2)</b>		<b>Regulations: LSA Code I/2.3.1.1.1; MSC.81(70) 1/3.1.4</b>																												
Test Procedure	Acceptance Criteria	Significant Test Data																												
<p>The immersion suit should be capable of being donned in 5 min at an ambient temperature as low as -30° C. Before the donning test the packed immersion suit should be kept in a refrigerated chamber at a temperature of -30° C for 24 h.</p>	<p>The test subject should be able to complete this task in 5 min.</p>	<p style="text-align: center;">Donning time at - 30° C</p> <table border="0" style="width: 100%;"> <tr> <td style="width: 60%;"></td> <td style="width: 15%; text-align: center;">Time</td> <td style="width: 10%; text-align: center;">Passed</td> <td style="width: 15%; text-align: center;">Failed</td> </tr> <tr> <td>Subject No.1 _____</td> <td>sec</td> <td></td> <td></td> </tr> <tr> <td>Subject No.2 _____</td> <td>sec</td> <td></td> <td></td> </tr> <tr> <td>Subject No.3 _____</td> <td>sec</td> <td></td> <td></td> </tr> <tr> <td>Subject No.4 _____</td> <td>sec</td> <td></td> <td></td> </tr> <tr> <td>Subject No.5 _____</td> <td>sec</td> <td></td> <td></td> </tr> <tr> <td>Subject No.6 _____</td> <td>sec</td> <td></td> <td></td> </tr> </table> <p>Comments/Observations</p>		Time	Passed	Failed	Subject No.1 _____	sec			Subject No.2 _____	sec			Subject No.3 _____	sec			Subject No.4 _____	sec			Subject No.5 _____	sec			Subject No.6 _____	sec		
	Time	Passed	Failed																											
Subject No.1 _____	sec																													
Subject No.2 _____	sec																													
Subject No.3 _____	sec																													
Subject No.4 _____	sec																													
Subject No.5 _____	sec																													
Subject No.6 _____	sec																													

<b>Immersion suits (non-isolated)</b>	Manufacturer: _____ Model: _____ Lot/Serial Number: _____	Date: _____ Time: _____ Surveyor: _____ Organization: _____
<b>2.3.1.9 Ergonomic Test</b>		<b>Regulations: LSA Code II/2.3.1.3.1, 2.3.1.3.2; MSC.81(70) 1/3.1.5</b>
<b>Test Procedure</b>	<b>Acceptance Criteria</b>	<b>Significant Test Data</b>
<p>When wearing the immersion suit, the test subjects should be able to:</p> <p>.1 climb up and down a vertical ladder of at least 5 m in length;</p> <p>.2 perform all duties associated with abandonment; and</p> <p>.3 to pick up a pencil and write.</p>	<p>There should be no restriction in walking, bending over or arm movement. The diameter of the pencil should be 8-10 mm.</p>	<p>Restriction in walking, bending over or arm movement:</p> <p><input type="checkbox"/> YES      <input type="checkbox"/> NO</p> <p>All the test subjects were able to pick up a pencil and write:</p> <p><input type="checkbox"/> YES      <input type="checkbox"/> NO</p> <p>All the test subjects were able to put on the lifejacket without assistance:</p> <p><input type="checkbox"/> YES      <input type="checkbox"/> NO</p> <p>All the test subjects were able to perform all duties associated with abandonment, assist others and operate a rescue boat:</p> <p><input type="checkbox"/> YES      <input type="checkbox"/> NO</p> <p>All the test subjects were able to climb up and down a vertical ladder of 5 meter in length:</p> <p><input type="checkbox"/> YES      <input type="checkbox"/> NO</p> <p>Comments/Observations</p>

<b>Immersion suits (non-isolated)</b>	Manufacturer: _____ Model: _____ Lot/Serial Number: _____	Date: _____ Time: _____ Surveyor: _____ Organization: _____			
<b>2.3.1.10 Field of vision test</b>	<b>Regulations: LSA Code II/2.3.1.1.3; MSC.81(70) 1/3.1.6</b>				
Test Procedure	Acceptance Criteria	Significant Test Data			
Each test subject should be seated with the head in a fixed position, and the lateral field of vision measured.	The lateral field of vision should be at least 120°.	Field of vision angle: ≥ 120°			
		Subject No.1 Subject No.2 Subject No.3 Subject No.4 Subject No.5 Subject No.6	Passed	Failed	
			Comments/Observations		
<b>2.3.1.11 Flotation test</b>	<b>Regulations: LSA Code II/2.3.1.1; MSC.81(70) 1/3.1.7</b>				
Test Procedure	Acceptance Criteria	Significant Test Data			
With the test subject floating at rest, wearing the suit in conjunction with a lifejacket if required, the freeboard should be measured from the water surface to the nose or mouth.	The test subject should float face-up with their mouths clear of the water by at least 120mm and be stable in that position.  The position of the lifejacket light should permit it to be visible over as great a segment of the upper hemisphere as is practicable.	Subject No.1 Subject No.2 Subject No.3 Subject No.4 Subject No.5 Subject No.6	Mouth Freeboard	Nose Freeboard	Light Position ok? (Y/N)
			Comments/Observations		

<b>Immersion suits (non-isolated)</b>	Manufacturer: _____ Model: _____ Lot/Serial Number: _____	Date: _____ Time: _____ Surveyor: _____ Organization: _____
<b>2.3.1.12 Righting test</b>		<b>Regulations: LSA Code II/2.3.1.2; MSC.81(70) 1/3.1.8</b>
Test Procedure	Acceptance Criteria	Significant Test Data
The test subjects in fresh water wearing either a non-insulated immersion suit or a non-insulated immersion suit with a lifejacket should each demonstrate that they can turn themselves from a face-down to a face-up position in not more than 5 s.	Except where it has been demonstrated that the non-insulated immersion suit will right the test subjects within 5 s, the test subjects should each demonstrate that they can turn themselves from a face-down to a face-up position in not more than 5 s.	<p style="text-align:center">Passed Failed</p> Subject No.1      _____      _____ Subject No.2      _____      _____ Subject No.3      _____      _____ Subject No.4      _____      _____ Subject No.5      _____      _____ Subject No.6      _____      _____ Comments/Observations      _____      _____
<b>2.3.1.13 Water ingress and jump test</b>		<b>Regulations: MSC.81(70) 1/3.1.9</b>
Test Procedure	Acceptance Criteria	Significant Test Data
The test subjects should pre-wet their non-insulated immersion suit and then be weighed. Following a jump into the water from a height sufficient to totally immerse the body, each test subject should be weighed again.  Weighing should be performed on a machine accurate to ± 100g.	The difference in the combined mass of the test subject and the suit should not exceed 500 g.	<p style="text-align:center">Mass difference ≤ 500g</p> <p style="text-align:center">Pass    Fail</p> Subject No.1      _____      _____ Subject No.2      _____      _____ Subject No.3      _____      _____ Subject No.4      _____      _____ Subject No.5      _____      _____ Subject No.6      _____      _____ Comments/Observations      _____      _____



<b>Immersion suits (non-isolated)</b>	Manufacturer: _____ Model: _____ Lot/Serial Number: _____	Date: _____ Time: _____ Surveyor: _____ Organization: _____																								
<b>2.3.1.14 Jump test</b>		<b>Regulations: LSA Code II/2.3.1.3.3; MSC.81(70) 1/3.1.10</b>																								
Test Procedure	Acceptance Criteria	Significant Test Data																								
<p>The test subjects should jump with the suit and lifejacket if required from a height of 4.5m vertically into the water. After the jump, the suit and its attachments should be examined for damage or dislodging, and the test subject should be questioned concerning whether the suit caused any injury to the wearer.</p>	<p>The suit and its attachments should not be damaged or dislodged in any way. The test subject should not be injured by the suit.</p>	<table border="0"> <tr> <td></td> <td style="text-align: center;">Passed</td> <td style="text-align: center;">Failed</td> </tr> <tr> <td>Subject No.1</td> <td style="text-align: center;">_____</td> <td style="text-align: center;">_____</td> </tr> <tr> <td>Subject No.2</td> <td style="text-align: center;">_____</td> <td style="text-align: center;">_____</td> </tr> <tr> <td>Subject No.3</td> <td style="text-align: center;">_____</td> <td style="text-align: center;">_____</td> </tr> <tr> <td>Subject No.4</td> <td style="text-align: center;">_____</td> <td style="text-align: center;">_____</td> </tr> <tr> <td>Subject No.5</td> <td style="text-align: center;">_____</td> <td style="text-align: center;">_____</td> </tr> <tr> <td>Subject No.6</td> <td style="text-align: center;">_____</td> <td style="text-align: center;">_____</td> </tr> <tr> <td colspan="3">Comments/Observations</td> </tr> </table>		Passed	Failed	Subject No.1	_____	_____	Subject No.2	_____	_____	Subject No.3	_____	_____	Subject No.4	_____	_____	Subject No.5	_____	_____	Subject No.6	_____	_____	Comments/Observations		
	Passed	Failed																								
Subject No.1	_____	_____																								
Subject No.2	_____	_____																								
Subject No.3	_____	_____																								
Subject No.4	_____	_____																								
Subject No.5	_____	_____																								
Subject No.6	_____	_____																								
Comments/Observations																										
<b>2.3.1.15 Leak test</b>		<b>Regulations: LSA Code II/2.3.1.1.1; MSC.81(70) 1/3.1.11</b>																								
Test Procedure	Acceptance Criteria	Significant Test Data																								
<p>The test subject should pre-wet the immersion suit and be weighed. The test subject should then be instructed to do one of the following:</p> <ol style="list-style-type: none"> <li>.1 a period of flotation in calm water of 1h; or</li> <li>.2 swimming for 20 min for a distance of at least 200 m</li> </ol> <p>The test subject should be weighed again after the task.</p> <p>The weighing machine should be accurate to <math>\pm 100g</math>.</p>	<p>The ingress of water into the pre-wetted suit should not exceed a mass of 200g.</p>	<p>Indicate which alternative is used. <input type="checkbox"/>Alternative 1 <input type="checkbox"/>Alternative 2</p> <p>Water ingress <math>\leq 200g</math></p> <table border="0"> <tr> <td></td> <td style="text-align: center;">Passed</td> <td style="text-align: center;">Failed</td> </tr> <tr> <td>Subject No.1</td> <td style="text-align: center;">_____</td> <td style="text-align: center;">_____</td> </tr> <tr> <td>Subject No.2</td> <td style="text-align: center;">_____</td> <td style="text-align: center;">_____</td> </tr> <tr> <td>Subject No.3</td> <td style="text-align: center;">_____</td> <td style="text-align: center;">_____</td> </tr> <tr> <td>Subject No.4</td> <td style="text-align: center;">_____</td> <td style="text-align: center;">_____</td> </tr> <tr> <td>Subject No.5</td> <td style="text-align: center;">_____</td> <td style="text-align: center;">_____</td> </tr> <tr> <td>Subject No.6</td> <td style="text-align: center;">_____</td> <td style="text-align: center;">_____</td> </tr> <tr> <td colspan="3">Comments/Observations</td> </tr> </table>		Passed	Failed	Subject No.1	_____	_____	Subject No.2	_____	_____	Subject No.3	_____	_____	Subject No.4	_____	_____	Subject No.5	_____	_____	Subject No.6	_____	_____	Comments/Observations		
	Passed	Failed																								
Subject No.1	_____	_____																								
Subject No.2	_____	_____																								
Subject No.3	_____	_____																								
Subject No.4	_____	_____																								
Subject No.5	_____	_____																								
Subject No.6	_____	_____																								
Comments/Observations																										

<b>Immersion suits (non-isolated)</b>	Manufacturer: _____ Model: _____ Lot/Serial Number: _____	Date: _____ Time: _____ Surveyor: _____ Organization: _____																																																															
<b>2.3.1.16 Swimming and water emergence test</b>		<b>Regulations: LSA Code II/2.3.1.3.4; MSC.81(70) 1/3.1.12</b>																																																															
Test Procedure	Acceptance Criteria	Significant Test Data																																																															
<p>All test subjects, each wearing a lifejacket but not the suit, should attempt to swim 25 m and board a liferaft or rigid platform with its surface 300 mm above the water surface.</p> <p>Test subjects who successfully complete this task should also perform it wearing the suit.</p> <p>If designed to be used with a lifejacket, then non-insulated immersion suit should be tested with the subject also wearing a lifejacket.</p>	<p>All qualified test subjects should be able to board the liferaft or platform while wearing the non-insulated immersion suit.</p>	<p>1) 25m swim and boarding without lifejacket.</p> <table style="width:100%; border-collapse: collapse;"> <thead> <tr> <th style="width:60%;"></th> <th style="width:20%; text-align: center;">Passed</th> <th style="width:20%; text-align: center;">Failed</th> </tr> </thead> <tbody> <tr><td>Subject No.1</td><td style="text-align: center;">_____</td><td style="text-align: center;">_____</td></tr> <tr><td>Subject No.2</td><td style="text-align: center;">_____</td><td style="text-align: center;">_____</td></tr> <tr><td>Subject No.3</td><td style="text-align: center;">_____</td><td style="text-align: center;">_____</td></tr> <tr><td>Subject No.4</td><td style="text-align: center;">_____</td><td style="text-align: center;">_____</td></tr> <tr><td>Subject No.5</td><td style="text-align: center;">_____</td><td style="text-align: center;">_____</td></tr> <tr><td>Subject No.6</td><td style="text-align: center;">_____</td><td style="text-align: center;">_____</td></tr> </tbody> </table> <p>2) 25 m swim and boarding with suit</p> <table style="width:100%; border-collapse: collapse;"> <thead> <tr> <th style="width:60%;"></th> <th style="width:20%; text-align: center;">Passed</th> <th style="width:20%; text-align: center;">Failed</th> </tr> </thead> <tbody> <tr><td>Subject No.1</td><td style="text-align: center;">_____</td><td style="text-align: center;">_____</td></tr> <tr><td>Subject No.2</td><td style="text-align: center;">_____</td><td style="text-align: center;">_____</td></tr> <tr><td>Subject No.3</td><td style="text-align: center;">_____</td><td style="text-align: center;">_____</td></tr> <tr><td>Subject No.4</td><td style="text-align: center;">_____</td><td style="text-align: center;">_____</td></tr> <tr><td>Subject No.5</td><td style="text-align: center;">_____</td><td style="text-align: center;">_____</td></tr> <tr><td>Subject No.6</td><td style="text-align: center;">_____</td><td style="text-align: center;">_____</td></tr> </tbody> </table> <p>3) 25 m swim and boarding with suit and a lifejacket, if required</p> <table style="width:100%; border-collapse: collapse;"> <thead> <tr> <th style="width:60%;"></th> <th style="width:20%; text-align: center;">Passed</th> <th style="width:20%; text-align: center;">Failed</th> </tr> </thead> <tbody> <tr><td>Subject No.1</td><td style="text-align: center;">_____</td><td style="text-align: center;">_____</td></tr> <tr><td>Subject No.2</td><td style="text-align: center;">_____</td><td style="text-align: center;">_____</td></tr> <tr><td>Subject No.3</td><td style="text-align: center;">_____</td><td style="text-align: center;">_____</td></tr> <tr><td>Subject No.4</td><td style="text-align: center;">_____</td><td style="text-align: center;">_____</td></tr> <tr><td>Subject No.5</td><td style="text-align: center;">_____</td><td style="text-align: center;">_____</td></tr> <tr><td>Subject No.6</td><td style="text-align: center;">_____</td><td style="text-align: center;">_____</td></tr> </tbody> </table> <p>Comments/Observations</p>		Passed	Failed	Subject No.1	_____	_____	Subject No.2	_____	_____	Subject No.3	_____	_____	Subject No.4	_____	_____	Subject No.5	_____	_____	Subject No.6	_____	_____		Passed	Failed	Subject No.1	_____	_____	Subject No.2	_____	_____	Subject No.3	_____	_____	Subject No.4	_____	_____	Subject No.5	_____	_____	Subject No.6	_____	_____		Passed	Failed	Subject No.1	_____	_____	Subject No.2	_____	_____	Subject No.3	_____	_____	Subject No.4	_____	_____	Subject No.5	_____	_____	Subject No.6	_____	_____
	Passed	Failed																																																															
Subject No.1	_____	_____																																																															
Subject No.2	_____	_____																																																															
Subject No.3	_____	_____																																																															
Subject No.4	_____	_____																																																															
Subject No.5	_____	_____																																																															
Subject No.6	_____	_____																																																															
	Passed	Failed																																																															
Subject No.1	_____	_____																																																															
Subject No.2	_____	_____																																																															
Subject No.3	_____	_____																																																															
Subject No.4	_____	_____																																																															
Subject No.5	_____	_____																																																															
Subject No.6	_____	_____																																																															
	Passed	Failed																																																															
Subject No.1	_____	_____																																																															
Subject No.2	_____	_____																																																															
Subject No.3	_____	_____																																																															
Subject No.4	_____	_____																																																															
Subject No.5	_____	_____																																																															
Subject No.6	_____	_____																																																															

<b>Immersion suits (non-isolated)</b>	Manufacturer: _____ Model: _____ Lot/Serial Number: _____	Date: _____ Time: _____ Surveyor: _____ Organization: _____																		
<b>2.3.1.17 Oil resistance test</b>		<b>Regulations: LSA Code; MSC.81(70) 1/3.1.13</b>																		
Test Procedure	Acceptance Criteria	Significant Test Data																		
<p>After all its apertures have been sealed a non- insulated immersion suit should be immersed for a period of 24 h under 100 mm head of diesel oil at normal room temperature.</p> <p>The surface oil should then be wiped off and the immersion suit subjected to the test prescribed in 2.3.1.15.</p>	<p>The ingress of water should not exceed a mass of 200g.</p>	<p>Indicate which alternative is used.  <input type="checkbox"/>Alternative 1 <input type="checkbox"/>Alternative 2</p> <p>Water ingress ≤ 200g            Passed Failed</p> <table style="width:100%; border: none;"> <tr> <td style="width: 60%;">Subject No.1</td> <td style="width: 20%; text-align: center;">_____</td> <td style="width: 20%; text-align: center;">_____</td> </tr> <tr> <td>Subject No.2</td> <td style="text-align: center;">_____</td> <td style="text-align: center;">_____</td> </tr> <tr> <td>Subject No.3</td> <td style="text-align: center;">_____</td> <td style="text-align: center;">_____</td> </tr> <tr> <td>Subject No.4</td> <td style="text-align: center;">_____</td> <td style="text-align: center;">_____</td> </tr> <tr> <td>Subject No.5</td> <td style="text-align: center;">_____</td> <td style="text-align: center;">_____</td> </tr> <tr> <td>Subject No.6</td> <td style="text-align: center;">_____</td> <td style="text-align: center;">_____</td> </tr> </table> <p>Comments/Observations</p>	Subject No.1	_____	_____	Subject No.2	_____	_____	Subject No.3	_____	_____	Subject No.4	_____	_____	Subject No.5	_____	_____	Subject No.6	_____	_____
Subject No.1	_____	_____																		
Subject No.2	_____	_____																		
Subject No.3	_____	_____																		
Subject No.4	_____	_____																		
Subject No.5	_____	_____																		
Subject No.6	_____	_____																		

<b>Immersion suits (non-isolated)</b>	Manufacturer: _____ Model: _____ Lot/Serial Number: _____	Date: _____ Time: _____ Surveyor: _____ Organization: _____
<b>2.3.1.18 Alternative oil resistance test</b>		<b>Regulations: LSA Code; MSC.81(70) 1/3.1.14.1 &amp; .2</b>
Test Procedure	Acceptance Criteria	Significant Test Data
<p>In lieu of the test for oil resistance prescribed in 2.3.1.17 either of the following tests may be conducted.</p> <p>After all apertures have been sealed, the non-insulated immersion suit should be immersed for a period of 24 h under 100 mm head of diesel oil at normal room temperature if necessary using weights to keep suit submerged. Any surface oil should then be wiped off and the non-insulated immersion suit turned inside out. The suit should then be laid on a table suitable for collecting and draining off any leakage and be supported at the neck aperture by a suitable designed hanger. The suit should then be filled with water to neck level which should be 300mm above the table.</p> <p>Representative samples of the exterior fabric and seams should be immersed under 100mm head of diesel oil for 24 h. After removal from the oil the samples should be wiped off before being subjected to the following tests:</p> <p>.1 a hydrostatic test of a 1m water head; and</p> <p>.2 a tensile test of representative seams.</p>	<p>After 1h in this position there should be no leakage exceeding a mass of 200g</p> <p>The seam strength should be not less than 150 N</p> <p>The samples should successfully support 1 m head of water</p>	<p>Indicate which alternative is used.  <input type="checkbox"/> Alternative 1 <input type="checkbox"/> Alternative 2</p> <p>Water ingress ≤ 200g            Passed _____ Failed _____</p> <p>Subject No.1 _____            Subject No.2 _____            Subject No.3 _____            Subject No.4 _____            Subject No.5 _____            Subject No.6 _____</p> <p>Strength &gt; 150N Passed _____ Failed _____            Passed _____ Failed _____</p> <p>The samples should support a 1 m head of water.</p> <p>Comments/Observations</p>

<b>Immersion suits (non-isolated)</b>	Manufacturer: _____ Model: _____ Lot/Serial Number: _____	Date: _____ Time: _____ Surveyor: _____ Organization: _____
<b>2.3.1.19 Fire test</b>		<b>Regulations: LSA Code II/2.3.1.1.2; MSC.81(70) 1/3.1.15</b>
Test Procedure	Acceptance Criteria	Significant Test Data
<p>A test pan 30 cm x 35 cm x 6 cm should be placed in an essentially draught-free area. Water should be put in the bottom of the test pan to make a minimum total depth of 1 cm followed by enough petrol to make a minimum depth of 4 cm. The petrol should then be ignited and allowed to burn freely for 30 s. If necessary the immersion suit should be draped over a hanger to ensure the whole of the suit is enveloped in the flames, with the bottom of the suit 25 cm above the top edge of the test pan so that the duration of exposure to the flames is 2 s.</p>	<p>The non-insulated immersion suit should not sustain burning for more than 6 s or continue melting after being removed from exposure to the flames.</p>	<p>Did the immersion suit sustain burning for more than 6 s or continue melting after being removed from the flames?</p> <p><input type="checkbox"/> YES    <input type="checkbox"/> NO</p> <p>Comments/Observations</p>

<b>Immersion suits (non-isolated)</b>	Manufacturer: _____ Model: _____ Lot/Serial Number: _____	Date: _____ Time: _____ Surveyor: _____ Organization: _____
<b>2.3.1.20 Temperature cycling test</b>		<b>Regulations: LSA Code I/1.2.2.2; MSC.81(70) 1/3.1.16</b>
<b>Test Procedure</b>	<b>Acceptance Criteria</b>	<b>Significant Test Data</b>
<p>The following test should be carried out on two immersion suits</p> <p>The non-insulated immersion suits should be alternately subjected to surrounding temperatures of -30°C and +65°C. These alternating cycles need not follow immediately after each other and the following procedure, repeated for a total of 10 cycles, is acceptable:</p> <ol style="list-style-type: none"> <li>.1 an 8 h exposure at a minimum temperature of +65°C to be completed in one day; and</li> <li>.2 the specimens removed from the warm chamber that same day and left exposed under ordinary room conditions at a temperature of 20°C ± 3°C until the next day;</li> <li>.3 an 8 h exposure at a maximum temperature of -30°C to be completed the next day; and</li> <li>.4 the specimens removed from the cold chamber that same day and left exposed under ordinary room conditions at a temperature of 20°C ± 3°C until the next day.</li> </ol>	<p>The non-insulated immersion suits should show no signs of damage such as shrinking, swelling dissolution or changes of mechanical qualities.</p>	<p>(See following page for test data)</p> <p>Passed _____ Failed _____</p> <p>Comments/Observations</p>

<b>Immersion suits (non-isolated)</b>	Manufacturer: _____ Model: _____ Lot/Serial Number: _____	Date: _____ Time: _____ Surveyor: _____ Organization: _____
<b>2.3.1.21 Temperature cycling test - Test Data</b>		<b>Regulations: LSA Code I/1.2.1; MSC.81(70) 1/3.1.16</b>
	<b>HOT CYCLE</b>	<b>COLD CYCLE</b>
Cycle 1	Date In: _____ Time In: _____ Temperature: _____ °C Duration: _____ hours	Date In: _____ Time In: _____ Temperature: _____ °C Duration: _____ hours
Cycle 2	Date In: _____ Time In: _____ Temperature: _____ °C Duration: _____ hours	Date In: _____ Time In: _____ Temperature: _____ °C Duration: _____ hours
Cycle 3	Date In: _____ Time In: _____ Temperature: _____ °C Duration: _____ hours	Date In: _____ Time In: _____ Temperature: _____ °C Duration: _____ hours
Cycle 4	Date In: _____ Time In: _____ Temperature: _____ °C Duration: _____ hours	Date In: _____ Time In: _____ Temperature: _____ °C Duration: _____ hours
Cycle 5	Date In: _____ Time In: _____ Temperature: _____ °C Duration: _____ hours	Date In: _____ Time In: _____ Temperature: _____ °C Duration: _____ hours
Cycle 6	Date In: _____ Time In: _____ Temperature: _____ °C Duration: _____ hours	Date In: _____ Time In: _____ Temperature: _____ °C Duration: _____ hours
Cycle 7	Date In: _____ Time In: _____ Temperature: _____ °C Duration: _____ hours	Date In: _____ Time In: _____ Temperature: _____ °C Duration: _____ hours
Cycle 8	Date In: _____ Time In: _____ Temperature: _____ °C Duration: _____ hours	Date In: _____ Time In: _____ Temperature: _____ °C Duration: _____ hours
Cycle 9	Date In: _____ Time In: _____ Temperature: _____ °C Duration: _____ hours	Date In: _____ Time In: _____ Temperature: _____ °C Duration: _____ hours
Cycle 10	Date In: _____ Time In: _____ Temperature: _____ °C Duration: _____ hours	Date In: _____ Time In: _____ Temperature: _____ °C Duration: _____ hours

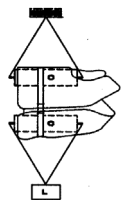
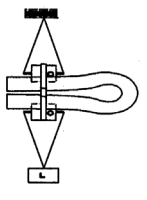
<b>Immersion suits (non-isolated)</b>	Manufacturer: _____ Model: _____ Lot/Serial Number: _____	Date: _____ Time: _____ Surveyor: _____ Organization: _____
<b>2.3.1.22 Buoyancy test</b>		<b>Regulations: LSA Code II/2.3.1.8; MSC.81(70) 1/3.1.17</b>
Test Procedure	Acceptance Criteria	Significant Test Data
<p>The buoyancy of a non-insulated immersion suit designed to be worn without a lifejacket should be measured before and after 24 h complete submersion to just below the surface in fresh water.</p> <p>The buoyancy shall not depend on the use of loose granulated materials</p>	<p>The difference between the initial buoyancy and the final buoyancy should not exceed 5% of the initial buoyancy</p>	<p>Buoyancy 1    Buoyancy 2    %difference          _____kg    _____kg</p> <p>_____ % Passed _____</p> <p style="text-align:center">Failed Comments/Observations</p>
<b>2.3.1.23 Strength test</b>		<b>Regulations: LSA Code II; MSC.81(70) 1/3.1.18</b>
Test Procedure	Acceptance Criteria	Significant Test Data
<p>The non-insulated immersion suit should be immersed in water for a period of 2 min. It should then be removed from the water and closed in the same manner as when worn by a person A force of not less than 3200 N should be applied to the lifting loop and a force of not less than 1350 N should be applied to the parts other than the lifting loop for 30 min.</p> <p>The non-inflated immersion suit may be cut if necessary to accommodate to the test device.</p>	<p>The non-insulated immersion suit should not be damaged as a result of this test.</p> <div style="text-align:center; margin-top: 20px;">   </div> <p style="text-align:center; margin-top: 10px;">Vest-type lifejacket      Yoke or over-the-head type lifejacket</p>	<p>Passed _____      Failed _____</p> <p style="text-align:center; margin-top: 20px;">Comments/Observations</p>



<b>Immersion suits (non-isolated)</b>	Manufacturer: _____ Model: _____ Lot/Serial Number: _____	Date: _____ Time: _____ Surveyor: _____ Organization: _____
<b>2.3.1.24 Thermal protective test (General)</b>		<b>Regulations: LSA Code II/2.3.2.1; MSC.81(70) 1/3.2.1 – 3.2.4</b>
Test Procedure	Acceptance Criteria	Significant Test Data
<p>The thermal protective qualities may be measured using a thermal manikin, when such a method is required by an Administration and has been demonstrated to provide test results which correlate satisfactorily in all aspects to test results using human subjects.</p> <p>If human subjects are used, they should be medically examined before being accepted for the tests. Each design of immersion suit is to be tested by test subjects specified in 2.3.1.5</p> <p>Where human subjects are used, the tests should always be conducted under the supervision of physician. Emergency resuscitation equipment should be available during all tests. For safety reasons, ECG should be monitored during every test. Testing should be stopped at the wish of the test subjects, or if the skin temperature of hand, foot or lumbar region should fall below 10° C, or if the attending physician considers it advisable.</p> <p>When testing with human subjects, continuous body core temperature (rectal temperature) and skin temperature of lumbar region, both hands, calves, foot (foot instep) and heels, should be measured. The accuracy of the measuring system should be ±0.2°C. Appropriate corresponding measurements should be taken if a manikin is used in lieu of human subjects.</p>		Comments/Observations

<b>Immersion suits (non-isolated)</b>	Manufacturer: _____ Model: _____ Lot/Serial Number: _____	Date: _____ Time: _____ Surveyor: _____ Organization: _____																																							
<b>2.3.1.25 Thermal Protective test (Continued)</b>		<b>Regulations: LSA Code II/2.3.2.1.2; MSC.81(70) 1/3.2.9 &amp; 3.2.10</b>																																							
Test Procedure	Acceptance Criteria	Significant Test Data																																							
<p>Prior to tests, the same amount of water resulting from the water ingress and jump test in 2.3.1.13 should be poured into the dry suit worn over the dry test clothing specified in 2.3.1.7 by the test subject lying down.</p> <p>Each test subject should wear a non-insulated immersion suit previously subjected to the jump test in 2.3.1.14. Following a 1 h period of immersion, with hands gloved, in circulating calm water at + 5° C, each test subject's body core temperature should not fall more than 2° C below the normal level of the subject's temperature.</p> <p>The non-insulated immersion suit should provide sufficient thermal protection to ensure that immediately on leaving the water after completion of the test prescribed above each test subject can pick up a pencil as specified in 2.3.1.9 and write.</p>	<p>Following immersion each test subject's body core temperature should not fall more than 2°C below the normal level of the subject's temperature.</p>	<p>Same amount of water resulting from the water ingress and jump test in paragraph 2.3.1.13 should be poured into the dry suit.</p> <table border="0" style="width: 100%;"> <tr> <td style="text-align: center;">Beginning of test</td> <td style="text-align: center;">End of test</td> <td style="text-align: center;">normal temperature</td> </tr> <tr> <td>Subject No.1</td> <td></td> <td></td> </tr> <tr> <td>Subject No.2</td> <td></td> <td></td> </tr> <tr> <td>Subject No.3</td> <td></td> <td></td> </tr> <tr> <td>Subject No.4</td> <td></td> <td></td> </tr> <tr> <td>Subject No.5</td> <td></td> <td></td> </tr> <tr> <td>Subject No.6</td> <td></td> <td></td> </tr> </table> <p>Passed _____ Failed _____</p> <p>Pick up a pencil and write after 1 h period of immersion:</p> <table border="0" style="width: 100%;"> <tr> <td>Subject No 1</td> <td><input type="checkbox"/>YES</td> <td><input type="checkbox"/>NO</td> </tr> <tr> <td>Subject No 2</td> <td><input type="checkbox"/>YES</td> <td><input type="checkbox"/>NO</td> </tr> <tr> <td>Subject No 3</td> <td><input type="checkbox"/>YES</td> <td><input type="checkbox"/>NO</td> </tr> <tr> <td>Subject No 4</td> <td><input type="checkbox"/>YES</td> <td><input type="checkbox"/>NO</td> </tr> <tr> <td>Subject No 5</td> <td><input type="checkbox"/>YES</td> <td><input type="checkbox"/>NO</td> </tr> <tr> <td>Subject No 6</td> <td><input type="checkbox"/>YES</td> <td><input type="checkbox"/>NO</td> </tr> </table> <p>Passed _____ Failed _____</p> <p>Comments/Observations</p> <p>See attached test sheets for temperatures during the immersion tests.</p>	Beginning of test	End of test	normal temperature	Subject No.1			Subject No.2			Subject No.3			Subject No.4			Subject No.5			Subject No.6			Subject No 1	<input type="checkbox"/> YES	<input type="checkbox"/> NO	Subject No 2	<input type="checkbox"/> YES	<input type="checkbox"/> NO	Subject No 3	<input type="checkbox"/> YES	<input type="checkbox"/> NO	Subject No 4	<input type="checkbox"/> YES	<input type="checkbox"/> NO	Subject No 5	<input type="checkbox"/> YES	<input type="checkbox"/> NO	Subject No 6	<input type="checkbox"/> YES	<input type="checkbox"/> NO
Beginning of test	End of test	normal temperature																																							
Subject No.1																																									
Subject No.2																																									
Subject No.3																																									
Subject No.4																																									
Subject No.5																																									
Subject No.6																																									
Subject No 1	<input type="checkbox"/> YES	<input type="checkbox"/> NO																																							
Subject No 2	<input type="checkbox"/> YES	<input type="checkbox"/> NO																																							
Subject No 3	<input type="checkbox"/> YES	<input type="checkbox"/> NO																																							
Subject No 4	<input type="checkbox"/> YES	<input type="checkbox"/> NO																																							
Subject No 5	<input type="checkbox"/> YES	<input type="checkbox"/> NO																																							
Subject No 6	<input type="checkbox"/> YES	<input type="checkbox"/> NO																																							

<b>Immersion suits (non-isolated)</b>		Manufacturer: _____ Model: _____ Lot/Serial Number: _____	Date: _____ Time: _____ Surveyor: _____ Organization: _____		
<b>2.1.3.26 Test sheets for temperatures during immersion tests</b>			<b>Regulations: LSA Code II/2.3.2.1.2; MSC.81(70) 1/3.2.9 &amp; 3.2.10</b>		
<b>SUBJECT 1</b>	<b>SUBJECT 2</b>	<b>SUBJECT 3</b>	<b>SUBJECT 4</b>	<b>SUBJECT 5</b>	<b>SUBJECT 6</b>
Rectal temp after 1 hr: _____	Rectal temp after 1 hr: _____	Rectal temp after 1 hr: _____	Rectal temp after 1 hr: _____	Rectal temp after 1 hr: _____	Rectal temp after 1 hr: _____
Skin temp at lumbar region after 1 hr: _____	Skin temp at lumbar region after 1 hr: _____	Skin temp at lumbar region after 1 hr: _____	Skin temp at lumbar region after 1 hr: _____	Skin temp at lumbar region after 1 hr: _____	Skin temp at lumbar region after 1 hr: _____
Skin temp at left hand after 1 hr: _____	Skin temp at left hand after 1 hr: _____	Skin temp at left hand after 1 hr: _____	Skin temp at left hand after 1 hr: _____	Skin temp at left hand after 1 hr: _____	Skin temp at left hand after 1 hr: _____
Skin temp at right hand after 1 hr: _____	Skin temp at right hand after 1 hr: _____	Skin temp at right hand after 1 hr: _____	Skin temp at right hand after 1 hr: _____	Skin temp at right hand after 1 hr: _____	Skin temp at right hand after 1 hr: _____
Skin temp at calves after 1 hr: _____	Skin temp at calves after 1 hr: _____	Skin temp at calves after 1 hr: _____	Skin temp at calves after 1 hr: _____	Skin temp at calves after 1 hr: _____	Skin temp at calves after 1 hr: _____
Skin temp at left foot (foot instep) after 1 hr: _____	Skin temp at left foot (foot instep) after 1 hr: _____	Skin temp at left foot (foot instep) after 1 hr: _____	Skin temp at left foot (foot instep) after 1 hr: _____	Skin temp at left foot (foot instep) after 1 hr: _____	Skin temp at left foot (foot instep) after 1 hr: _____
Skin temp at right foot (foot instep) after 1 hr: _____	Skin temp at right foot (foot instep) after 1 hr: _____	Skin temp at right foot (foot instep) after 1 hr: _____	Skin temp at right foot (foot instep) after 1 hr: _____	Skin temp at right foot (foot instep) after 1 hr: _____	Skin temp at right foot (foot instep) after 1 hr: _____
Skin temp at left heel after 1 hr: _____	Skin temp at left heel after 1 hr: _____	Skin temp at left heel after 1 hr: _____	Skin temp at left heel after 1 hr: _____	Skin temp at left heel after 1 hr: _____	Skin temp at left heel after 1 hr: _____

## **2.3.2 IMMERSION SUITS (INSULATED)**

### **EVALUATION AND TEST REPORT**

- 2.3.2.1 General data and specifications
- 2.3.2.2 Submitted drawings, reports and documents
- 2.3.2.3 Quality assurance
- 2.3.2.4 Visual inspection
- 2.3.2.5 Test subjects
- 2.3.2.6 Test with a lifejacket
- 2.3.2.7 Test clothing
- 2.3.2.8 Donning tests 1 & 2
- 2.3.2.9 Ergonomic test
- 2.3.2.10 Field of vision test
- 2.3.2.11 Flotation test
- 2.3.2.12 Righting test
- 2.3.2.13 Water ingress and jump test
- 2.3.2.14 Jump test
- 2.3.2.15 Leak test
- 2.3.2.16 Swimming and water emergence test
- 2.3.2.17 Oil resistance test
- 2.3.2.18 Alternative oil resistance test
- 2.3.2.19 Fire test
- 2.3.2.20 Temperature cycling test
- 2.3.2.21 Temperature cycling test - Test data
- 2.3.2.22 Buoyancy test
- 2.3.2.23 Strength test
- 2.3.2.24 Thermal protective test (General)
- 2.3.2.25 Thermal protective test (Continued)
- 2.3.2.26 Test sheets for temperatures during immersion tests

**2.3.2 IMMERSION SUITS (INSULATED)**  
**EVALUATION AND TEST REPORT**

<b>Manufacturer</b>	
<b>Type</b>	
<b>Date</b>	
<b>Place</b>	
<b>Name Surveyor printed</b>	
<b>Signature</b>	
<b>Approving Organization</b>	

<b>Immersion suits (insulated)</b>	Manufacturer: _____ Model: _____ Lot/Serial Number: _____	Date: _____ Time: _____ Surveyor: _____ Organization: _____
<b>2.3.2.1 General data and specifications</b>		<b>Regulations: LSA Code 2.3; MSC.81(70) 1/3.1 &amp; 3.2</b>
<b>Construction Material:</b>  Fabric produced by: _____  Type: _____  Buoyant material produced by: _____  Type: _____	<b>Additional equipment:</b>  Retro reflective material produced by: _____ Type: _____  Whistle produced by (if fitted): _____ Type: _____  Life-line produced by (if fitted): _____ Type _____  Light produced by (if fitted): _____ Type: _____	<b>Donning instructions:</b>  <input type="checkbox"/> YES <input type="checkbox"/> NO

<b>Immersion suits (insulated)</b>		Manufacturer: _____ Model: _____ Lot/Serial Number: _____	Date: _____ Time: _____ Surveyor: _____ Organization: _____
<b>2.3.2.2 Submitted drawings, reports and documents</b>			
<b>Submitted drawings and documents</b>			<b>Status</b>
<b>Drawing No.</b>	<b>Revision No. &amp; date</b>	<b>Title of drawing</b>	
<b>Submitted reports and documents</b>			<b>Status</b>
<b>Report/Document No.</b>	<b>Revision No. &amp; date</b>	<b>Title of report / document</b>	
		Maintenance Manual -	
		Operations Manual -	

<b>Immersion suits (insulated)</b>	Manufacturer: _____ Model: _____ Lot/Serial Number: _____	Date: _____ Time: _____ Surveyor: _____ Organization: _____
<b>2.3.2.3 Quality assurance</b>		<b>Regulations: MSC.81(70) 2/1.1, 1.2</b>
<p>Except where all appliances of a particular type are required by Chapter III of the International Convention for the Safety of Life at Sea, 1974, as amended, or the international Life-Saving Appliance (LSA) Code, to be inspected, representatives of the Administration should make random inspections of manufacturers to ensure that the quality of life-saving appliances and materials used comply with the specification of the approved prototype life-saving appliance.</p> <p>Manufacturers should be required to institute a quality control procedure to ensure that life-saving appliances are produced to the same standard as the prototype life-saving appliance approved by the Administration and to keep records of any production tests carried out in accordance with the Administration's instructions.</p>		<p>Quality Assurance Standard Used: -</p> <p>Quality Assurance Procedure: -</p> <p>Quality Assurance Manual: -</p> <p>Description of System.</p> <p>Quality Assurance System acceptable Yes/No</p> <p>Comments/Observations</p>



<b>Immersion suits (insulated)</b>	Manufacturer: _____ Model: _____ Lot/Serial Number: _____	Date: _____ Time: _____ Surveyor: _____ Organization: _____
<b>2.3.2.4 Visual inspection</b>		<b>Regulations: LSA Code I/1.2.2, &amp; II/2.3.1.1.3 &amp; 2.3.1.1.4</b>
<p>Insulated Immersion suit should:</p> <p>.1 be clearly marked with approval information including the Administration which approved it, date of manufacturer and any operational restrictions;</p> <p>.2 be provided with labels giving operating instructions, general information and manufacturers details as appropriate; and</p> <p>.3 be fitted with approved patches of retro-reflective material with a total area of at least 400 cm<sup>2</sup> and with 100 cm<sup>2</sup> on the back if the suit does not automatically turn the wearer face up according to resolution A.658(16).</p>		<p>Passed _____ Failed _____</p> <p>Passed _____ Failed _____</p> <p>Passed _____ Failed _____</p> <p>Comments/Observations</p>

<b>Immersion suits (insulated)</b>	Manufacturer: _____ Model: _____ Lot/Serial Number: _____	Date: _____ Time: _____ Surveyor: _____ Organization: _____
<b>2.3.2.4 Visual Inspection (continued)</b>		<b>Regulations: LSA Code I/1.2.2, &amp; II/2.3.1.1.3 &amp; 2.3.1.1.4, 2.3.1.4-6</b>
Test Procedure	Acceptance Criteria	Significant Test Data
Does the immersion suit cover the whole body with the exception of the face?	Be of an international or vivid reddish orange, or a comparably highly visible colour on all parts where this will assist detection at sea.	Passed _____ Failed _____
Are the hands covered, or is the immersion suit equipped with permanently attached gloves?		Passed _____ Failed _____
Are their arrangements to prevent excessive free air in the legs?		Passed _____ Failed _____
Is the immersion suit of highly visible colour?		Passed _____ Failed _____
Is the immersion suit designed to be worn without a lifejacket?		Passed _____ Failed _____
If yes,		Passed _____ Failed _____
Is the immersion suit fitted with a light complying with paragraph 2.2.3?		Passed _____ Failed _____
Is the immersion suit fitted with a whistle complying with paragraph 2.2.1.14 of LSA Code?		Passed _____ Failed _____
Fitted with releasable buoyant lifeline or other means to secure it to a suit worn by another person in the water & provided with a suitable means to allow rescuer to lift the wearer from the water into survival or rescue craft.		Comments/Observations

<b>Immersion suits (insulated)</b>	Manufacturer: _____ Model: _____ Lot/Serial Number: _____	Date: _____ Time: _____ Surveyor: _____ Organization: _____	
<b>2.3.2.5 Test subjects</b>		<b>Regulations: LSA Code I/; MSC.81(70) 1/3.1.1</b>	
Test Procedure	Acceptance Criteria	Significant Test Data	
At least six able-bodied persons both male and females of the following heights and weights should be used. At least one and not more than two of the persons should be females with not more than one female in the same height range.	<u>Height</u>	<u>Weight</u>	
	1.4 m - 1.6 m;	1 person under 60kg 1 person over 60kg	Male/Female Height      Weight Subject No.1 _____ Subject No.2 _____ Subject No.3 _____ Subject No.4 _____ Subject No.5 _____ Subject No.6 _____
	1.6 m - 1.8 m	1 person under 70kg 1 person over 70kg	
	over 1.8 m	1 person under 80kg 1 person over 80kg	Comments/Observations
<b>2.3.2.6 Test with a lifejacket</b>		<b>Regulations: LSA Code 2.3.1.7; MSC.81(70) 1/3.1.2</b>	
Test Procedure	Acceptance Criteria	Significant Test Data	
If the suit is to be worn in conjunction with a lifejacket, the lifejacket should be worn over the suit for the tests prescribed in 2.3.2.8 to 2.3.2.16.		Manufacturer of lifejacket: _____	
		Type: _____	
		Manufacturer of lifejacket: _____	
		Type: _____	
		Manufacturer of lifejacket: _____	
		Type: _____	

<b>Immersion suits (insulated)</b>	Manufacturer: _____ Model: _____ Lot/Serial Number: _____	Date: _____ Time: _____ Surveyor: _____ Organization: _____																												
<b>2.3.2.7 Test clothing</b>		<b>Regulations: LSA Code II/2.3.1.1.1; MSC.81(70) 1/3.2.6, 3.2.7</b>																												
Test Procedure	Acceptance Criteria	Significant Test Data																												
<p>The test subjects should wear a standard range clothing consisting of</p> <p>.1 underwear (short sleeved, short legged)</p> <p>.2 shirt(long sleeved)</p> <p>.3 trousers(not woollen, and</p> <p>.4 woollen socks</p> <p>.5 If suit is to be worn in conjunction with a lifejacket, the lifejacket should be worn during the thermal protective tests.</p>		<p>Did all test subject use the specified test clothing?</p> <p>YES NO</p> <p>Comments/Observations</p>																												
<b>2.3.2.8 Donning test (1)</b>		<b>Regulations: LSA Code II/2.3.1.1.1; MSC.81(70) 1/3.1.3</b>																												
Test Procedure	Acceptance Criteria	Significant Test Data																												
<p>Following a demonstration, each test subject should be able to unpack, don and secure the suit over their test clothing without assistance in less than 2 min. This time should include the time to don any associated clothing, inflate any orally inflated chambers if fitted, and don a lifejacket, if such is to be worn in conjunction with the suit, and the test subjects should be able to don such lifejacket without assistance.</p>	<p>Each test subjects should be able to unpack, don and secure the immersion suit over their test clothing (see 2.3.2.7) without assistance in less than 2 min. This time should include the time to don any associated clothing, and a lifejacket, if such is to be worn in conjunction with the immersion suit.</p>	<p><u>Donning time normal clothing</u></p> <table border="0"> <tr> <td></td> <td>Time</td> <td>Pass</td> <td>Fail</td> </tr> <tr> <td>Subject No.1</td> <td>_____ sec</td> <td></td> <td></td> </tr> <tr> <td>Subject No.2</td> <td>_____ sec</td> <td></td> <td></td> </tr> <tr> <td>Subject No.3</td> <td>_____ sec</td> <td></td> <td></td> </tr> <tr> <td>Subject No.4</td> <td>_____ sec</td> <td></td> <td></td> </tr> <tr> <td>Subject No.5</td> <td>_____ sec</td> <td></td> <td></td> </tr> <tr> <td>Subject No.6</td> <td>_____ sec</td> <td></td> <td></td> </tr> </table> <p>Comments/Observations</p>		Time	Pass	Fail	Subject No.1	_____ sec			Subject No.2	_____ sec			Subject No.3	_____ sec			Subject No.4	_____ sec			Subject No.5	_____ sec			Subject No.6	_____ sec		
	Time	Pass	Fail																											
Subject No.1	_____ sec																													
Subject No.2	_____ sec																													
Subject No.3	_____ sec																													
Subject No.4	_____ sec																													
Subject No.5	_____ sec																													
Subject No.6	_____ sec																													

<b>Immersion suits (insulated)</b>	Manufacturer: _____ Model: _____ Lot/Serial Number: _____	Date: _____ Time: _____ Surveyor: _____ Organization: _____
<b>2.3.2.8 Donning test (2)</b>		<b>Regulations: LSA Code II/2.3.1.1.1; MSC.81(70) 1/3.1.4</b>
Test Procedure	Acceptance Criteria	Significant Test Data
The immersion suit should be capable of being donned in 5 min at an ambient temperature as low as -30° C. Before the donning test the packed immersion suit should be kept in a refrigerated chamber at a temperature of -30° C for 24 h.	The test subject should be able to complete this task in 5 min.	Donning time at - 30°C Time                      Pass                      Fail Subject No.1 _____ sec Subject No.2 _____ sec Subject No.3 _____ sec Subject No.4 _____ sec Subject No.5 _____ sec Subject No.6 _____ sec Comments/Observations
<b>2.3.2.9 Ergonomic Test</b>		<b>Regulations: LSA Code II/2.3.1.3.2; MSC.81(70) 1/3.1.5</b>
Test Procedure	Acceptance Criteria	Significant Test Data
When wearing the immersion suit, the test subjects should be able to:  .1 Climb up and down a vertical ladder of at least 5 m in length;  .2 Perform all duties associated with abandonment; and  .3 To pick up a pencil and write. The diameter of the pencil should be 8-10 mm.	There should be no restriction in walking, bending over or arm movement.	Restriction in walking, bending over or arm movement: <input type="checkbox"/> YES <input type="checkbox"/> NO All the test subjects were able to pick up a pencil and write: <input type="checkbox"/> YES <input type="checkbox"/> NO All the test subjects were able to put on the lifejacket without assistance: <input type="checkbox"/> YES <input type="checkbox"/> NO All the test subjects were able to perform all duties associated with abandonment, assist others and operate a rescue boat: <input type="checkbox"/> YES <input type="checkbox"/> NO All the test subjects were able to climb up and down a vertical ladder of 5 meter in length: <input type="checkbox"/> YES <input type="checkbox"/> NO Comments/Observations

<b>Immersion suits (insulated)</b>	Manufacturer: _____ Model: _____ Lot/Serial Number: _____	Date: _____ Time: _____ Surveyor: _____ Organization: _____																					
<b>2.3.2.10 Field of vision test</b>		<b>Regulations: LSA Code II/2.3.1.1.3; MSC.81(70) 1/3.1.6</b>																					
Test Procedure	Acceptance Criteria	Significant Test Data																					
Each test subject should be seated with the head in a fixed position, and the lateral field of vision measured.	The lateral field of vision should be at least 120°.	Field of vision angle $\square$ 120°  <table style="width:100%; border:none;"> <tr> <td></td> <td style="text-align:center">Passed</td> <td style="text-align:center">Failed</td> </tr> <tr> <td>Subject No.1</td> <td style="text-align:center">_____</td> <td style="text-align:center">_____</td> </tr> <tr> <td>Subject No.2</td> <td style="text-align:center">_____</td> <td style="text-align:center">_____</td> </tr> <tr> <td>Subject No.3</td> <td style="text-align:center">_____</td> <td style="text-align:center">_____</td> </tr> <tr> <td>Subject No.4</td> <td style="text-align:center">_____</td> <td style="text-align:center">_____</td> </tr> <tr> <td>Subject No.5</td> <td style="text-align:center">_____</td> <td style="text-align:center">_____</td> </tr> <tr> <td>Subject No.6</td> <td style="text-align:center">_____</td> <td style="text-align:center">_____</td> </tr> </table> Comments/Observations		Passed	Failed	Subject No.1	_____	_____	Subject No.2	_____	_____	Subject No.3	_____	_____	Subject No.4	_____	_____	Subject No.5	_____	_____	Subject No.6	_____	_____
	Passed	Failed																					
Subject No.1	_____	_____																					
Subject No.2	_____	_____																					
Subject No.3	_____	_____																					
Subject No.4	_____	_____																					
Subject No.5	_____	_____																					
Subject No.6	_____	_____																					
<b>2.3.2.11 Flotation test</b>		<b>Regulations: LSA Code II/2. 3.1.1; MSC.81(70) 1/3.1.7</b>																					
Test Procedure	Acceptance Criteria	Significant Test Data																					
With the test subject floating at rest, wearing the suit in conjunction with a lifejacket if required, the freeboard should be measured from the water surface to the nose or mouth.	The test subject should float face-up with their mouths clear of the water by at least 120mm and be stable in that position.  For a buoyant insulated immersion suit worn without a lifejacket, an auxiliary means of buoyancy such as an orally inflated bladder behind the wearer's head may be used to obtain this freeboard, provided that the freeboard obtained without the auxiliary means of buoyancy is at least 50 mm.  The position of the lifejacket light should permit it to be visible over as great a segment of the upper hemisphere as is practicable.	<table style="width:100%; border:none;"> <tr> <td></td> <td style="text-align:center">Mouth Freeboard = ↓</td> <td style="text-align:center">Nose Freeboard = ↓</td> </tr> <tr> <td>Subject No.1</td> <td style="text-align:center">_____</td> <td style="text-align:center">_____</td> </tr> <tr> <td>Subject No.2</td> <td style="text-align:center">_____</td> <td style="text-align:center">_____</td> </tr> <tr> <td>Subject No.3</td> <td style="text-align:center">_____</td> <td style="text-align:center">_____</td> </tr> <tr> <td>Subject No.4</td> <td style="text-align:center">_____</td> <td style="text-align:center">_____</td> </tr> <tr> <td>Subject No.5</td> <td style="text-align:center">_____</td> <td style="text-align:center">_____</td> </tr> <tr> <td>Subject No.6</td> <td style="text-align:center">_____</td> <td style="text-align:center">_____</td> </tr> </table> Comments/Observations		Mouth Freeboard = ↓	Nose Freeboard = ↓	Subject No.1	_____	_____	Subject No.2	_____	_____	Subject No.3	_____	_____	Subject No.4	_____	_____	Subject No.5	_____	_____	Subject No.6	_____	_____
	Mouth Freeboard = ↓	Nose Freeboard = ↓																					
Subject No.1	_____	_____																					
Subject No.2	_____	_____																					
Subject No.3	_____	_____																					
Subject No.4	_____	_____																					
Subject No.5	_____	_____																					
Subject No.6	_____	_____																					

<b>Immersion suits (insulated)</b>	Manufacturer: _____ Model: _____ Lot/Serial Number: _____	Date: _____ Time: _____ Surveyor: _____ Organization: _____																					
<b>2.3.2.12 Righting test</b>		<b>Regulations: LSA Code II/2.3.1.2; MSC.81(70) 1/3.1.8</b>																					
Test Procedure	Acceptance Criteria	Significant Test Data																					
The test subjects, in fresh water wearing either an immersion suit or an immersion suit with lifejacket, should each demonstrate that they can turn themselves from a face-down to a face-up position in not more than 5 s.	Except where it has been demonstrated that the insulated immersion suit will right the test subjects within 5 s, the test subjects should each demonstrate that they can turn themselves from a face-down to a face-up position in not more than 5 s.	Righting time = $\leq 5$ s <table style="width:100%; border:none;"> <tr> <td></td> <td style="text-align:center;">Passed</td> <td style="text-align:center;">Failed</td> </tr> <tr> <td>Subject No.1</td> <td style="text-align:center;">_____</td> <td style="text-align:center;">_____</td> </tr> <tr> <td>Subject No.2</td> <td style="text-align:center;">_____</td> <td style="text-align:center;">_____</td> </tr> <tr> <td>Subject No.3</td> <td style="text-align:center;">_____</td> <td style="text-align:center;">_____</td> </tr> <tr> <td>Subject No.4</td> <td style="text-align:center;">_____</td> <td style="text-align:center;">_____</td> </tr> <tr> <td>Subject No.5</td> <td style="text-align:center;">_____</td> <td style="text-align:center;">_____</td> </tr> <tr> <td>Subject No.6</td> <td style="text-align:center;">_____</td> <td style="text-align:center;">_____</td> </tr> </table> Comments/Observations		Passed	Failed	Subject No.1	_____	_____	Subject No.2	_____	_____	Subject No.3	_____	_____	Subject No.4	_____	_____	Subject No.5	_____	_____	Subject No.6	_____	_____
	Passed	Failed																					
Subject No.1	_____	_____																					
Subject No.2	_____	_____																					
Subject No.3	_____	_____																					
Subject No.4	_____	_____																					
Subject No.5	_____	_____																					
Subject No.6	_____	_____																					
<b>2.3.2.13 Water ingress and jump test</b>		<b>Regulations: MSC.81(70) 1/3.1.9</b>																					
Test Procedure	Acceptance Criteria	Significant Test Data																					
The test subjects should pre-wet their immersion suit and then be weighed. Following a jump into the water from a height sufficient to totally immerse the body, each test subject should be weighed again.  Weighing should be performed on a machine accurate to $\pm 100$ g.	The difference in the combined mass of the test subject and the suit should not exceed 500 g.	Mass difference $\leq 500$ g <table style="width:100%; border:none;"> <tr> <td></td> <td style="text-align:center;">Passed</td> <td style="text-align:center;">Failed</td> </tr> <tr> <td>Subject No.1</td> <td style="text-align:center;">_____</td> <td style="text-align:center;">_____</td> </tr> <tr> <td>Subject No.2</td> <td style="text-align:center;">_____</td> <td style="text-align:center;">_____</td> </tr> <tr> <td>Subject No.3</td> <td style="text-align:center;">_____</td> <td style="text-align:center;">_____</td> </tr> <tr> <td>Subject No.4</td> <td style="text-align:center;">_____</td> <td style="text-align:center;">_____</td> </tr> <tr> <td>Subject No.5</td> <td style="text-align:center;">_____</td> <td style="text-align:center;">_____</td> </tr> <tr> <td>Subject No.6</td> <td style="text-align:center;">_____</td> <td style="text-align:center;">_____</td> </tr> </table> Comments/Observations		Passed	Failed	Subject No.1	_____	_____	Subject No.2	_____	_____	Subject No.3	_____	_____	Subject No.4	_____	_____	Subject No.5	_____	_____	Subject No.6	_____	_____
	Passed	Failed																					
Subject No.1	_____	_____																					
Subject No.2	_____	_____																					
Subject No.3	_____	_____																					
Subject No.4	_____	_____																					
Subject No.5	_____	_____																					
Subject No.6	_____	_____																					

<b>Immersion suits (insulated)</b>	Manufacturer: _____ Model: _____ Lot/Serial Number: _____	Date: _____ Time: _____ Surveyor: _____ Organization: _____																								
<b>2.3.2.14 Jump test</b>																										
<b>Regulations: LSA Code II/2.3.1.3.3; MSC.81(70) 1/3.1.10</b>																										
<p style="text-align: center;">Test Procedure</p> <p>The test subjects should jump with the suit and lifejacket if required from a height of 4.5m vertically into the water. After the jump, the immersion suit and its attachments should be examined for damage or dislodging, and the test subject should be questioned concerning whether the suit caused any injury to the wearer.</p>	<p style="text-align: center;">Acceptance Criteria</p> <p>The immersion suit and its attachments should not be damaged or dislodged in any way.</p> <p>The test subject should not be injured by the suit.</p>	<p style="text-align: center;">Significant Test Data</p> <table border="1" style="width: 100%; border-collapse: collapse;"> <thead> <tr> <th style="width: 60%;"></th> <th style="width: 20%; text-align: center;">Passed</th> <th style="width: 20%; text-align: center;">Failed</th> </tr> </thead> <tbody> <tr> <td>Subject No.1</td> <td style="text-align: center;">_____</td> <td style="text-align: center;">_____</td> </tr> <tr> <td>Subject No.2</td> <td style="text-align: center;">_____</td> <td style="text-align: center;">_____</td> </tr> <tr> <td>Subject No.3</td> <td style="text-align: center;">_____</td> <td style="text-align: center;">_____</td> </tr> <tr> <td>Subject No.4</td> <td style="text-align: center;">_____</td> <td style="text-align: center;">_____</td> </tr> <tr> <td>Subject No.5</td> <td style="text-align: center;">_____</td> <td style="text-align: center;">_____</td> </tr> <tr> <td>Subject No.6</td> <td style="text-align: center;">_____</td> <td style="text-align: center;">_____</td> </tr> <tr> <td>Comments/Observations</td> <td colspan="2"></td> </tr> </tbody> </table>		Passed	Failed	Subject No.1	_____	_____	Subject No.2	_____	_____	Subject No.3	_____	_____	Subject No.4	_____	_____	Subject No.5	_____	_____	Subject No.6	_____	_____	Comments/Observations		
	Passed	Failed																								
Subject No.1	_____	_____																								
Subject No.2	_____	_____																								
Subject No.3	_____	_____																								
Subject No.4	_____	_____																								
Subject No.5	_____	_____																								
Subject No.6	_____	_____																								
Comments/Observations																										
<b>2.3.2.15 Leak test</b>																										
<b>Regulations: LSA Code II/2.3.1.1.1; MSC.81(70) 1/3.1.11</b>																										
<p style="text-align: center;">Test Procedure</p> <p>The test subject should pre-wet the immersion suit and be weighed. The test subject should then be instructed to do one of the following:</p> <p>.1 a period of flotation in calm water of 1h; or</p> <p>.2 swimming for 20 min for a distance of at least 200 m</p> <p>The test subject should be weighed again after the task.</p> <p>The weighing machine should be accurate to <math>\pm</math> 100g.</p>	<p style="text-align: center;">Acceptance Criteria</p> <p>The ingress of water into the pre-wetted suit should not exceed a mass of 200g.</p>	<p style="text-align: center;">Significant Test Data</p> <p>Indicate which alternative is used.  <input type="checkbox"/> Alternative 1 <input type="checkbox"/> Alternative 2</p> <p>Water ingress <math>\leq</math> 200g</p> <table border="1" style="width: 100%; border-collapse: collapse;"> <thead> <tr> <th style="width: 60%;"></th> <th style="width: 20%; text-align: center;">Passed</th> <th style="width: 20%; text-align: center;">Failed</th> </tr> </thead> <tbody> <tr> <td>Subject No.1</td> <td style="text-align: center;">_____</td> <td style="text-align: center;">_____</td> </tr> <tr> <td>Subject No.2</td> <td style="text-align: center;">_____</td> <td style="text-align: center;">_____</td> </tr> <tr> <td>Subject No.3</td> <td style="text-align: center;">_____</td> <td style="text-align: center;">_____</td> </tr> <tr> <td>Subject No.4</td> <td style="text-align: center;">_____</td> <td style="text-align: center;">_____</td> </tr> <tr> <td>Subject No.5</td> <td style="text-align: center;">_____</td> <td style="text-align: center;">_____</td> </tr> <tr> <td>Subject No.6</td> <td style="text-align: center;">_____</td> <td style="text-align: center;">_____</td> </tr> <tr> <td>Comments/Observations</td> <td colspan="2"></td> </tr> </tbody> </table>		Passed	Failed	Subject No.1	_____	_____	Subject No.2	_____	_____	Subject No.3	_____	_____	Subject No.4	_____	_____	Subject No.5	_____	_____	Subject No.6	_____	_____	Comments/Observations		
	Passed	Failed																								
Subject No.1	_____	_____																								
Subject No.2	_____	_____																								
Subject No.3	_____	_____																								
Subject No.4	_____	_____																								
Subject No.5	_____	_____																								
Subject No.6	_____	_____																								
Comments/Observations																										



<b>Immersion suits (insulated)</b>	Manufacturer: _____ Model: _____ Lot/Serial Number: _____	Date: _____ Time: _____ Surveyor: _____ Organization: _____																																										
<b>2.3.2.16 Swimming and water emergence test</b>		<b>Regulations: LSA Code II/2.3.1.3.4; MSC.81(70) 1/3.1.12</b>																																										
Test Procedure	Acceptance Criteria	Significant Test Data																																										
<p>All test subjects, each wearing a lifejacket but not the immersion suit, should attempt to swim 25 m and board a liferaft or rigid platform with its surface 300 mm above the water surface.</p> <p>Test subjects who successfully complete this task should also perform it wearing the immersion suit.</p> <p>If designed to be used with a lifejacket, then immersion suit should be tested with the subject also wearing a lifejacket.</p>	<p>All qualified test subjects should be able to board the liferaft or platform while wearing the immersion suit.</p>	<p>1) 25m swim and boarding without lifejacket.</p> <table style="width:100%; border: none;"> <tr> <td></td> <td style="text-align: center;">Pass</td> <td style="text-align: center;">Fail</td> </tr> <tr> <td>Subject No.1</td> <td style="text-align: center;">_____</td> <td style="text-align: center;">_____</td> </tr> <tr> <td>Subject No.2</td> <td style="text-align: center;">_____</td> <td style="text-align: center;">_____</td> </tr> <tr> <td>Subject No.3</td> <td style="text-align: center;">_____</td> <td style="text-align: center;">_____</td> </tr> <tr> <td>Subject No.4</td> <td style="text-align: center;">_____</td> <td style="text-align: center;">_____</td> </tr> <tr> <td>Subject No.5</td> <td style="text-align: center;">_____</td> <td style="text-align: center;">_____</td> </tr> <tr> <td>Subject No.6</td> <td style="text-align: center;">_____</td> <td style="text-align: center;">_____</td> </tr> </table> <p>2) 25 m swim and boarding with immersion suit</p> <table style="width:100%; border: none;"> <tr> <td></td> <td style="text-align: center;">Pass</td> <td style="text-align: center;">Fail</td> </tr> <tr> <td>Subject No.1</td> <td style="text-align: center;">_____</td> <td style="text-align: center;">_____</td> </tr> <tr> <td>Subject No.2</td> <td style="text-align: center;">_____</td> <td style="text-align: center;">_____</td> </tr> <tr> <td>Subject No.3</td> <td style="text-align: center;">_____</td> <td style="text-align: center;">_____</td> </tr> <tr> <td>Subject No.4</td> <td style="text-align: center;">_____</td> <td style="text-align: center;">_____</td> </tr> <tr> <td>Subject No.5</td> <td style="text-align: center;">_____</td> <td style="text-align: center;">_____</td> </tr> <tr> <td>Subject No.6</td> <td style="text-align: center;">_____</td> <td style="text-align: center;">_____</td> </tr> </table> <p>Comments/Observations</p>		Pass	Fail	Subject No.1	_____	_____	Subject No.2	_____	_____	Subject No.3	_____	_____	Subject No.4	_____	_____	Subject No.5	_____	_____	Subject No.6	_____	_____		Pass	Fail	Subject No.1	_____	_____	Subject No.2	_____	_____	Subject No.3	_____	_____	Subject No.4	_____	_____	Subject No.5	_____	_____	Subject No.6	_____	_____
	Pass	Fail																																										
Subject No.1	_____	_____																																										
Subject No.2	_____	_____																																										
Subject No.3	_____	_____																																										
Subject No.4	_____	_____																																										
Subject No.5	_____	_____																																										
Subject No.6	_____	_____																																										
	Pass	Fail																																										
Subject No.1	_____	_____																																										
Subject No.2	_____	_____																																										
Subject No.3	_____	_____																																										
Subject No.4	_____	_____																																										
Subject No.5	_____	_____																																										
Subject No.6	_____	_____																																										

<b>Immersion suits (insulated)</b>	Manufacturer: _____ Model: _____ Lot/Serial Number: _____	Date: _____ Time: _____ Surveyor: _____ Organization: _____																					
<b>2.3.2.17 Oil resistance test</b>		<b>Regulations: LSA Code; MSC.81(70) 1/3.1.13</b>																					
Test Procedure	Acceptance Criteria	Significant Test Data																					
<p>After all its apertures have been sealed an immersion suit should be immersed for a period of 24 h under 100 mm head of diesel oil at normal room temperature.</p> <p>The surface oil should then be wiped off and the immersion suit subjected to the test prescribed in 2.3.1.15.</p>	<p>The ingress of water should not exceed a mass of 200g.</p>	<p>Indicate which alternative is used.  <input type="checkbox"/>Alternative 1 <input type="checkbox"/>Alternative 2</p> <p>Water ingress <math>\leq</math> 200g</p> <table style="width:100%; border: none;"> <tr> <td style="width:60%;"></td> <td style="text-align: center;">Pass</td> <td style="text-align: center;">Fail</td> </tr> <tr> <td>Subject No.1</td> <td style="text-align: center;">_____</td> <td style="text-align: center;">_____</td> </tr> <tr> <td>Subject No.2</td> <td style="text-align: center;">_____</td> <td style="text-align: center;">_____</td> </tr> <tr> <td>Subject No.3</td> <td style="text-align: center;">_____</td> <td style="text-align: center;">_____</td> </tr> <tr> <td>Subject No.4</td> <td style="text-align: center;">_____</td> <td style="text-align: center;">_____</td> </tr> <tr> <td>Subject No.5</td> <td style="text-align: center;">_____</td> <td style="text-align: center;">_____</td> </tr> <tr> <td>Subject No.6</td> <td style="text-align: center;">_____</td> <td style="text-align: center;">_____</td> </tr> </table> <p>Comments/Observations</p>		Pass	Fail	Subject No.1	_____	_____	Subject No.2	_____	_____	Subject No.3	_____	_____	Subject No.4	_____	_____	Subject No.5	_____	_____	Subject No.6	_____	_____
	Pass	Fail																					
Subject No.1	_____	_____																					
Subject No.2	_____	_____																					
Subject No.3	_____	_____																					
Subject No.4	_____	_____																					
Subject No.5	_____	_____																					
Subject No.6	_____	_____																					

<b>Immersion suits (insulated)</b>	Manufacturer: _____ Model: _____ Lot/Serial Number: _____	Date: _____ Time: _____ Surveyor: _____ Organization: _____																					
<b>2.3.2.18 Alternative oil resistance test</b>		<b>Regulations: LSA Code; MSC.81(70) 1/3.1.14</b>																					
Test Procedure	Acceptance Criteria	Significant Test Data																					
<p>In lieu of the test for oil resistance prescribed in 2.3.2.17 either of the following tests may be conducted.</p> <p>After all apertures have been sealed, the immersion suit should be immersed for a period of 24 h under 100 mm head of diesel oil at normal room temperature if necessary using weights to keep suit submerged. Any surface oil should then be wiped off and the immersion suit turned inside out. The suit should then be laid on a table suitable for collecting and draining off any leakage and be supported at the neck aperture by a suitable designed hanger. The suit should then be filled with water to neck level which should be 300mm above the table.</p> <p>Representative samples of the exterior fabric and seams should be immersed under 100mm head of diesel oil for 24 h. After removal from the oil the samples should be wiped off before being subjected to the following tests:</p> <p>.1 a hydrostatic test of a 1m water head and</p> <p>.2 a tensile test of representative seams</p>	<p>After 1h in this position there should be no leakage exceeding a mass of 200g.</p> <p>The samples should successfully support 1 m head of water.</p> <p>The seam strength should be not less than 150 N.</p>	<p>Indicate which alternative is used.  <input type="checkbox"/>Alternative 1 <input type="checkbox"/>Alternative 2</p> <p>Water ingress ≤ 200g</p> <table style="width:100%; border: none;"> <tr> <td style="width:60%;"></td> <td style="text-align: center;">Pass</td> <td style="text-align: center;">Fail</td> </tr> <tr> <td>Subject No.1</td> <td style="text-align: center;">_____</td> <td style="text-align: center;">_____</td> </tr> <tr> <td>Subject No.2</td> <td style="text-align: center;">_____</td> <td style="text-align: center;">_____</td> </tr> <tr> <td>Subject No.3</td> <td style="text-align: center;">_____</td> <td style="text-align: center;">_____</td> </tr> <tr> <td>Subject No.4</td> <td style="text-align: center;">_____</td> <td style="text-align: center;">_____</td> </tr> <tr> <td>Subject No.5</td> <td style="text-align: center;">_____</td> <td style="text-align: center;">_____</td> </tr> <tr> <td>Subject No.6</td> <td style="text-align: center;">_____</td> <td style="text-align: center;">_____</td> </tr> </table> <p>Strength &gt; 150N    Pass                  Fail</p> <p>The samples should support a 1 m head of water</p> <p style="text-align: center;">Pass _____ Fail _____</p> <p>Comments/Observations</p>		Pass	Fail	Subject No.1	_____	_____	Subject No.2	_____	_____	Subject No.3	_____	_____	Subject No.4	_____	_____	Subject No.5	_____	_____	Subject No.6	_____	_____
	Pass	Fail																					
Subject No.1	_____	_____																					
Subject No.2	_____	_____																					
Subject No.3	_____	_____																					
Subject No.4	_____	_____																					
Subject No.5	_____	_____																					
Subject No.6	_____	_____																					

<b>Immersion suits (insulated)</b>	Manufacturer: _____ Model: _____ Lot/Serial Number: _____	Date: _____ Time: _____ Surveyor: _____ Organization: _____
<b>2.3.2.19 Fire test</b>		<b>Regulations: LSA Code II/2.3.1.1.2; MSC.81(70) 1/3.1.15</b>
<b>Test Procedure</b>	<b>Acceptance Criteria</b>	<b>Significant Test Data</b>
<p>A test pan 30 cm x 35 cm x 6 cm should be placed in an essentially draught-free area. Water should be put in the bottom of the test pan to make a minimum total depth of 1 cm followed by enough petrol to make a minimum depth of 4 cm. The petrol should then be ignited and allowed to burn freely for 30 s. If necessary, the immersion suit should be draped over a hanger to ensure the whole of the suit is enveloped in the flames, with the bottom of the suit 25 cm above the top edge of the test pan so that the duration of exposure to the flames is 2 s.</p>	<p>The immersion suit should not sustain burning for more than 6 s or continue melting after being removed from exposure to the flames.</p>	<p>Did the immersion suit continue to burn for more than 6 s or continue melting after being removed from the flames?</p> <p style="text-align: center;"><input type="checkbox"/> YES   <input type="checkbox"/> NO</p> <p>Comments/Observations</p>

<b>Immersion suits (insulated)</b>	Manufacturer: _____ Model: _____ Lot/Serial Number: _____	Date: _____ Time: _____ Surveyor: _____ Organization: _____
<b>2.3.2.20 Temperature cycling test</b>		<b>Regulations: LSA Code I/1.2.2.2; MSC.81(70) 1/3.1.16</b>
Test Procedure	Acceptance Criteria	Significant Test Data
<p>The following test should be carried out on two immersion suits.</p> <p>The immersion suits should be alternately subjected to surrounding temperatures of -30°C and +65°C. These alternating cycles need not follow immediately after each other and the following procedure, repeated for a total of 10 cycles, is acceptable:</p> <p>.1 an 8 h exposure at a minimum temperature of +65°C to be completed in one day; and</p> <p>.2 the specimens removed from the warm chamber that same day and left exposed under ordinary room conditions at a temperature of 20°C ± 3°C until the next day;</p> <p>.3 an 8 h exposure at a maximum temperature of -30°C to be completed the next day; and</p> <p>.4 the specimens removed from the cold chamber that same day and left exposed under ordinary room conditions at a temperature of 20°C ± 3°C until the next day.</p>	<p>The immersion suits should show no signs of damage such as shrinking, swelling dissolution or changes of mechanical qualities.</p>	<p>(See following page for test data)</p> <p>Passed _____ Failed _____</p> <p>Comments/Observations</p>

<b>Immersion suits (insulated)</b>	Manufacturer: _____		Date: _____ Time: _____	
	Model: _____		Surveyor: _____	
	Lot/Serial Number: _____		Organization: _____	
<b>2.3.2.21 Temperature cycling test - Test data</b>			<b>Regulations: LSA Code I/1.2.1.2; MSC.81(70) 1/3.1.16</b>	
	<b>HOT CYCLE</b>		<b>COLD CYCLE</b>	
Cycle 1	Date In: _____ Time In: _____ Temperature: _____ °C	Date Out: _____ Time Out: _____ Duration: _____ hours	Date In: _____ Time In: _____ Temperature: _____ °C	Date Out: _____ Time Out: _____ Duration: _____ hours
Cycle 2	Date In: _____ Time In : _____ Temperature : _____ °C	Date Out: _____ Time Out: _____ Duration: _____ hours	Date In: _____ Time In: _____ Temperature: _____ °C	Date Out: _____ Time Out: _____ Duration: _____ hours
Cycle 3	Date In: _____ Time In: _____ Temperature: _____ °C	Date Out: _____ Time Out: _____ Duration : _____ hours	Date In: _____ Time In: _____ Temperature: _____ °C	Date Out: _____ Time Out: _____ Duration: _____ hours
Cycle 4	Date In: _____ Time In: _____ Temperature: _____ °C	Date Out: _____ Time Out: _____ Duration: _____ hours	Date In: _____ Time In: _____ Temperature: _____ °C	Date Out: _____ Time Out: _____ Duration: _____ hours
Cycle 5	Date In: _____ Time In: _____ Temperature: _____ °C	Date Out: _____ Time Out: _____ Duration : _____ hours	Date In: _____ Time In: _____ Temperature: _____ °C	Date Out: _____ Time Out: _____ Duration: _____ hours
Cycle 6	Date In: _____ Time In: _____ Temperature: _____ °C	Date Out: _____ Time Out: _____ Duration: _____ hours	Date In: _____ Time In: _____ Temperature: _____ °C	Date Out: _____ Time Out: _____ Duration: _____ hours
Cycle 7	Date In: _____ Time In: _____ Temperature: _____ °C	Date Out: _____ Time Out: _____ Duration : _____ hours	Date In: _____ Time In: _____ Temperature: _____ °C	Date Out: _____ Time Out: _____ Duration: _____ hours
Cycle 8	Date In: _____ Time In: _____ Temperature: _____ °C	Date Out: _____ Time Out: _____ Duration : _____ hours	Date In: _____ Time In: _____ Temperature: _____ °C	Date Out: _____ Time Out: _____ Duration: _____ hours
Cycle 9	Date In: _____ Time In: _____ Temperature: _____ °C	Date Out: _____ Time Out: _____ Duration: _____ hours	Date In: _____ Time In: _____ Temperature: _____ °C	Date Out: _____ Time Out: _____ Duration: _____ hours
Cycle 10	Date In: _____ Time In: _____ Temperature: _____ °C	Date Out: _____ Time Out: _____ Duration: _____ hours	Date In: _____ Time In: _____ Temperature: _____ °C	Date Out: _____ Time Out: _____ Duration: _____ hours

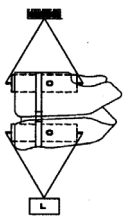
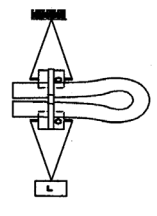
<b>Immersion suits (insulated)</b>	Manufacturer: _____ Model: _____ Lot/Serial Number: _____	Date: _____ Time: _____ Surveyor: _____ Organization: _____
<b>2.3.2.22 Buoyancy test</b>		<b>Regulations: LSA Code II/2.3.1.8; MSC.81(70) 1/3.1.17</b>
Test Procedure	Acceptance Criteria	Significant Test Data
The buoyancy of an immersion suit designed to be worn without a lifejacket should be measured before and after 24 h complete submersion to just below the surface in fresh water.	The difference between the initial buoyancy and the final buoyancy should not exceed 5% of the initial buoyancy	Buoyancy 1    Buoyancy 2    %difference _____kg    _____kg _____% Passed _____ Failed Comments/Observations
<b>2.3.2.23 Strength test</b>		<b>Regulations: LSA Code; MSC.81(70) 1/3.1.18</b>
Test Procedure	Acceptance Criteria	Significant Test Data
The immersion suit should be immersed in water for a period of 2 min. It should then be removed from the water and closed in the same manner as when worn by a person. A force of not less than 3200 N should be applied to the lifting loop and a force of not less than 1350N should be applied to the parts other than the lifting loop for 30 min.  The immersion suit may be cut if necessary to accommodate to the test device.	The immersion suit should not be damaged as a result of this test.  <div style="display: flex; justify-content: space-around; align-items: center;"> <div style="text-align: center;">               Vest-type lifejacket           </div> <div style="text-align: center;">               Yoke or over-the-head type lifejacket           </div> </div>	Passed _____    Failed _____  Comments/Observations

<b>Immersion suits (insulated)</b>	Manufacturer: _____ Model: _____ Lot/Serial Number: _____	Date: _____ Time: _____ Surveyor: _____ Organization: _____
<b>2.3.2.24 Thermal protective test (General)</b>		<b>Regulations: LSA Code II/2.3.2.2; MSC.81(70) 1/3.2.1 – 3.2.5</b>
Test Procedure	Acceptance Criteria	Significant Test Data
<p>The thermal protective qualities may be measured using a thermal manikin, when such a method is required by an Administration and has been demonstrated to provide test results which correlate satisfactorily in all aspects to test results using human subjects.</p> <p>If human subjects are used, they should be medically examined before being accepted for the tests. Each design of immersion suit is to be tested by test subjects specified in 2.3.2.5.</p> <p>Where human subjects are used, the tests should always be conducted under the supervision of physician. Emergency resuscitation equipment should be available during all tests. For safety reasons, ECG should be monitored during every test. Testing should be stopped at the wish of the test subjects, if the falling rate of the core temperature is more than 1.5°C per hour after the first half hour, if the skin temperature of the hand, foot or lumbar region should fall below 10° C, or if the attending physician considers it advisable.</p> <p>When testing with human subjects, continuous body core temperature (rectal temperature) and skin temperature of lumbar region, both hands, calves, foot (foot instep) and heels, should be measured. The accuracy of the measuring system should be ±0.2°C. Appropriate corresponding measurements should be taken if a manikin is used in lieu of human subjects.</p>		Comments/Observations



<b>Immersion suits (insulated)</b>	Manufacturer: _____ Model: _____ Lot/Serial Number: _____	Date: _____ Time: _____ Surveyor: _____ Organization: _____																																							
<b>2.3.2.25 Thermal Protective test (Continued)</b>		<b>Regulations: LSA Code II/2.3.2.2; MSC.81(70) 1/, 3.2.11 &amp; 3.2.12</b>																																							
Test Procedure	Acceptance Criteria	Significant Test Data																																							
<p>Prior to tests, the same amount of water resulting from the water ingress and jump test in paragraph 2.3.2.13 should be poured into the dry suit worn over the dry test clothing specified in 2.3.2.7 by the test subject lying down.</p> <p>Each test subject wearing an immersion suit previously subjected to the jump test in paragraph 2.3.2.14. Following a 6 h period of immersion, with hands gloved, in circulating calm water at between 0°C and +2°C, each test subject's body core temperature should not fall more than 2°C below the normal level of the subject's temperature.</p> <p>The immersion suit should provide sufficient thermal protection to ensure that immediately on leaving the water after a 1 hr period of immersion, with gloved hands, in water circulating at +5°C each test subject can pick up a pencil as specified in paragraph 2.3.2.9 and write.</p> <p>Alternatively, at the manufacturers' option, the ability to pick up a pencil and write as specified in paragraph 2.3.2.9 above may be demonstrated immediately after leaving the water upon completion of the above (6 hr) test.</p>	<p>Same mass of water which was the result from test 2.3.2.13, should be poured into the immersion suit.</p> <p>Following immersion each test subject's body core temperature should not fall more than 2°C below the normal level of the subject's temperature.</p> <p>The test subjects should be able to pick up a pencil and write.</p> <p>See attached test sheets for temperatures during the immersion tests:</p> <p>Comments/Observations</p>	<p>Same mass of water which was the result from test 2.3.2.13, should be poured into the immersion suit</p> <table style="width:100%; border: none;"> <tr> <td style="text-align: center;">Beginning of test</td> <td style="text-align: center;">End of test</td> <td style="text-align: center;">normal temperature</td> </tr> </table> <p>Subject No 1 Subject No.2 Subject No.3 Subject No.4 Subject No.5 Subject No.6</p> <p>Passed _____ Failed _____</p> <p>Pick up a pencil and write after 1 h period of immersion:</p> <table style="width:100%; border: none;"> <tr> <td>Subject No 1</td> <td><input type="checkbox"/>YES</td> <td><input type="checkbox"/>NO</td> </tr> <tr> <td>Subject No 2</td> <td><input type="checkbox"/>YES</td> <td><input type="checkbox"/>NO</td> </tr> <tr> <td>Subject No 3</td> <td><input type="checkbox"/>YES</td> <td><input type="checkbox"/>NO</td> </tr> <tr> <td>Subject No 4</td> <td><input type="checkbox"/>YES</td> <td><input type="checkbox"/>NO</td> </tr> <tr> <td>Subject No 5</td> <td><input type="checkbox"/>YES</td> <td><input type="checkbox"/>NO</td> </tr> <tr> <td>Subject No 6</td> <td><input type="checkbox"/>YES</td> <td><input type="checkbox"/>NO</td> </tr> </table> <p>Passed _____ Failed _____</p> <p>Pick up a pencil and write after 6 h period of immersion:</p> <table style="width:100%; border: none;"> <tr> <td>Subject No 1</td> <td><input type="checkbox"/>YES</td> <td><input type="checkbox"/>NO</td> </tr> <tr> <td>Subject No 2</td> <td><input type="checkbox"/>YES</td> <td><input type="checkbox"/>NO</td> </tr> <tr> <td>Subject No 3</td> <td><input type="checkbox"/>YES</td> <td><input type="checkbox"/>NO</td> </tr> <tr> <td>Subject No 4</td> <td><input type="checkbox"/>YES</td> <td><input type="checkbox"/>NO</td> </tr> <tr> <td>Subject No 5</td> <td><input type="checkbox"/>YES</td> <td><input type="checkbox"/>NO</td> </tr> <tr> <td>Subject No 6</td> <td><input type="checkbox"/>YES</td> <td><input type="checkbox"/>NO</td> </tr> </table> <p>Passed _____ Failed _____</p>	Beginning of test	End of test	normal temperature	Subject No 1	<input type="checkbox"/> YES	<input type="checkbox"/> NO	Subject No 2	<input type="checkbox"/> YES	<input type="checkbox"/> NO	Subject No 3	<input type="checkbox"/> YES	<input type="checkbox"/> NO	Subject No 4	<input type="checkbox"/> YES	<input type="checkbox"/> NO	Subject No 5	<input type="checkbox"/> YES	<input type="checkbox"/> NO	Subject No 6	<input type="checkbox"/> YES	<input type="checkbox"/> NO	Subject No 1	<input type="checkbox"/> YES	<input type="checkbox"/> NO	Subject No 2	<input type="checkbox"/> YES	<input type="checkbox"/> NO	Subject No 3	<input type="checkbox"/> YES	<input type="checkbox"/> NO	Subject No 4	<input type="checkbox"/> YES	<input type="checkbox"/> NO	Subject No 5	<input type="checkbox"/> YES	<input type="checkbox"/> NO	Subject No 6	<input type="checkbox"/> YES	<input type="checkbox"/> NO
Beginning of test	End of test	normal temperature																																							
Subject No 1	<input type="checkbox"/> YES	<input type="checkbox"/> NO																																							
Subject No 2	<input type="checkbox"/> YES	<input type="checkbox"/> NO																																							
Subject No 3	<input type="checkbox"/> YES	<input type="checkbox"/> NO																																							
Subject No 4	<input type="checkbox"/> YES	<input type="checkbox"/> NO																																							
Subject No 5	<input type="checkbox"/> YES	<input type="checkbox"/> NO																																							
Subject No 6	<input type="checkbox"/> YES	<input type="checkbox"/> NO																																							
Subject No 1	<input type="checkbox"/> YES	<input type="checkbox"/> NO																																							
Subject No 2	<input type="checkbox"/> YES	<input type="checkbox"/> NO																																							
Subject No 3	<input type="checkbox"/> YES	<input type="checkbox"/> NO																																							
Subject No 4	<input type="checkbox"/> YES	<input type="checkbox"/> NO																																							
Subject No 5	<input type="checkbox"/> YES	<input type="checkbox"/> NO																																							
Subject No 6	<input type="checkbox"/> YES	<input type="checkbox"/> NO																																							

---

<b>2.3.2.25 Thermal Protective test (Continued)</b>	<b>Regulations: LSA Code II/2.3.2.2; MSC.81(70) 1/, 3.2.11 &amp; 3.2.12</b>	
Test Procedure	Acceptance Criteria	Significant Test Data
		See attached test sheets for temperatures during the immersion tests:  Comments/Observations

<b>Immersion suits (insulated)</b>	Manufacturer: _____ Model: _____ Lot/Serial Number: _____	Date: _____ Time: _____ Surveyor: _____ Organization: _____				
<b>2.3.2.26 Test sheets for temperatures during immersion tests</b>		<b>Regulations: LSA Code II/2.3.2.2; MSC.81(70) 1/, 3.2.11 &amp; 3.2.12</b>				
<b>Subject 1</b>	Rectal temp after 1 hr: _____ Skin temp at lumbar region after 1 hr : _____ Skin temp at left hand after 1 hr: _____ Skin temp at right hand after 1 hr: _____ Skin temp at calves after 1 hr: _____ Skin temp at left foot (foot instep) after 1 hr: _____ Skin temp at right foot (foot instep) after 1 hr: _____ Skin temp at left heel after 1 hr: _____	Rectal temp after 2 hr: _____ Skin temp at lumbar region after 2 hr: _____ Skin temp at left hand after 2 hr: _____ Skin temp at right hand after 2 hr: _____ Skin temp at calves after 2 hr: _____ Skin temp at left foot (foot instep) after 2 hr: _____ Skin temp at right foot (foot instep) after 2 hr: _____ Skin temp at left heel after 2 hr: _____	Rectal temp after 3 hr: _____ Skin temp at lumbar region after 3 hr : _____ Skin temp at left hand after 3 hr: _____ Skin temp at right hand after 3 hr: _____ Skin temp at calves after 3 hr: _____ Skin temp at left foot (foot instep) after 3 hr: _____ Skin temp at right foot (foot instep) after 3 hr: _____ Skin temp at left heel after 3 hr: _____	Rectal temp after 4 hr: _____ Skin temp at lumbar region after 4 hr : _____ Skin temp at left hand after 4 hr: _____ Skin temp at right hand after 4 hr: _____ Skin temp at calves after 4 hr: _____ Skin temp at left foot (foot instep) after 4 hr: _____ Skin temp at right foot (foot instep) after 4 hr: _____ Skin temp at left heel after 4 hr: _____	Rectal temp after 5 hr: _____ Skin temp at lumbar region after 5 hr: _____ Skin temp at left hand after 5 hr: _____ Skin temp at right hand after 5 hr: _____ Skin temp at calves after 5 hr: _____ Skin temp at left foot (foot instep) after 5 hr: _____ Skin temp at right foot (foot instep) after 5 hr: _____ Skin temp at left heel after 5 hr: _____	Rectal temp after 6 hr: _____ Skin temp at lumbar region after 6 hr : _____ Skin temp at left hand after 6 hr: _____ Skin temp at right hand after 6 hr: _____ Skin temp at calves after 6 hr: _____ Skin temp at left foot (foot instep) after 6 hr: _____ Skin temp at right foot (foot instep) after 6 hr: _____ Skin temp at left heel after 6 hr: _____
	<b>Subject 2</b>	Rectal temp after 1 hr: _____ Skin temp at lumbar region after 1 hr : _____ Skin temp at left hand after 1 hr: _____ Skin temp at right hand after 1 hr: _____ Skin temp at calves after 1 hr: _____ Skin temp at left foot (foot instep) after 1 hr: _____ Skin temp at right foot (foot instep) after 1 hr: _____ Skin temp at left heel after 1 hr: _____	Rectal temp after 2 hr: _____ Skin temp at lumbar region after 2 hr : _____ Skin temp at left hand after 2 hr: _____ Skin temp at right hand after 2 hr: _____ Skin temp at calves after 2 hr: _____ Skin temp at left foot (foot instep) after 2 hr: _____ Skin temp at right foot (foot instep) after 2 hr: _____ Skin temp at left heel after 2hr: _____	Rectal temp after 3 hr: _____ Skin temp at lumbar region after 3 hr : _____ Skin temp at left hand after 3 hr: _____ Skin temp at right hand after 3 hr: _____ Skin temp at calves after 3 hr: _____ Skin temp at left foot (foot instep) after 3 hr: _____ Skin temp at right foot (foot instep) after 3 hr: _____ Skin temp at left heel after 3 hr: _____	Rectal temp after 4 hr: _____ Skin temp at lumbar region after 4 hr : _____ Skin temp at left hand after 4 hr: _____ Skin temp at right hand after 4 hr: _____ Skin temp at calves after 4 hr: _____ Skin temp at left foot (foot instep) after 4 hr: _____ Skin temp at right foot (foot instep) after 4 hr: _____ Skin temp at left heel after 4 hr: _____	Rectal temp after 5 hr: _____ Skin temp at lumbar region after 5 hr : _____ Skin temp at left hand after 5 hr: _____ Skin temp at right hand after 5 hr: _____ Skin temp at calves after 5 hr: _____ Skin temp at left foot (foot instep) after 5 hr: _____ Skin temp at right foot (foot instep) after 5 hr: _____ Skin temp at left heel after 5 hr: _____

<b>Immersion suits (insulated)</b>	Manufacturer: _____ Model: _____ Lot/Serial Number: _____	Date: _____ Time: _____ Surveyor: _____ Organization: _____
<b>2.3.2.26 Test sheets for temperatures during immersion tests (continued)</b>		<b>Regulations: LSA Code II/2.3.2.2; MSC.81(70) 1/, 3.2.11 &amp; 3.2.12</b>
<b>Subject 3</b>	Rectal temp after 1 hr: _____ Skin temp at lumbar region after 1 hr : _____ Skin temp at left hand after 1 hr: _____ Skin temp at right hand after 1 hr: _____ Skin temp at calves after 1 hr: _____ Skin temp at left foot (foot instep) after 1 hr: _____ Skin temp at right foot (foot instep) after 1 hr: _____ Skin temp at left heel after 1 hr: _____	Rectal temp after 2 hr: _____ Skin temp at lumbar region after 2 hr : _____ Skin temp at left hand after 2 hr: _____ Skin temp at right hand after 2 hr: _____ Skin temp at calves after 2 hr: _____ Skin temp at left foot (foot instep) after 2 hr: _____ Skin temp at right foot (foot instep) after 2 hr: _____ Skin temp at left heel after 2 r: _____
	Rectal temp after 3 hr: _____ Skin temp at lumbar region after 3 hr : _____ Skin temp at left hand after 3 hr: _____ Skin temp at right hand after 3 hr: _____ Skin temp at calves after 3 hr: _____ Skin temp at left foot (foot instep) after 3 hr: _____ Skin temp at right foot (foot instep) after 3 hr: _____ Skin temp at left heel after 3 hr: _____	Rectal temp after 4 hr: _____ Skin temp at lumbar region after 4 hr : _____ Skin temp at left hand after 4 hr: _____ Skin temp at right hand after 4 hr: _____ Skin temp at calves after 4 hr: _____ Skin temp at left foot (foot instep) after 4 hr: _____ Skin temp at right foot (foot instep) after 4 hr: _____ Skin temp at left heel after 4 hr: _____
<b>Subject 4</b>	Rectal temp after 1 hr: _____ Skin temp at lumbar region after 1 hr : _____ Skin temp at left hand after 1 hr: _____ Skin temp at right hand after 1 hr: _____ Skin temp at calves after 1 hr: _____ Skin temp at left foot (foot instep) after 1 hr: _____ Skin temp at right foot (foot instep) after 1 hr: _____ Skin temp at left heel after 1 hr: _____	Rectal temp after 2 hr: _____ Skin temp at lumbar region after 2 hr : _____ Skin temp at left hand after 2 hr: _____ Skin temp at right hand after 2 hr: _____ Skin temp at calves after 2 hr: _____ Skin temp at left foot (foot instep) after 2 hr: _____ Skin temp at right foot (foot instep) after 2 hr: _____ Skin temp at left heel after 2hr: _____
	Rectal temp after 3 hr: _____ Skin temp at lumbar region after 3 hr : _____ Skin temp at left hand after 3 hr: _____ Skin temp at right hand after 3 hr: _____ Skin temp at calves after 3 hr: _____ Skin temp at left foot (foot instep) after 3 hr: _____ Skin temp at right foot (foot instep) after 3 hr: _____ Skin temp at left heel after 3 hr: _____	Rectal temp after 4 hr: _____ Skin temp at lumbar region after 4 hr : _____ Skin temp at left hand after 4 hr: _____ Skin temp at right hand after 4 hr: _____ Skin temp at calves after 4 hr: _____ Skin temp at left foot (foot instep) after 4 hr: _____ Skin temp at right foot (foot instep) after 4 hr: _____ Skin temp at left heel after 4 hr: _____
	Rectal temp after 5 hr: _____ Skin temp at lumbar region after 5 hr : _____ Skin temp at left hand after 5 hr: _____ Skin temp at right hand after 5 hr: _____ Skin temp at calves after 5 hr: _____ Skin temp at left foot (foot instep) after 5 hr: _____ Skin temp at right foot (foot instep) after 5 hr: _____ Skin temp at left heel after 5 hr: _____	Rectal temp after 6 hr: _____ Skin temp at lumbar region after 6 hr : _____ Skin temp at left hand after 6 hr: _____ Skin temp at right hand after 6 hr: _____ Skin temp at calves after 6 hr: _____ Skin temp at left foot (foot instep) after 6 hr: _____ Skin temp at right foot (foot instep) after 6 hr: _____ Skin temp at left heel after 6 hr: _____

<b>Immersion suits (insulated)</b>	Manufacturer: _____ Model: _____ Lot/Serial Number: _____	Date: _____ Time: _____ Surveyor: _____ Organization: _____				
<b>2.3.2.26 Test sheets for temperatures during immersion tests (continued)</b>		<b>Regulations: LSA Code II/2.3.2.2; MSC.81(70) 1/, 3.2.11 &amp; 3.2.12</b>				
<b>Subject 5</b>	Rectal temp after 1 hr: _____ Skin temp at lumbar region after 1 hr : _____ Skin temp at left hand after 1 hr: _____ Skin temp at right hand after 1 hr: _____ Skin temp at calves after 1 hr: _____ Skin temp at left foot (foot instep) after 1 hr: _____ Skin temp at right foot (foot instep) after 1 hr: _____ Skin temp at left heel after 1 hr: _____	Rectal temp after 2 hr: _____ Skin temp at lumbar region after 2 hr : _____ Skin temp at left hand after 2 hr: _____ Skin temp at right hand after 2 hr: _____ Skin temp at calves after 2 hr: _____ Skin temp at left foot (foot instep) after 2 hr: _____ Skin temp at right foot (foot instep) after 2 hr: _____ Skin temp at left heel after 2 hr: _____	Rectal temp after 3 hr: _____ Skin temp at lumbar region after 3 hr : _____ Skin temp at left hand after 3 hr: _____ Skin temp at right hand after 3 hr: _____ Skin temp at calves after 3 hr: _____ Skin temp at left foot (foot instep) after 3 hr: _____ Skin temp at right foot (foot instep) after 3 hr: _____ Skin temp at left heel after 3 hr: _____	Rectal temp after 4 hr: _____ Skin temp at lumbar region after 4 hr : _____ Skin temp at left hand after 4 hr: _____ Skin temp at right hand after 4 hr: _____ Skin temp at calves after 4 hr: _____ Skin temp at left foot (foot instep) after 4 hr: _____ Skin temp at right foot (foot instep) after 4 hr: _____ Skin temp at left heel after 4 hr: _____	Rectal temp after 5 hr: _____ Skin temp at lumbar region after 5 hr : _____ Skin temp at left hand after 5 hr: _____ Skin temp at right hand after 5 hr: _____ Skin temp at calves after 5 hr: _____ Skin temp at left foot (foot instep) after 5 hr: _____ Skin temp at right foot (foot instep) after 5 hr: _____ Skin temp at left heel after 5 hr: _____	Rectal temp after 6 hr: _____ Skin temp at lumbar region after 6 hr : _____ Skin temp at left hand after 6 hr: _____ Skin temp at right hand after 6 hr: _____ Skin temp at calves after 6 hr: _____ Skin temp at left foot (foot instep) after 6 hr: _____ Skin temp at right foot (foot instep) after 6 hr: _____ Skin temp at left heel after 6 hr: _____
	<b>Subject 6</b>	Rectal temp after 1 hr: _____ Skin temp at lumbar region after 1 hr : _____ Skin temp at left hand after 1 hr: _____ Skin temp at right hand after 1 hr: _____ Skin temp at calves after 1 hr: _____ Skin temp at left foot (foot instep) after 1 hr: _____ Skin temp at right foot (foot instep) after 1 hr: _____ Skin temp at left heel after 1 hr: _____	Rectal temp after 2 hr: _____ Skin temp at lumbar region after 2 hr: _____ Skin temp at left hand after 2 hr: _____ Skin temp at right hand after 2 hr: _____ Skin temp at calves after 2 hr: _____ Skin temp at left foot (foot instep) after 2 hr: _____ Skin temp at right foot (foot instep) after 2 hr: _____ Skin temp at left heel after 2 hr: _____	Rectal temp after 3 hr: _____ Skin temp at lumbar region after 3 hr : _____ Skin temp at left hand after 3 hr: _____ Skin temp at right hand after 3 hr: _____ Skin temp at calves after 3 hr: _____ Skin temp at left foot (foot instep) after 3 hr: _____ Skin temp at right foot (foot instep) after 3 hr: _____ Skin temp at left heel after 3 hr: _____	Rectal temp after 4 hr: _____ Skin temp at lumbar region after 4 hr : _____ Skin temp at left hand after 4 hr: _____ Skin temp at right hand after 4 hr: _____ Skin temp at calves after 4 hr: _____ Skin temp at left foot (foot instep) after 4 hr: _____ Skin temp at right foot (foot instep) after 4 hr: _____ Skin temp at left heel after 4 hr: _____	Rectal temp after 5 hr: _____ Skin temp at lumbar region after 5 hr : _____ Skin temp at left hand after 5 hr: _____ Skin temp at right hand after 5 hr: _____ Skin temp at calves after 5 hr: _____ Skin temp at left foot (foot instep) after 5 hr: _____ Skin temp at right foot (foot instep) after 5 hr: _____ Skin temp at left heel after 5 hr: _____

## **2.4 ANTI-EXPOSURE SUITS**

### **EVALUATION AND TEST REPORT**

- 2.4.1 General data and specifications
- 2.4.2 Submitted drawings, reports and documents
- 2.4.3 Quality assurance
- 2.4.4 Visual inspection
- 2.4.5 Test subjects
- 2.4.6 Test with a lifejacket
- 2.4.7 Test clothing
- 2.4.8 Donning tests 1 & 2
- 2.4.9 Ergonomic test
- 2.4.10 Field of vision test
- 2.4.11 Flotation test
- 2.4.12 Righting test
- 2.4.13 Water ingress and jump test
- 2.4.14 Jump test
- 2.4.15 Leak test
- 2.4.16 Swimming and water emergency test
- 2.4.17 Oil resistance test
- 2.4.18 Alternative oil resistance test
- 2.4.19 Fire test
- 2.4.20 Temperature cycling test
- 2.4.21 Temperature cycling test – Test data
- 2.4.22 Buoyancy test
- 2.4.23 Strength test
- 2.4.24 Thermal protective test (General)
- 2.4.25 Thermal protective test (Continued)
- 2.4.26 Test sheets for temperatures during immersion tests

**2.4 ANTI-EXPOSURE SUITS  
EVALUATION AND TEST REPORT**

<b>Manufacturer</b>	
<b>Type</b>	
<b>Date</b>	
<b>Place</b>	
<b>Name Surveyor printed</b>	
<b>Signature</b>	
<b>Approving Organization</b>	

<b>Anti-exposure suits</b>	Manufacturer: _____ Model: _____ Lot/Serial Number: _____	Date: _____ Time: _____ Surveyor: _____ Organization: _____
<b>2.4.1 General data and specifications</b>		<b>Regulations: LSA Code 2.3; MSC.81(70);</b>
<b>Construction Material:</b>  Fabric produced by: _____  Type: _____  Buoyant material produced by: _____  Type: _____	<b>Additional equipment:</b>  Retro reflective material: <input type="checkbox"/> YES <input type="checkbox"/> NO  Whistle produced: <input type="checkbox"/> YES <input type="checkbox"/> NO  Life-line: <input type="checkbox"/> YES <input type="checkbox"/> NO  Light: <input type="checkbox"/> YES <input type="checkbox"/> NO	<b>Donning instructions:</b>  <input type="checkbox"/> YES <input type="checkbox"/> NO



<b>Anti-exposure suits</b>		Manufacturer: _____ Model: _____ Lot/Serial Number: _____	Date: _____ Time: _____ Surveyor: _____ Organization: _____
<b>2.4.2 Submitted drawings, reports and documents</b>			
<b>Submitted drawings and documents</b>			<b>Status</b>
<b>Drawing No.</b>	<b>Revision No. &amp; date</b>	<b>Title of drawing</b>	
<b>Submitted reports and documents</b>			<b>Status</b>
<b>Report/Document No.</b>	<b>Revision No. &amp; date</b>	<b>Title of report / document</b>	
		Maintenance Manual -	
		Operations Manual -	

<b>Anti-exposure suits</b>	Manufacturer: _____ Model: _____ Lot/Serial Number: _____	Date: _____ Time: _____ Surveyor: _____ Organization: _____
<b>2.4.3 Quality assurance</b>		<b>Regulations: - MSC.81(70) 2/1.1, 1.2</b>
<p>Except where all appliances of a particular type are required by Chapter III of the International Convention for the Safety of Life at Sea, 1974, as amended, or the international Life-Saving Appliance (LSA) Code, to be inspected, representatives of the Administration should make random inspections of manufacturers to ensure that the quality of life-saving appliances and materials used comply with the specification of the approved prototype life-saving appliance.</p> <p>Manufacturers should be required to institute a quality control procedure to ensure that life-saving appliances are produced to the same standard as the prototype life-saving appliance approved by the Administration and to keep records of any production tests carried out in accordance with the Administration's instructions.</p>		<p>Quality Assurance</p> <p>Standard Used: - _____</p> <p>Quality Assurance Procedure: - _____</p> <p>Quality Assurance Manual: - _____</p> <p>Description of System.</p> <p>Quality Assurance System acceptable</p> <p>Yes/No</p> <p>Comments/Observations</p>

<b>Anti-exposure suits</b>	Manufacturer: _____ Model: _____ Lot/Serial Number: _____	Date: _____ Time: _____ Surveyor: _____ Organization: _____
<b>2.4.4 Visual inspection</b>		<b>Regulations: LSA Code I/1.2.2, II/2.4.1.1.3 &amp; 2.4.1.1.4</b>
Test Procedure	Acceptance Criteria	Significant Test Data
<p>Anti-Exposure suit should:</p> <p>Be clearly marked with approval information including the Administration which approved it, date of manufacturer and any operational restrictions.</p> <p>Be provided with labels giving servicing details and intervals between servicing, operating instructions, general information and manufacturers details.</p> <p>Be fitted with approved patches of retro-reflective material with a total area of at least 400 cm<sup>2</sup> and with 100 cm<sup>2</sup> on the back if the suit does not automatically turn the wearer face up according to resolution A.658(16).</p>		<p>Passed _____ Failed _____</p> <p>Passed _____ Failed _____</p> <p>Passed _____ Failed _____</p> <p>Comments/Observations</p>

2.4.4 Visual Inspection (continued)		Regulations: LSA Code I/1.2.2, II/2.4.1.3	
Test Procedure	Acceptance Criteria	Significant Test Data	
Is the anti-exposure suit of highly visible colour?	Covers the whole body except where the Administration so permits, the feet; covering for the hands and head may be provided by separate gloves and a hood, both of which shall be permanently attached to the suit.	Passed _____	Failed _____
Is the anti-exposure suit designed to be worn without a lifejacket?		Passed _____	Failed _____
If yes,	Be of international or vivid reddish orange, or a comparably highly visible colour on all parts where this will assist detection at sea.	Passed _____	Failed _____
Is the anti-exposure suit fitted with a light complying with paragraph 2.2.3 of LSA Code?		<input type="checkbox"/> YES <input type="checkbox"/> NO	
Is the anti-exposure suit fitted with a whistle complying with paragraph 2.2.1.14 of LSA Code?		Passed _____	Failed _____
Is the anti-exposure suit specified as must be worn in conjunction with a lifejacket?		Passed _____	Failed _____
Is the anti-exposure suit equipped with a pocket for a portable VHF telephone?		Passed _____	Failed _____
		Passed _____	Failed _____
		Passed _____	Failed _____
		Comments/Observations	

<b>Anti-exposure suits</b>	Manufacturer: _____ Model: _____ Lot/Serial Number: _____	Date: _____ Time: _____ Surveyor: _____ Organization: _____																																
<b>2.4.5 Test subjects</b>		<b>Regulations: LSA Code II/2.3.1.1.5 &amp; 2.3.1.3.1 - .4; MSC.81(70) 1/3.1.1 &amp; 2.8.2</b>																																
Test Procedure	Acceptance Criteria	Significant Test Data																																
<p>At least six able-bodied persons both male and females of the following heights and weights should be used. At least one and not more than two of the persons should be females with not more than one female in the same height range.</p>	<table style="width:100%; border-collapse: collapse;"> <thead> <tr> <th style="text-align:center;"><u>Height</u></th> <th style="text-align:center;"><u>Weight</u></th> </tr> </thead> <tbody> <tr> <td style="text-align:center;">1.40m - 1.60m;</td> <td style="text-align:center;">1 person under 60kg 1 person over 60kg</td> </tr> <tr> <td style="text-align:center;">1.60m - 1.80m</td> <td style="text-align:center;">1 person under 70kg 1 person over 70kg</td> </tr> <tr> <td style="text-align:center;">over 1.80m</td> <td style="text-align:center;">1 person under 80kg 1 person over 80kg</td> </tr> </tbody> </table>	<u>Height</u>	<u>Weight</u>	1.40m - 1.60m;	1 person under 60kg 1 person over 60kg	1.60m - 1.80m	1 person under 70kg 1 person over 70kg	over 1.80m	1 person under 80kg 1 person over 80kg	<table style="width:100%; border-collapse: collapse;"> <thead> <tr> <th style="text-align:center;">Male/Female</th> <th style="text-align:center;">Height</th> <th style="text-align:center;">Weight</th> </tr> </thead> <tbody> <tr> <td>Subject No.1 _____</td> <td style="text-align:center;">_____</td> <td style="text-align:center;">_____</td> </tr> <tr> <td>Subject No.2 _____</td> <td style="text-align:center;">_____</td> <td style="text-align:center;">_____</td> </tr> <tr> <td>Subject No.3 _____</td> <td style="text-align:center;">_____</td> <td style="text-align:center;">_____</td> </tr> <tr> <td>Subject No.4 _____</td> <td style="text-align:center;">_____</td> <td style="text-align:center;">_____</td> </tr> <tr> <td>Subject No.5 _____</td> <td style="text-align:center;">_____</td> <td style="text-align:center;">_____</td> </tr> <tr> <td>Subject No.6 _____</td> <td style="text-align:center;">_____</td> <td style="text-align:center;">_____</td> </tr> <tr> <td colspan="3" style="padding-top: 10px;">Comments/Observations</td> </tr> </tbody> </table>	Male/Female	Height	Weight	Subject No.1 _____	_____	_____	Subject No.2 _____	_____	_____	Subject No.3 _____	_____	_____	Subject No.4 _____	_____	_____	Subject No.5 _____	_____	_____	Subject No.6 _____	_____	_____	Comments/Observations		
<u>Height</u>	<u>Weight</u>																																	
1.40m - 1.60m;	1 person under 60kg 1 person over 60kg																																	
1.60m - 1.80m	1 person under 70kg 1 person over 70kg																																	
over 1.80m	1 person under 80kg 1 person over 80kg																																	
Male/Female	Height	Weight																																
Subject No.1 _____	_____	_____																																
Subject No.2 _____	_____	_____																																
Subject No.3 _____	_____	_____																																
Subject No.4 _____	_____	_____																																
Subject No.5 _____	_____	_____																																
Subject No.6 _____	_____	_____																																
Comments/Observations																																		
<b>2.4.6 Test with a lifejacket</b>		<b>Regulations: LSA Code II/2.3.1.5; MSC.81(70) 1/3.1.2</b>																																
Test Procedure	Acceptance Criteria	Significant Test Data																																
<p>If the anti-exposure suit is to be worn in conjunction with a lifejacket, the lifejacket should be worn over the anti-exposure suit for the tests prescribed in 2.4.8 to 2.4.16.</p>		<p>Manufacturer of lifejacket: _____          Type: _____          Manufacturer of lifejacket: _____          Type: _____</p> <p>Manufacturer of lifejacket: _____          Type: _____</p> <p>Comments/Observations</p>																																

<b>Anti-exposure suits</b>	Manufacturer: _____ Model: _____ Lot/Serial Number: _____	Date: _____ Time: _____ Surveyor: _____ Organization: _____																												
<b>2.4.7 Test clothing</b>		<b>Regulations: LSA Code II/; MSC.81(70) 1/3.2.6 &amp; 3.2.7</b>																												
Test Procedure	Acceptance Criteria	Significant Test Data																												
The test subjects should wear a standard range clothing consisting of  .1 underwear (short sleeved, short legged) .2 shirt (long sleeved) .3 trousers (not woollen, and .4 woollen socks .5 if suits to be worn in conjunction with a lifejacket, the lifejacket should be worn during the thermal protective test.		Did all test subject use the specified test clothing  <input type="checkbox"/> YES <input type="checkbox"/> NO  Comments/Observations																												
<b>2.4.8 Donning test (1)</b>		<b>Regulations: LSA Code II/2.4.1.1.4; MSC.81(70) 1/3.1.3</b>																												
Test Procedure	Acceptance Criteria	Significant Test Data																												
It can be unpacked and donned without assistance within 2 min, taking into account test clothing 2.4.7 and a lifejacket if the anti-exposure suit is to be worn in conjunction with a lifejacket.	Following a demonstration, the test subjects should be able to unpack, don and secure the anti-exposure suit over their test clothing (see 2.4.7) without assistance in less than 2 min. This time should include the time to don any associated clothing, inflate any orally inflated chambers if fitted, and don a lifejacket, if such is to be worn in conjunction with the anti-exposure suit.	<u>Donning time with normal clothing</u> <table style="width:100%; border:none;"> <thead> <tr> <th style="width:60%;"></th> <th style="width:10%; text-align:center">Time</th> <th style="width:15%; text-align:center">Pass</th> <th style="width:15%; text-align:center">Fail</th> </tr> </thead> <tbody> <tr> <td>Subject No.1 _____ sec</td> <td></td> <td style="text-align:center">_____</td> <td style="text-align:center">_____</td> </tr> <tr> <td>Subject No.2 _____ sec</td> <td></td> <td style="text-align:center">_____</td> <td style="text-align:center">_____</td> </tr> <tr> <td>Subject No.3 _____ sec</td> <td></td> <td style="text-align:center">_____</td> <td style="text-align:center">_____</td> </tr> <tr> <td>Subject No.4 _____ sec</td> <td></td> <td style="text-align:center">_____</td> <td style="text-align:center">_____</td> </tr> <tr> <td>Subject No.5 _____ sec</td> <td></td> <td style="text-align:center">_____</td> <td style="text-align:center">_____</td> </tr> <tr> <td>Subject No.6 _____ sec</td> <td></td> <td style="text-align:center">_____</td> <td style="text-align:center">_____</td> </tr> </tbody> </table> Comments/Observations		Time	Pass	Fail	Subject No.1 _____ sec		_____	_____	Subject No.2 _____ sec		_____	_____	Subject No.3 _____ sec		_____	_____	Subject No.4 _____ sec		_____	_____	Subject No.5 _____ sec		_____	_____	Subject No.6 _____ sec		_____	_____
	Time	Pass	Fail																											
Subject No.1 _____ sec		_____	_____																											
Subject No.2 _____ sec		_____	_____																											
Subject No.3 _____ sec		_____	_____																											
Subject No.4 _____ sec		_____	_____																											
Subject No.5 _____ sec		_____	_____																											
Subject No.6 _____ sec		_____	_____																											

<b>Anti-exposure suits</b>	Manufacturer: _____ Model: _____ Lot/Serial Number: _____	Date: _____ Time: _____ Surveyor: _____ Organization: _____																												
<b>2.4.8 Donning test (2)</b>		<b>Regulations: LSA Code I/2.4.1.1.4; MSC.81(70) 1/3.1.4</b>																												
Test Procedure	Acceptance Criteria	Significant Test Data																												
<p>The test subjects should be able to unpack and don in 5 mins the anti-exposure suit in ambient temperature of -30° C. Before the donning test the anti-exposure suit should be kept in a refrigerated chamber at a temperature of -30°C for 24 h.</p>	<p>The test subject should be able to complete this task in 5 min.</p>	<p><u>Donning time at - 30°C</u></p> <table style="width:100%; border-collapse: collapse;"> <thead> <tr> <th style="width:60%;"></th> <th style="width:15%;">Time</th> <th style="width:12.5%;">Pass</th> <th style="width:12.5%;">Fail</th> </tr> </thead> <tbody> <tr> <td>Subject No.1 _____ sec</td> <td>_____</td> <td>_____</td> <td>_____</td> </tr> <tr> <td>Subject No.2 _____ sec</td> <td>_____</td> <td>_____</td> <td>_____</td> </tr> <tr> <td>Subject No.3 _____ sec</td> <td>_____</td> <td>_____</td> <td>_____</td> </tr> <tr> <td>Subject No.4 _____ sec</td> <td>_____</td> <td>_____</td> <td>_____</td> </tr> <tr> <td>Subject No.5 _____ sec</td> <td>_____</td> <td>_____</td> <td>_____</td> </tr> <tr> <td>Subject No.6 _____ sec</td> <td>_____</td> <td>_____</td> <td>_____</td> </tr> </tbody> </table> <p>Comments/Observations</p>		Time	Pass	Fail	Subject No.1 _____ sec	_____	_____	_____	Subject No.2 _____ sec	_____	_____	_____	Subject No.3 _____ sec	_____	_____	_____	Subject No.4 _____ sec	_____	_____	_____	Subject No.5 _____ sec	_____	_____	_____	Subject No.6 _____ sec	_____	_____	_____
	Time	Pass	Fail																											
Subject No.1 _____ sec	_____	_____	_____																											
Subject No.2 _____ sec	_____	_____	_____																											
Subject No.3 _____ sec	_____	_____	_____																											
Subject No.4 _____ sec	_____	_____	_____																											
Subject No.5 _____ sec	_____	_____	_____																											
Subject No.6 _____ sec	_____	_____	_____																											

<b>Anti-exposure suits</b>	Manufacturer: _____ Model: _____ Lot/Serial Number: _____	Date: _____ Time: _____ Surveyor: _____ Organization: _____
<b>2.4.9 Ergonomic test</b>		<b>Regulations: LSA Code II/2.4.1.2; MSC.81(70) 1/3.1.5</b>
Test Procedure	Acceptance Criteria	Significant Test Data
<p>When wearing the anti-exposure suit, the test subjects should be able to:</p> <p>.1 climb up and down a vertical ladder of at least 5 m in length;</p> <p>.2 perform all duties associated with abandonment, assist other and operate a rescue boat; and</p> <p>.3 pick up a pencil and write. The diameter of the pencil should be 8-10 mm.</p>	<p>There should be no restriction in walking, bending over or arm movement. The diameter of the pencil should be 8-10 mm.</p>	<p>Restriction in walking, bending over or arm movement:  <input type="checkbox"/> YES <input type="checkbox"/> NO          All the test subjects were able to pick up a pencil and write: <input type="checkbox"/> YES <input type="checkbox"/> NO</p> <p>All the test subjects were able to put on the lifejacket without assistance:  <input type="checkbox"/> YES <input type="checkbox"/> NO          All the test subjects were able to perform all duties associated with abandonment, assist others and operate a rescue boat:  <input type="checkbox"/> YES <input type="checkbox"/> NO</p> <p>All the test subjects were able to climb up and down a vertical ladder of 5 meter in length:  <input type="checkbox"/> YES <input type="checkbox"/> NO          Comments/Observations</p>



<b>Anti-exposure suits</b>	Manufacturer: _____ Model: _____ Lot/Serial Number: _____	Date: _____ Time: _____ Surveyor: _____ Organization: _____																																																	
<b>2.4.10 Field of vision test</b>		<b>Regulations: LSA Code II/2.4.1.7; MSC.81(70) 1/3.1.6</b>																																																	
Test Procedure	Acceptance Criteria	Significant Test Data																																																	
Each test subject should be seated with the head in a fixed position, and the lateral field of vision measured.	The lateral field of vision should be at least 120°.	Field of vision angle $\geq 120^\circ$  <table style="width:100%; border:none;"> <thead> <tr> <th style="width:60%;"></th> <th style="width:10%;">Angle(degs.)</th> <th style="width:15%;">Pass</th> <th style="width:15%;">Fail</th> </tr> </thead> <tbody> <tr> <td>Subject No.1</td> <td>_____</td> <td>_____</td> <td>_____</td> </tr> <tr> <td>Subject No.2</td> <td>_____</td> <td>_____</td> <td>_____</td> </tr> <tr> <td>Subject No.3</td> <td>_____</td> <td>_____</td> <td>_____</td> </tr> <tr> <td>Subject No.4</td> <td>_____</td> <td>_____</td> <td>_____</td> </tr> <tr> <td>Subject No.5</td> <td>_____</td> <td>_____</td> <td>_____</td> </tr> <tr> <td>Subject No.6</td> <td>_____</td> <td>_____</td> <td>_____</td> </tr> <tr> <td colspan="4">Comments/Observations</td> </tr> </tbody> </table>		Angle(degs.)	Pass	Fail	Subject No.1	_____	_____	_____	Subject No.2	_____	_____	_____	Subject No.3	_____	_____	_____	Subject No.4	_____	_____	_____	Subject No.5	_____	_____	_____	Subject No.6	_____	_____	_____	Comments/Observations																				
	Angle(degs.)	Pass	Fail																																																
Subject No.1	_____	_____	_____																																																
Subject No.2	_____	_____	_____																																																
Subject No.3	_____	_____	_____																																																
Subject No.4	_____	_____	_____																																																
Subject No.5	_____	_____	_____																																																
Subject No.6	_____	_____	_____																																																
Comments/Observations																																																			
<b>2.4.11 Flotation test</b>		<b>Regulations: LSA Code; MSC.81(70) 1/3.1.7</b>																																																	
Test Procedure	Acceptance Criteria	Significant Test Data																																																	
	<p>When wearing the anti-exposure suit, in conjunction with a lifejacket if required, the test subject should float face-up with their mouths clear of the water by at least 120mm and be stable in that position. The freeboard should be measured from the water surface to the nose and mouth with the test subject at rest. The freeboard of the anti-exposure suit without a lifejacket should be at least 50 mm.</p> <p>The position of the lifejacket light should permit it to be visible over as great a segment of the upper hemisphere as is practicable.</p>	<table style="width:100%; border:none;"> <thead> <tr> <th rowspan="2" style="width:15%;"></th> <th colspan="2" style="width:35%;">With lifejacket</th> <th colspan="2" style="width:35%;">Without lifejacket</th> </tr> <tr> <th style="width:15%;">Mouth (mm)</th> <th style="width:15%;">Nose (mm)</th> <th style="width:15%;">Mouth (mm)</th> <th style="width:15%;">Nose (mm)</th> </tr> </thead> <tbody> <tr> <td>Freeboard</td> <td></td> <td></td> <td></td> <td></td> </tr> <tr> <td>Subject No.1</td> <td>_____</td> <td>_____</td> <td>_____</td> <td>_____</td> </tr> <tr> <td>Subject No.2</td> <td>_____</td> <td>_____</td> <td>_____</td> <td>_____</td> </tr> <tr> <td>Subject No.3</td> <td>_____</td> <td>_____</td> <td>_____</td> <td>_____</td> </tr> <tr> <td>Subject No.4</td> <td>_____</td> <td>_____</td> <td>_____</td> <td>_____</td> </tr> <tr> <td>Subject No.5</td> <td>_____</td> <td>_____</td> <td>_____</td> <td>_____</td> </tr> <tr> <td>Subject No.6</td> <td>_____</td> <td>_____</td> <td>_____</td> <td>_____</td> </tr> <tr> <td colspan="5">Comments/Observations</td> </tr> </tbody> </table>		With lifejacket		Without lifejacket		Mouth (mm)	Nose (mm)	Mouth (mm)	Nose (mm)	Freeboard					Subject No.1	_____	_____	_____	_____	Subject No.2	_____	_____	_____	_____	Subject No.3	_____	_____	_____	_____	Subject No.4	_____	_____	_____	_____	Subject No.5	_____	_____	_____	_____	Subject No.6	_____	_____	_____	_____	Comments/Observations				
	With lifejacket			Without lifejacket																																															
	Mouth (mm)	Nose (mm)	Mouth (mm)	Nose (mm)																																															
Freeboard																																																			
Subject No.1	_____	_____	_____	_____																																															
Subject No.2	_____	_____	_____	_____																																															
Subject No.3	_____	_____	_____	_____																																															
Subject No.4	_____	_____	_____	_____																																															
Subject No.5	_____	_____	_____	_____																																															
Subject No.6	_____	_____	_____	_____																																															
Comments/Observations																																																			

<b>Anti-exposure suits</b>	Manufacturer: _____ Model: _____ Lot/Serial Number: _____	Date: _____ Time: _____ Surveyor: _____ Organization: _____																												
<b>2.4.12 Righting test</b>		<b>Regulations: LSA Code II/2.4.3; MSC.81(70) 1/3.1.8</b>																												
Test Procedure	Acceptance Criteria	Significant Test Data																												
<p>Test subjects in fresh water wearing an anti-exposure suit complying with the requirements of this section should be able to turn from a face-down to a face-up position in not more than 5 s and should be stable face-up. The suit should have no tendency to turn the wearer face-down in moderate sea condition.</p>	<p>Except where it has been demonstrated that the anti-exposure suit will right the test subjects within 5 s.</p>	<p>Righting time = <math>\leq 5</math> s</p> <table style="width:100%; border-collapse: collapse;"> <thead> <tr> <th style="width:60%;"></th> <th style="width:10%;">Time (s)</th> <th style="width:15%;">Pass</th> <th style="width:15%;">Fail</th> </tr> </thead> <tbody> <tr> <td>Subject No.1</td> <td>_____</td> <td>_____</td> <td>_____</td> </tr> <tr> <td>Subject No.2</td> <td>_____</td> <td>_____</td> <td>_____</td> </tr> <tr> <td>Subject No.3</td> <td>_____</td> <td>_____</td> <td>_____</td> </tr> <tr> <td>Subject No.4</td> <td>_____</td> <td>_____</td> <td>_____</td> </tr> <tr> <td>Subject No.5</td> <td>_____</td> <td>_____</td> <td>_____</td> </tr> <tr> <td>Subject No.6</td> <td>_____</td> <td>_____</td> <td>_____</td> </tr> </tbody> </table> <p>Comments/Observations</p>		Time (s)	Pass	Fail	Subject No.1	_____	_____	_____	Subject No.2	_____	_____	_____	Subject No.3	_____	_____	_____	Subject No.4	_____	_____	_____	Subject No.5	_____	_____	_____	Subject No.6	_____	_____	_____
	Time (s)	Pass	Fail																											
Subject No.1	_____	_____	_____																											
Subject No.2	_____	_____	_____																											
Subject No.3	_____	_____	_____																											
Subject No.4	_____	_____	_____																											
Subject No.5	_____	_____	_____																											
Subject No.6	_____	_____	_____																											
<b>2.4.13 Water ingress and jump test</b>		<b>Regulations: MSC.81(70) 1/3.1.9</b>																												
Test Procedure	Acceptance Criteria	Significant Test Data																												
<p>The test subjects should pre-wet their Anti-Exposure suit and then be weighed. Following a jump into the water from a height sufficient to totally immerse the body, each test subject should be weighed again.</p> <p>Weighing should be performed on a machine accurate to <math>\pm 100</math>g.</p>	<p>The difference in the combined mass of the test subject and the suit should not exceed 500 g.</p>	<p>Mass difference <math>\leq 500</math>g</p> <table style="width:100%; border-collapse: collapse;"> <thead> <tr> <th style="width:60%;"></th> <th style="width:20%;">Pass</th> <th style="width:20%;">Fail</th> </tr> </thead> <tbody> <tr> <td>Subject No.1</td> <td>_____</td> <td>_____</td> </tr> <tr> <td>Subject No.2</td> <td>_____</td> <td>_____</td> </tr> <tr> <td>Subject No.3</td> <td>_____</td> <td>_____</td> </tr> <tr> <td>Subject No.4</td> <td>_____</td> <td>_____</td> </tr> <tr> <td>Subject No.5</td> <td>_____</td> <td>_____</td> </tr> <tr> <td>Subject No.6</td> <td>_____</td> <td>_____</td> </tr> </tbody> </table> <p>Comments/Observations</p>		Pass	Fail	Subject No.1	_____	_____	Subject No.2	_____	_____	Subject No.3	_____	_____	Subject No.4	_____	_____	Subject No.5	_____	_____	Subject No.6	_____	_____							
	Pass	Fail																												
Subject No.1	_____	_____																												
Subject No.2	_____	_____																												
Subject No.3	_____	_____																												
Subject No.4	_____	_____																												
Subject No.5	_____	_____																												
Subject No.6	_____	_____																												

<b>Anti-exposure suits</b>	Manufacturer: _____ Model: _____ Lot/Serial Number: _____	Date: _____ Time: _____ Surveyor: _____ Organization: _____																								
<b>2.4.14 Jump test</b>		<b>Regulations: LSA Code II/2.4.1.1.2; MSC.81(70) 1/3.1.10</b>																								
Test Procedure	Acceptance Criteria	Significant Test Data																								
The test subjects should jump with the Anti-Exposure suit and lifejacket if required from a height of 4.5m vertically into the water. After the jump, the anti-exposure suit and its attachments should be examined for damage or dislodging, and the test subject should be questioned concerning whether the suit caused any injury to the wearer.	The Anti - Exposure suit and its attachments should not be damaged or dislodged in any way.  The test subject should not be injured by the suit.  The light, if fitted, should not injure the test subject.	<table style="width:100%; border:none;"> <tr> <td></td> <td style="text-align:center">Pass</td> <td style="text-align:center">Fail</td> </tr> <tr> <td>Subject No.1</td> <td style="text-align:center">_____</td> <td style="text-align:center">_____</td> </tr> <tr> <td>Subject No.2</td> <td style="text-align:center">_____</td> <td style="text-align:center">_____</td> </tr> <tr> <td>Subject No.3</td> <td style="text-align:center">_____</td> <td style="text-align:center">_____</td> </tr> <tr> <td>Subject No.4</td> <td style="text-align:center">_____</td> <td style="text-align:center">_____</td> </tr> <tr> <td>Subject No.5</td> <td style="text-align:center">_____</td> <td style="text-align:center">_____</td> </tr> <tr> <td>Subject No.6</td> <td style="text-align:center">_____</td> <td style="text-align:center">_____</td> </tr> <tr> <td colspan="3">Comments/Observations</td> </tr> </table>		Pass	Fail	Subject No.1	_____	_____	Subject No.2	_____	_____	Subject No.3	_____	_____	Subject No.4	_____	_____	Subject No.5	_____	_____	Subject No.6	_____	_____	Comments/Observations		
	Pass	Fail																								
Subject No.1	_____	_____																								
Subject No.2	_____	_____																								
Subject No.3	_____	_____																								
Subject No.4	_____	_____																								
Subject No.5	_____	_____																								
Subject No.6	_____	_____																								
Comments/Observations																										
<b>2.4.15 Leak test</b>		<b>Regulations: LSA Code II/2.4.1.1; MSC.81(70) 1/3.1.11</b>																								
Test Procedure	Acceptance Criteria	Significant Test Data																								
The test subject should pre-wet the anti-exposure suit and be weighed. The test subject should then be instructed to do one of the following:  .1 a period of flotation in calm water of 1h; or  .2 swimming for 20 min for a distance of at least 200 m  The test subject should be weighed again after the task.  The weighing machine should be accurate to ± 100g.	The ingress of water into the pre-wetted suit should not exceed a mass of 200g.	<p>Indicate which alternative is used. <input type="checkbox"/>Alternative 1 <input type="checkbox"/>Alternative 2</p> <p>Water ingress ≤ 200g</p> <table style="width:100%; border:none;"> <tr> <td></td> <td style="text-align:center">Pass</td> <td style="text-align:center">Fail</td> </tr> <tr> <td>Subject No.1</td> <td style="text-align:center">_____</td> <td style="text-align:center">_____</td> </tr> <tr> <td>Subject No.2</td> <td style="text-align:center">_____</td> <td style="text-align:center">_____</td> </tr> <tr> <td>Subject No.3</td> <td style="text-align:center">_____</td> <td style="text-align:center">_____</td> </tr> <tr> <td>Subject No.4</td> <td style="text-align:center">_____</td> <td style="text-align:center">_____</td> </tr> <tr> <td>Subject No.5</td> <td style="text-align:center">_____</td> <td style="text-align:center">_____</td> </tr> <tr> <td>Subject No.6</td> <td style="text-align:center">_____</td> <td style="text-align:center">_____</td> </tr> <tr> <td colspan="3">Comments/Observations</td> </tr> </table>		Pass	Fail	Subject No.1	_____	_____	Subject No.2	_____	_____	Subject No.3	_____	_____	Subject No.4	_____	_____	Subject No.5	_____	_____	Subject No.6	_____	_____	Comments/Observations		
	Pass	Fail																								
Subject No.1	_____	_____																								
Subject No.2	_____	_____																								
Subject No.3	_____	_____																								
Subject No.4	_____	_____																								
Subject No.5	_____	_____																								
Subject No.6	_____	_____																								
Comments/Observations																										

<b>Anti-exposure suits</b>	Manufacturer: _____ Model: _____ Lot/Serial Number: _____	Date: _____ Time: _____ Surveyor: _____ Organization: _____																																										
<b>2.4.16 Swimming and water emergent test</b>		<b>Regulations: LSA Code II/2.4.1.2.3 MSC.81(70) 1/3.1.12</b>																																										
Test Procedure	Acceptance Criteria	Significant Test Data																																										
<p>All test subjects, each wearing a lifejacket but not the anti-exposure suit, should attempt to swim 25 m and board a liferaft or rigid platform with its surface 300 mm above the water surface.</p> <p>Test subjects who successfully complete this task should also perform it wearing the anti-exposure suit.</p> <p>If designed to be used with a lifejacket, then anti-exposure suit should be tested with the subject also wearing a lifejacket.</p>	<p>All qualified test subjects should be able to board the liferaft or platform while wearing the anti-exposure suit.</p>	<p>1) 25m swim and boarding without lifejacket.</p> <table style="width:100%; margin-left: 40px;"> <thead> <tr> <th></th> <th style="text-align:center;">Pass</th> <th style="text-align:center;">Fail</th> </tr> </thead> <tbody> <tr><td>Subject No.1</td><td style="text-align:center;">_____</td><td style="text-align:center;">_____</td></tr> <tr><td>Subject No.2</td><td style="text-align:center;">_____</td><td style="text-align:center;">_____</td></tr> <tr><td>Subject No.3</td><td style="text-align:center;">_____</td><td style="text-align:center;">_____</td></tr> <tr><td>Subject No.4</td><td style="text-align:center;">_____</td><td style="text-align:center;">_____</td></tr> <tr><td>Subject No.5</td><td style="text-align:center;">_____</td><td style="text-align:center;">_____</td></tr> <tr><td>Subject No.6</td><td style="text-align:center;">_____</td><td style="text-align:center;">_____</td></tr> </tbody> </table> <p>2) 25 m swim and boarding with immersion suit</p> <table style="width:100%; margin-left: 40px;"> <thead> <tr> <th></th> <th style="text-align:center;">Pass</th> <th style="text-align:center;">Fail</th> </tr> </thead> <tbody> <tr><td>Subject No.1</td><td style="text-align:center;">_____</td><td style="text-align:center;">_____</td></tr> <tr><td>Subject No.2</td><td style="text-align:center;">_____</td><td style="text-align:center;">_____</td></tr> <tr><td>Subject No.3</td><td style="text-align:center;">_____</td><td style="text-align:center;">_____</td></tr> <tr><td>Subject No.4</td><td style="text-align:center;">_____</td><td style="text-align:center;">_____</td></tr> <tr><td>Subject No.5</td><td style="text-align:center;">_____</td><td style="text-align:center;">_____</td></tr> <tr><td>Subject No.6</td><td style="text-align:center;">_____</td><td style="text-align:center;">_____</td></tr> </tbody> </table> <p>Comments/Observations</p>		Pass	Fail	Subject No.1	_____	_____	Subject No.2	_____	_____	Subject No.3	_____	_____	Subject No.4	_____	_____	Subject No.5	_____	_____	Subject No.6	_____	_____		Pass	Fail	Subject No.1	_____	_____	Subject No.2	_____	_____	Subject No.3	_____	_____	Subject No.4	_____	_____	Subject No.5	_____	_____	Subject No.6	_____	_____
	Pass	Fail																																										
Subject No.1	_____	_____																																										
Subject No.2	_____	_____																																										
Subject No.3	_____	_____																																										
Subject No.4	_____	_____																																										
Subject No.5	_____	_____																																										
Subject No.6	_____	_____																																										
	Pass	Fail																																										
Subject No.1	_____	_____																																										
Subject No.2	_____	_____																																										
Subject No.3	_____	_____																																										
Subject No.4	_____	_____																																										
Subject No.5	_____	_____																																										
Subject No.6	_____	_____																																										

<b>Anti-exposure suits</b>	Manufacturer: _____ Model: _____ Lot/Serial Number: _____	Date: _____ Time: _____ Surveyor: _____ Organization: _____																					
<b>2.4.17 Oil resistance test</b>		<b>Regulations: LSA Code; MSC.81(70) 1/3.1.13</b>																					
Test Procedure	Acceptance Criteria	Significant Test Data																					
<p>After all its apertures have been sealed an anti-exposure suit should be immersed for a period of 24 h under 100 mm head of diesel oil at normal room temperature.</p> <p>The surface oil should then be wiped off and the suit subjected to the test prescribed in 2.4.15.</p>	<p>The ingress of water should not exceed a mass of 200g.</p>	<p>Indicate which alternative is used.  <input type="checkbox"/>Alternative 1 <input type="checkbox"/>Alternative 2</p> <p>Water ingress ≤ 200g</p> <table style="width:100%; border: none;"> <tr> <td></td> <td style="text-align: center;">Pass</td> <td style="text-align: center;">Fail</td> </tr> <tr> <td>Subject No.1</td> <td style="text-align: center;">_____</td> <td style="text-align: center;">_____</td> </tr> <tr> <td>Subject No.2</td> <td style="text-align: center;">_____</td> <td style="text-align: center;">_____</td> </tr> <tr> <td>Subject No.3</td> <td style="text-align: center;">_____</td> <td style="text-align: center;">_____</td> </tr> <tr> <td>Subject No.4</td> <td style="text-align: center;">_____</td> <td style="text-align: center;">_____</td> </tr> <tr> <td>Subject No.5</td> <td style="text-align: center;">_____</td> <td style="text-align: center;">_____</td> </tr> <tr> <td>Subject No.6</td> <td style="text-align: center;">_____</td> <td style="text-align: center;">_____</td> </tr> </table> <p>Comments/Observations</p>		Pass	Fail	Subject No.1	_____	_____	Subject No.2	_____	_____	Subject No.3	_____	_____	Subject No.4	_____	_____	Subject No.5	_____	_____	Subject No.6	_____	_____
	Pass	Fail																					
Subject No.1	_____	_____																					
Subject No.2	_____	_____																					
Subject No.3	_____	_____																					
Subject No.4	_____	_____																					
Subject No.5	_____	_____																					
Subject No.6	_____	_____																					



<b>Anti-exposure suits</b>	Manufacturer: _____ Model: _____ Lot/Serial Number: _____	Date: _____ Time: _____ Surveyor: _____ Organization: _____
<b>2.4.19 Fire test</b>		<b>Regulations: LSA Code II/2.4.1.1.5; MSC.81(70) 1/3.1.15</b>
Test Procedure	Acceptance Criteria	Significant Test Data
<p>A test pan 30 cm x 35 cm x 6 cm should be placed in an essentially draught-free area. Water should be put in the bottom of the test pan to make a minimum total depth of 1 cm followed by enough petrol to make a minimum depth of 4 cm. The petrol should then be ignited and allowed to burn freely for 30 s. If necessary the anti-exposure suit should be draped over a hanger to ensure the whole of the suit is enveloped in the flames , with the bottom of the suit 25 cm above the top edge of the test pan so that the duration of exposure to the flames is 2 s.</p>	<p>The anti-exposure suit should not sustain burning for more than 6 s or continue melting after being removed from the flames.</p>	<p>Did the anti-exposure suit continue to burn for more than 6 s or continue melting after being removed from the flames?</p> <p style="text-align: center;"><input type="checkbox"/> YES   <input type="checkbox"/> NO</p> <p>Comments/Observations</p>

<b>Anti-exposure suits</b>	Manufacturer: _____ Model: _____ Lot/Serial Number: _____	Date: _____ Time: _____ Surveyor: _____ Organization: _____
<b>2.4.20 Temperature cycling test</b>		<b>Regulations: LSA Code I/1.2.2.2; MSC.81(70) 1/3.1.16</b>
Test Procedure	Acceptance Criteria	Significant Test Data
<p>The following test should be carried out on two immersion suits</p> <p>The anti-exposure suits should be alternately subjected to surrounding temperatures of -30°C and +65°C. These alternating cycles need not follow immediately after each other and the following procedure, repeated for a total of 10 cycles, is acceptable:</p> <p>.1 an 8 h exposure at a minimum temperature of +65°C to be completed in one day; and</p> <p>.2 the specimens removed from the warm chamber that same day and left exposed under ordinary room conditions at a temperature of 20°C ± 3°C until the next day;</p> <p>.3 an 8 h exposure at a maximum temperature of -30°C to be completed the next day; and</p> <p>.4 the specimens removed from the cold chamber that same day and left exposed under ordinary room conditions at a temperature of 20°C</p>	<p>The anti-exposure suit's should show no signs of damage such as shrinking, swelling dissolution or changes of mechanical qualities.</p>	<p>(See following page for test data)</p> <p>Passed _____ Failed _____</p> <p>Comments/Observations</p>

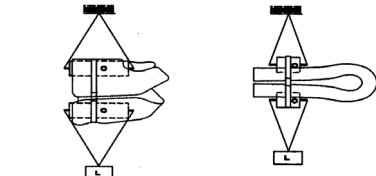

± 3°C until the next day.				
<b>Anti-exposure suits</b>	Manufacturer: _____ Model: _____ Lot/Serial Number: _____	Date: _____ Time: _____ Surveyor: _____ Organization: _____		
<b>2.4.21 Temperature cycling test – Test Data</b>		<b>Regulations: LSA Code I/1.2.1; MSC.81(70) 1/3.1.16</b>		
	<i><b>HOT CYCLE</b></i>		<i><b>COLD CYCLE</b></i>	
Cycle 1	Date In: _____ Time In: _____ Temperature: _____ °C	Date Out: _____ Time Out: _____ Duration: _____ hours	Date In: _____ Time In: _____ Temperature: _____ °C	Date Out: _____ Time Out: _____ Duration: _____ hours
Cycle 2	Date In: _____ Time In: _____ Temperature: _____ °C	Date Out: _____ Time Out: _____ Duration: _____ hours	Date In: _____ Time In: _____ Temperature: _____ °C	Date Out: _____ Time Out: _____ Duration: _____ hours
Cycle 3	Date In: _____ Time In: _____ Temperature: _____ °C	Date Out: _____ Time Out: _____ Duration: _____ hours	Date In: _____ Time In: _____ Temperature: _____ °C	Date Out: _____ Time Out: _____ Duration: _____ hours
Cycle 4	Date In: _____ Time In: _____ Temperature: _____ °C	Date Out: _____ Time Out: _____ Duration: _____ hours	Date In: _____ Time In: _____ Temperature: _____ °C	Date Out: _____ Time Out: _____ Duration: _____ hours
Cycle 5	Date In: _____ Time In: _____ Temperature: _____ °C	Date Out: _____ Time Out: _____ Duration: _____ hours	Date In: _____ Time In: _____ Temperature: _____ °C	Date Out: _____ Time Out: _____ Duration: _____ hours
Cycle 6	Date In: _____ Time In: _____ Temperature: _____ °C	Date Out: _____ Time Out: _____ Duration: _____ hours	Date In: _____ Time In: _____ Temperature: _____ °C	Date Out: _____ Time Out: _____ Duration: _____ hours
Cycle 7	Date In: _____ Time In: _____ Temperature: _____ °C	Date Out: _____ Time Out: _____ Duration: _____ hours	Date In: _____ Time In: _____ Temperature: _____ °C	Date Out: _____ Time Out: _____ Duration: _____ hours
Cycle 8	Date In: _____ Time In: _____ Temperature: _____ °C	Date Out: _____ Time Out: _____ Duration: _____ hours	Date In: _____ Time In: _____ Temperature: _____ °C	Date Out: _____ Time Out: _____ Duration: _____ hours
Cycle 9	Date In: _____ Time In: _____ Temperature: _____ °C	Date Out: _____ Time Out: _____ Duration: _____ hours	Date In: _____ Time In: _____ Temperature: _____ °C	Date Out: _____ Time Out: _____ Duration: _____ hours
	Date In: _____	Date Out: _____	Date In: _____	Date Out: _____

Cycle 10	Time In: _____ Temperature: _____ °C	Time Out: _____ Duration: _____ hours	Time In: _____ Temperature: _____ °C	Time Out: _____ Duration: _____ hours
<b>Anti-exposure suits</b>	Manufacturer: _____ Model: _____ Lot/Serial Number: _____	Date: _____ Surveyor: _____ Organization: _____	Time: _____	
<b>2.4.22 Buoyancy test</b>		<b>Regulations: LSA Code II/2.4.1.1.1; MSC.81(70) 1/3.1.17</b>		
Test Procedure	Acceptance Criteria	Significant Test Data		
The Anti-exposure suit should have inherent buoyancy of at least 70 N  The buoyancy of an anti-exposure suit designed to be worn without a lifejacket should be measured before and after 24 h complete submersion to just below the surface in fresh water.	The difference between the initial buoyancy and the final buoyancy should not exceed 5% of the initial buoyancy.	Buoyancy 1 _____ kg	Buoyancy 2 _____ kg	%difference _____ %
		Passed _____	Failed _____	
		Comments/Observations		
<b>2.4.23 Strength test</b>		<b>Regulations: LSA Code II; MSC.81(70) 1/3.1.18</b>		
Test Procedure	Acceptance Criteria	Significant Test Data		
The anti-exposure suit should be immersed in water for a period of 2 min. It should then be removed from the water and closed in the same manner as when worn by a person. A force of not less than 3200 N should be applied to the lifting loop and a force of not less than 1350 N should be applied to the parts other than the lifting loop for 30 min.  The anti-exposure suit may be cut if necessary to accommodate the test device.	The anti-exposure suit should not be damaged as a result of this test.   Vest-type lifejacket      Yoke or over-the-head type lifejacket	Passed _____ Failed _____		
		Comments/Observations		

<b>Anti-exposure suits</b>	Manufacturer: _____ Model: _____ Lot/Serial Number: _____	Date: _____ Time: _____ Surveyor: _____ Organization: _____
<b>2.4.24 Thermal protective test (General)</b>		<b>Regulations: LSA Code II/2.4.2; MSC.81(70) 1/3.2.1 – 3.2.5</b>
Test Procedure	Acceptance Criteria	Significant Test Data
<p>The thermal protective qualities may be measured using a thermal manikin, when such a method is required by an Administration and has been demonstrated to provide test results which correlate satisfactorily in all aspects to test results using human subjects.</p> <p>If human subjects are used, they should be medically examined before being accepted for the tests. Each design of immersion suit is to be tested by test subjects specified in 2.4.5</p> <p>Where human subjects are used, the tests should always be conducted under the supervision of physician. Emergency resuscitation equipment should be available during all tests. For safety reasons, ECG should be monitored during every test. Testing should be stopped at the wish of the test subjects, if the falling rate of the core temperature is more than 1.5° C per hour after the first half hour. or if the skin temperature of hand, foot or lumbar region should fall below 10° C, or if the attending physician considers it advisable.</p> <p>When testing with human subjects, continuous body core temperature (rectal temperature) and skin temperature of lumbar region, both hands, calves, foot (foot instep) and heels, should be measured. The accuracy of the measuring system should be +/- 0.2°C. Appropriate corresponding measurements should be taken if a manikin is used in lieu of human subjects.</p> <p>Prior to tests, the same amount of water resulting from the jump test in paragraph 2.4.15 should be poured into the dry suit worn over the dry test clothing specified in 2.4.7 by the test subject lying down.</p>		Comments/Observations

<b>Anti-exposure suits</b>	Manufacturer: _____ Model: _____ Lot/Serial Number: _____	Date: _____ Time: _____ Surveyor: _____ Organization: _____																												
<b>2.4.25 Thermal Protective test (Continued)</b>		<b>Regulations: LSA Code II/2.4.2; MSC.81(70) 1/3.2.13, 3.2.14</b>																												
Test Procedure	Acceptance Criteria	Significant Test Data																												
<p>Each test subject should wear an anti-exposure suit previously subjected to the water ingress and jump test in paragraph 2.4.13. Following a 1 h period of immersion, with hands gloved and hood donned, in circulating calm water at + 5°C, each test subject's body core temperature should not fall more than 2°C below the normal level of the subject's temperature.</p> <p>Immediately on leaving the water after completion of the test prescribed in 2.4.24 each test subject should be able to pick up a pencil as specified in paragraph 2.4.9 and write.</p> <p>The anti-exposure suit should be so constructed, that when worn as marked, the suit continues to provide sufficient thermal protection following one jump into the water which totally submerges the test subject and should ensure that when it is worn in calm water at a temperature of 5°C, the test subject's body core temperature does not fall at a rate of more than 1.5°C per hour, after the first 0.5 h.</p>	<p>Same mass of water which was the result from test 2.4.15, should be poured into the immersion suit.</p> <p>See attached test sheets for temperatures during the immersion tests:</p> <p>Comments/Observations</p>	<p>Same mass of water which was the result from test 2.4.15, should be poured into the immersion suit</p> <table style="width:100%; border-collapse: collapse;"> <thead> <tr> <th style="width:50%;"></th> <th style="width:15%; text-align:center;">Beginning of test</th> <th style="width:15%; text-align:center;">End of test</th> <th style="width:20%; text-align:center;">Normal temperature</th> </tr> </thead> <tbody> <tr> <td>Subject No 1</td> <td style="text-align:center;">_____</td> <td style="text-align:center;">_____</td> <td style="text-align:center;">_____</td> </tr> <tr> <td>Subject No.2</td> <td style="text-align:center;">_____</td> <td style="text-align:center;">_____</td> <td style="text-align:center;">_____</td> </tr> <tr> <td>Subject No.3</td> <td style="text-align:center;">_____</td> <td style="text-align:center;">_____</td> <td style="text-align:center;">_____</td> </tr> <tr> <td>Subject No.4</td> <td style="text-align:center;">_____</td> <td style="text-align:center;">_____</td> <td style="text-align:center;">_____</td> </tr> <tr> <td>Subject No.5</td> <td style="text-align:center;">_____</td> <td style="text-align:center;">_____</td> <td style="text-align:center;">_____</td> </tr> <tr> <td>Subject No.6</td> <td style="text-align:center;">_____</td> <td style="text-align:center;">_____</td> <td style="text-align:center;">_____</td> </tr> </tbody> </table> <p>Passed _____ Failed _____</p> <p>Pick up a pencil and write after 1 h period of immersion:</p> <p>Subject No 1 <input type="checkbox"/>YES <input type="checkbox"/>NO</p> <p>Subject No 2 <input type="checkbox"/>YES <input type="checkbox"/>NO</p> <p>Subject No 3 <input type="checkbox"/>YES <input type="checkbox"/>NO</p> <p>Subject No 4 <input type="checkbox"/>YES <input type="checkbox"/>NO</p> <p>Subject No 5 <input type="checkbox"/>YES <input type="checkbox"/>NO</p> <p>Subject No 6 <input type="checkbox"/>YES <input type="checkbox"/>NO</p> <p>Passed _____ Failed _____</p> <p>Pick up a pencil and write after 6 h period of immersion:</p> <p>Subject No 1 <input type="checkbox"/>YES <input type="checkbox"/>NO</p> <p>Subject No 2 <input type="checkbox"/>YES <input type="checkbox"/>NO</p> <p>Subject No 3 <input type="checkbox"/>YES <input type="checkbox"/>NO</p> <p>Subject No 4 <input type="checkbox"/>YES <input type="checkbox"/>NO</p> <p>Subject No 5 <input type="checkbox"/>YES <input type="checkbox"/>NO</p> <p>Subject No 6 <input type="checkbox"/>YES <input type="checkbox"/>NO</p>		Beginning of test	End of test	Normal temperature	Subject No 1	_____	_____	_____	Subject No.2	_____	_____	_____	Subject No.3	_____	_____	_____	Subject No.4	_____	_____	_____	Subject No.5	_____	_____	_____	Subject No.6	_____	_____	_____
	Beginning of test	End of test	Normal temperature																											
Subject No 1	_____	_____	_____																											
Subject No.2	_____	_____	_____																											
Subject No.3	_____	_____	_____																											
Subject No.4	_____	_____	_____																											
Subject No.5	_____	_____	_____																											
Subject No.6	_____	_____	_____																											

2.4.25 Thermal Protective test (Continued)	Regulations: LSA Code II/2.4.2; MSC.81(70) 1/3.2.13, 3.2.14	
Test Procedure	Acceptance Criteria	Significant Test Data
		Passed _____ Failed _____  See attached test sheets for temperatures during the immersion tests:  Comments/Observations

<b>Anti-exposure suits</b>		Manufacturer: _____ Model: _____ Lot/Serial Number: _____		Date: _____ Time: _____ Surveyor: _____ Organization: _____	
<b>2.4.26 Test sheets for temperatures during immersion tests</b>			<b>Regulations: LSA Code II/2.4.2.1.2; MSC.81(70) 1/3.2.13 &amp; 3.2.14</b>		
<b>SUBJECT 1</b>	<b>SUBJECT 2</b>	<b>SUBJECT 3</b>	<b>SUBJECT 4</b>	<b>SUBJECT 5</b>	<b>SUBJECT 6</b>
Rectal temp after 1 hr:___	Rectal temp after 1 hr:___	Rectal temp after 1 hr:___	Rectal temp after 1 hr:___	Rectal temp after 1 hr:___	Rectal temp after 1 hr:___
Skin temp at lumbar region after 1 hr : _____	Skin temp at lumbar region after 1 hr : _____	Skin temp at lumbar region after 1 hr : _____	Skin temp at lumbar region after 1 hr : _____	Skin temp at lumbar region after 1 hr : _____	Skin temp at lumbar region after 1 hr : _____
Skin temp at left hand after 1 hr:_____	Skin temp at left hand after 1 hr:_____	Skin temp at left hand after 1 hr:_____	Skin temp at left hand after 1 hr:_____	Skin temp at left hand after 1 hr:_____	Skin temp at left hand after 1 hr:_____
Skin temp at right hand after 1 hr:_____	Skin temp at right hand after 1 hr:_____	Skin temp at right hand after 1 hr:_____	Skin temp at right hand after 1 hr:_____	Skin temp at right hand after 1 hr:_____	Skin temp at right hand after 1 hr:_____
Skin temp at calves after 1 hr:_____	Skin temp at calves after 1 hr:_____	Skin temp at calves after 1 hr:_____	Skin temp at calves after 1 hr:_____	Skin temp at calves after 1 hr:_____	Skin temp at calves after 1 hr:_____
Skin temp at left foot (foot instep) after 1 hr:___	Skin temp at left foot (foot instep) after 1 hr:___	Skin temp at left foot (foot instep) after 1 hr:___	Skin temp at left foot (foot instep) after 1 hr:___	Skin temp at left foot (foot instep) after 1 hr:___	Skin temp at left foot (foot instep) after 1 hr:___
Skin temp at right foot (foot instep) after 1 hr:___	Skin temp at right foot (foot instep) after 1 hr:___	Skin temp at right foot (foot instep) after 1 hr:___	Skin temp at right foot (foot instep) after 1 hr:___	Skin temp at right foot (foot instep) after 1 hr:___	Skin temp at right foot (foot instep) after 1 hr:___
Skin temp at left heel after 1 hr:_____	Skin temp at left heel after 1 hr:_____	Skin temp at left heel after 1 hr:_____	Skin temp at left heel after 1 hr:_____	Skin temp at left heel after 1 hr:_____	Skin temp at left heel after 1 hr:_____
Did the wearer's body core temperature fall at a rate more than 1,5°C per hour, after the first 0,5 h? <input type="checkbox"/> Yes <input type="checkbox"/> No	Did the wearer's body core temperature fall at a rate more than 1,5°C per hour, after the first 0,5 h? <input type="checkbox"/> Yes <input type="checkbox"/> No	Did the wearer's body core temperature fall at a rate more than 1,5°C per hour, after the first 0,5 h? <input type="checkbox"/> Yes <input type="checkbox"/> No	Did the wearer's body core temperature fall at a rate more than 1,5°C per hour, after the first 0,5 h? <input type="checkbox"/> Yes <input type="checkbox"/> No	Did the wearer's body core temperature fall at a rate more than 1,5°C per hour, after the first 0,5 h? <input type="checkbox"/> Yes <input type="checkbox"/> No	Did the wearer's body core temperature fall at a rate more than 1,5°C per hour, after the first 0,5 h? <input type="checkbox"/> Yes <input type="checkbox"/> No

## **2.5 THERMAL PROTECTIVE AIDS**

### **EVALUATION AND TEST REPORT**

- 2.5.1 General data and specifications
- 2.5.2 Submitted drawings, reports and documents
- 2.5.3 Quality assurance
- 2.5.4 Visual inspection
- 2.5.5 Fabric test – Water resistance
- 2.5.6 Fabric test – Thermal conductance
- 2.5.7 Temperature cycling test
- 2.5.8 Test subjects
- 2.5.9 Test clothing
- 2.5.10 Donning test 1
- 2.5.11 Donning test 2 at low temperature
- 2.5.12 Discarding test
- 2.5.13 Oil resistance test

**2.5 THERMAL PROTECTIVE AIDS  
EVALUATION AND TEST REPORT**

<b>Manufacturer</b>	
<b>Type</b>	
<b>Date</b>	
<b>Place</b>	
<b>Name Surveyor printed</b>	
<b>Signature</b>	
<b>Approving Organization</b>	



<b>Thermal protective aids</b>	Manufacturer: _____ Model: _____ Lot/Serial Number: _____	Date: _____ Time: _____ Surveyor: _____ Organization: _____
<b>2.5.1 General data and specifications</b>		<b>Regulations: LSA Code II/2.5; MSC.81(70) 1/ 3.3</b>
General Information		
<b>Construction Material:</b>  Fabric manufactured by: _____  Type: _____  Is the TPA of highly visible colour?		<b>Donning instructions:</b>  <input type="checkbox"/> YES <input type="checkbox"/> NO    <input type="checkbox"/> YES <input type="checkbox"/> NO

<b>Thermal protective aids</b>		Manufacturer: _____ Model: _____ Lot/Serial Number: _____	Date: _____ Time: _____ Surveyor: _____ Organization: _____
<b>2.5.2 Submitted drawings, reports and documents</b>			
<b>Submitted drawings and documents</b>			<b>Status</b>
<b>Drawing No.</b>	<b>Revision No. &amp; date</b>	<b>Title of drawing</b>	
<b>Submitted reports and documents</b>			<b>Status</b>
<b>Report/Document No.</b>	<b>Revision No. &amp; date</b>	<b>Title of report / document</b>	
		Maintenance Manual -	
		Operations Manual -	

<b>Thermal protective aids</b>	Manufacturer: _____ Model: _____ Lot/Serial Number: _____	Date: _____ Time: _____ Surveyor: _____ Organization: _____
<b>2.5.3 Quality Assurance</b>		<b>Regulations: - MSC.81(70) 2/1.1, 1.2</b>
<p>Except where all appliances of a particular type are required by Chapter III of the International Convention for the Safety of Life at Sea, 1974, as amended, of the international Life-Saving Appliances (LSA) Code, to be inspected, representatives of the Administration should make random inspections of manufacturers to ensure that the quality of life-saving appliances and materials used comply with the specification of the approved prototype life-saving appliance.</p> <p>Manufacturers should be required to institute a quality control procedure to ensure that life-saving appliances are produced to the same standard as the prototype life-saving appliance approved by the Administration and to keep records of any production tests carried out in accordance with the Administration's instructions.</p>		<p>Quality Assurance Standard Used: -</p> <p>Quality Assurance Procedure: -</p> <p>Quality Assurance Manual: -</p> <p>Description of System.</p> <p>Quality Assurance System acceptable: Yes/No</p> <p>Comments/Observations</p>

<b>Thermal protective aids</b>	Manufacturer: _____ Model: _____ Lot/Serial Number: _____	Date: _____ Time: _____ Surveyor: _____ Organization: _____
<b>2.5.4 Visual Inspection</b>		<b>Regulations: LSA Code I/1.2.2, II/2.5; MSC. 81(70);</b>
Test Procedure	Acceptance Criteria	Significant Test Data
<p>Is the thermal protection aid of high visible colour?</p> <p>Does the thermal protection aid cover the whole body of the wearer with the exception of the face?</p> <p>If provided with arms, are the hand covered, or are permanently attached gloves provided?</p> <p>Be clearly marked with approval information including the Administration which approved it, date of manufacture and any operational restrictions. Be provided with labels giving servicing details and intervals between servicing, operating instructions, general information and manufacturer's details.</p>	<p>Be of an international or vivid reddish orange, or a comparably high visible colour on all parts where this will assist detection at sea.</p> <p>Cover the whole body of persons of all sizes wearing a lifejacket with the exception of the face.</p>	<p><input type="checkbox"/>Yes    <input type="checkbox"/>No</p> <p><input type="checkbox"/>Yes    <input type="checkbox"/>No</p> <p><input type="checkbox"/>Yes    <input type="checkbox"/>No</p>

<b>Thermal protective aids</b>	Manufacturer: _____	Date: _____ Time: _____
	Model: _____	Surveyor: _____
	Lot/Serial Number: _____	Organization: _____
<b>2.5.5 Fabric Test - Water resistance</b>		<b>Regulations: LSA Code ; MSC.81(70) 1/3.3.1</b>
<b>Test Procedure</b>	<b>Acceptance Criteria</b>	<b>Significant Test Data</b>
The fabric from which the thermal protective aid is constructed should be tested to determine its resistance to penetration by a 2m head of water.	The fabric should maintain its watertight integrity when supporting a column of water 2 m high.	Does the material support a column of water of 2 m high  <input type="checkbox"/> YES <input type="checkbox"/> NO  Test method used: _____  Comments/Observations
<b>2.5.6 Fabric test - Thermal conductance</b>		<b>Regulations: LSA Code II/2.5.1; MSC.81(70) 1/3.3.2</b>
<b>Test Procedure</b>	<b>Acceptance Criteria</b>	<b>Significant Test Data</b>
The thermal conductance of the fabric of which the thermal protective aid is manufactured should be measured.	The fabric should have a thermal conductance of not more than 7800 W/m <sup>2</sup> K and shall be so constructed that, when used to enclose a person, it shall reduce both the convective and evaporative heat loss from the wearer's body.	Passed _____ Failed _____  All data is to be attached here.  Comments/Observations

<b>Thermal protective aids</b>	Manufacturer: _____ Model: _____ Lot/Serial Number: _____	Date: _____ Time: _____ Surveyor: _____ Organization: _____
<b>2.5.7 Temperature cycling test</b>		<b>Regulations: LSA Code II/1.2.2.2; MSC.81(70) 1/3.3.3</b>
Test Procedure	Acceptance Criteria	Significant Test Data
<p>A thermal protective aid should be subjected to surrounding temperatures of -30°C and +65°C. These alternating cycles need not follow immediately after each other and the following procedure, repeated for a total of 10 cycles, is acceptable:</p> <p>.1 an 8 h exposure at a minimum temperature of +65°C to be completed in one day; and</p> <p>.2 the specimens removed from the warm chamber that same day and left exposed under ordinary room conditions at a temperature of 20°C ± 3°C until the next day;</p> <p>.3 an 8 h exposure at a maximum temperature of -30°C to be completed the next day; and</p> <p>.4 the specimen removed from the cold chamber that same day and left exposed under ordinary room conditions at a temperature of 20°C ± 3°C until the next day;</p>	<p>The thermal protective aid should show no signs of damage such as shrinking, swelling dissolution or changes of mechanical qualities</p>	<p>See following page for test data.</p> <p>Passed _____ Failed _____</p> <p>Comments/Observations</p>

<b>Thermal protective aids</b>	Manufacturer: _____ Model: _____ Lot/Serial Number: _____	Date: _____ Time: _____ Surveyor: _____ Organization: _____
<b>2.5.7 Temperature cycling test – Test data</b>		<b>Regulations: LSA Code I/1.2.2.2; MSC.81(70) 1/3.3.3</b>
	<b>HOT CYCLE</b>	<b>COLD CYCLE</b>
Cycle 1	Date In: _____ Time In: _____ Temperature: _____ °C Duration: _____ hours	Date In: _____ Time In: _____ Temperature: _____ °C Duration: _____ hours
Cycle 2	Date In: _____ Time In: _____ Temperature: _____ °C Duration: _____ hours	Date In: _____ Time In: _____ Temperature: _____ °C Duration: _____ hours
Cycle 3	Date In: _____ Time In: _____ Temperature: _____ °C Duration: _____ hours	Date In: _____ Time In: _____ Temperature: _____ °C Duration: _____ hours
Cycle 4	Date In: _____ Time In: _____ Temperature: _____ °C Duration: _____ hours	Date In: _____ Time In: _____ Temperature: _____ °C Duration: _____ hours
Cycle 5	Date In: _____ Time In: _____ Temperature: _____ °C Duration: _____ hours	Date In: _____ Time In: _____ Temperature: _____ °C Duration: _____ hours
Cycle 6	Date In: _____ Time In: _____ Temperature: _____ °C Duration: _____ hours	Date In: _____ Time In: _____ Temperature: _____ °C Duration: _____ hours
Cycle 7	Date In: _____ Time In: _____ Temperature: _____ °C Duration: _____ hours	Date In: _____ Time In: _____ Temperature: _____ °C Duration: _____ hours
Cycle 8	Date In: _____ Time In: _____ Temperature: _____ °C Duration: _____ hours	Date In: _____ Time In: _____ Temperature: _____ °C Duration: _____ hours
Cycle 9	Date In: _____ Time In: _____ Temperature: _____ °C Duration: _____ hours	Date In: _____ Time In: _____ Temperature: _____ °C Duration: _____ hours
Cycle 10	Date In: _____ Time In: _____ Temperature: _____ °C Duration: _____ hours	Date In: _____ Time In: _____ Temperature: _____ °C Duration: _____ hours

<b>Thermal protective aids</b>	Manufacturer: _____ Model: _____ Lot/Serial Number: _____	Date: _____ Time: _____ Surveyor: _____ Organization: _____																																				
<b>2.5.8 Test subjects</b>		<b>Regulations: LSA Code II/2.5.2; MSC.81(70) 1/3.3.4</b>																																				
Test Procedure	Acceptance Criteria	Significant Test Data																																				
For these tests a group of at least six test subjects of different ages, both male and female in the large, medium and small size range should be selected.	Test subject range:  <table style="width:100%; border:none;"> <tr> <td style="width:33%;">Height</td> <td style="width:67%;">Weight</td> </tr> <tr> <td>1.4 m – 1.6 m</td> <td>1 person under 60 kg 1 person over 60 kg</td> </tr> <tr> <td>1.6 m – 1.8 m</td> <td>1 person under 70 kg 1 person over 70 kg</td> </tr> <tr> <td>over 1.8 m</td> <td>1 person under 80 kg 1 person over 80 kg</td> </tr> </table>	Height	Weight	1.4 m – 1.6 m	1 person under 60 kg 1 person over 60 kg	1.6 m – 1.8 m	1 person under 70 kg 1 person over 70 kg	over 1.8 m	1 person under 80 kg 1 person over 80 kg	Comments/Observations  <table style="width:100%; border:none;"> <tr> <td style="width:33%;"></td> <td style="width:16.6%;">Male/Female</td> <td style="width:16.6%;">Height</td> <td style="width:16.6%;">Weight</td> </tr> <tr> <td>Subject 1</td> <td>_____</td> <td>_____</td> <td>_____</td> </tr> <tr> <td>Subject 2</td> <td>_____</td> <td>_____</td> <td>_____</td> </tr> <tr> <td>Subject 3</td> <td>_____</td> <td>_____</td> <td>_____</td> </tr> <tr> <td>Subject 4</td> <td>_____</td> <td>_____</td> <td>_____</td> </tr> <tr> <td>Subject 5</td> <td>_____</td> <td>_____</td> <td>_____</td> </tr> <tr> <td>Subject 6</td> <td>_____</td> <td>_____</td> <td>_____</td> </tr> </table>		Male/Female	Height	Weight	Subject 1	_____	_____	_____	Subject 2	_____	_____	_____	Subject 3	_____	_____	_____	Subject 4	_____	_____	_____	Subject 5	_____	_____	_____	Subject 6	_____	_____	_____
Height	Weight																																					
1.4 m – 1.6 m	1 person under 60 kg 1 person over 60 kg																																					
1.6 m – 1.8 m	1 person under 70 kg 1 person over 70 kg																																					
over 1.8 m	1 person under 80 kg 1 person over 80 kg																																					
	Male/Female	Height	Weight																																			
Subject 1	_____	_____	_____																																			
Subject 2	_____	_____	_____																																			
Subject 3	_____	_____	_____																																			
Subject 4	_____	_____	_____																																			
Subject 5	_____	_____	_____																																			
Subject 6	_____	_____	_____																																			
<b>2.5.9 Test clothing</b>		<b>Regulations: LSA Code II/2.5; MSC.81(70) 1/3.3.5, 3.2.6 &amp; 3.2.8</b>																																				
Test Procedure	Acceptance Criteria	Significant Test Data																																				
The test subjects should wear a standard range clothing consisting of  .1 underwear (short sleeved, short legged) .2 shirt (long sleeved) .3 trousers (not woollen, and woollen socks) .4 in addition to the clothing the test subjects should wear two woollen pullovers during the tests prescribed in 2.5.10; 2.5.11 and 2.5.12.		Did all test subject use the specified test clothing  <input type="checkbox"/> YES <input type="checkbox"/> NO  Comments/Observations																																				



<b>Thermal protective aids</b>	Manufacturer: _____ Model: _____ Lot/Serial Number: _____	Date: _____ Time: _____ Surveyor: _____ Organization: _____																
<b>2.5.10 Donning test (1)</b>		<b>Regulations: LSA Code II/2.5.2.; MSC.81(70) 1/3.3.6</b>																
Test Procedure	Acceptance Criteria	Significant Test Data																
Following a demonstration, the test subjects should be able to unpack and don the thermal protection aids over a lifejacket when seated in a survival craft or a rescue boat.	The test subjects should be able to unpack and don the thermal protection aid.	<table style="width:100%; border:none;"> <tr> <td style="text-align:center">TimePassed</td> <td style="text-align:center">Failed</td> </tr> <tr> <td>Subject No.1 _____ sec</td> <td>_____</td> </tr> <tr> <td>Subject No.2 _____ sec</td> <td>_____</td> </tr> <tr> <td>Subject No.3 _____ sec</td> <td>_____</td> </tr> <tr> <td>Subject No.4 _____ sec</td> <td>_____</td> </tr> <tr> <td>Subject No.5 _____ sec</td> <td>_____</td> </tr> <tr> <td>Subject No.6 _____ sec</td> <td>_____</td> </tr> <tr> <td colspan="2">Comments/Observations</td> </tr> </table>	TimePassed	Failed	Subject No.1 _____ sec	_____	Subject No.2 _____ sec	_____	Subject No.3 _____ sec	_____	Subject No.4 _____ sec	_____	Subject No.5 _____ sec	_____	Subject No.6 _____ sec	_____	Comments/Observations	
TimePassed	Failed																	
Subject No.1 _____ sec	_____																	
Subject No.2 _____ sec	_____																	
Subject No.3 _____ sec	_____																	
Subject No.4 _____ sec	_____																	
Subject No.5 _____ sec	_____																	
Subject No.6 _____ sec	_____																	
Comments/Observations																		
<b>2.5.11 Donning test (2) at low temperature</b>		<b>Regulations: LSA Code II/2.5.3; MSC.81(70) 1/3.3.7</b>																
Test Procedure	Acceptance Criteria	Significant Test Data																
The thermal protective aid should be capable of being unpacked and donned at an ambient temperature of -30° C. Before the donning test the thermal protective aid should be kept in a refrigerated chamber at a temperature of -30°C for 24 h.	<p>The test subjects should be able to successfully unpack and don the thermal protective aid without assistance in a survival craft or rescue boat.</p> <p>The thermal protective aid shall function properly throughout an air temperature range of -30°C to +20°C.</p>	<table style="width:100%; border:none;"> <tr> <td style="text-align:center">TimePassed</td> <td style="text-align:center">Failed</td> </tr> <tr> <td>Subject No.1 _____ sec</td> <td>_____</td> </tr> <tr> <td>Subject No.2 _____ sec</td> <td>_____</td> </tr> <tr> <td>Subject No.3 _____ sec</td> <td>_____</td> </tr> <tr> <td>Subject No.4 _____ sec</td> <td>_____</td> </tr> <tr> <td>Subject No.5 _____ sec</td> <td>_____</td> </tr> <tr> <td>Subject No.6 _____ sec</td> <td>_____</td> </tr> <tr> <td colspan="2">Comments/Observations</td> </tr> </table>	TimePassed	Failed	Subject No.1 _____ sec	_____	Subject No.2 _____ sec	_____	Subject No.3 _____ sec	_____	Subject No.4 _____ sec	_____	Subject No.5 _____ sec	_____	Subject No.6 _____ sec	_____	Comments/Observations	
TimePassed	Failed																	
Subject No.1 _____ sec	_____																	
Subject No.2 _____ sec	_____																	
Subject No.3 _____ sec	_____																	
Subject No.4 _____ sec	_____																	
Subject No.5 _____ sec	_____																	
Subject No.6 _____ sec	_____																	
Comments/Observations																		

<b>Thermal protective aids</b>	Manufacturer: _____ Model: _____ Lot/Serial Number: _____	Date: _____ Time: _____ Surveyor: _____ Organization: _____																																
<b>2.5.12 Discarding Test</b>		<b>Regulations: LSA Code II/2.5; MSC.81(70) 1/3.3.8</b>																																
Test Procedure	Acceptance Criteria	Significant Test Data																																
If the thermal protective aid impairs the ability of the test subjects to swim, it should be demonstrated that it can be discarded by the test subjects, when immersed in water, in not more than 2 min.	The test subject should be able to complete this task in less than 2 min.	<table style="width:100%; border:none;"> <tr> <td style="width:60%;"></td> <td style="text-align:center">TimePassed</td> <td style="text-align:center">Failed</td> <td></td> </tr> <tr> <td>Subject No.1</td> <td style="text-align:center">_____ sec</td> <td style="text-align:center">_____</td> <td style="text-align:center">_____</td> </tr> <tr> <td>Subject No.2</td> <td style="text-align:center">_____ sec</td> <td style="text-align:center">_____</td> <td style="text-align:center">_____</td> </tr> <tr> <td>Subject No.3</td> <td style="text-align:center">_____ sec</td> <td style="text-align:center">_____</td> <td style="text-align:center">_____</td> </tr> <tr> <td>Subject No.4</td> <td style="text-align:center">_____ sec</td> <td style="text-align:center">_____</td> <td style="text-align:center">_____</td> </tr> <tr> <td>Subject No.5</td> <td style="text-align:center">_____ sec</td> <td style="text-align:center">_____</td> <td style="text-align:center">_____</td> </tr> <tr> <td>Subject No.6</td> <td style="text-align:center">_____ sec</td> <td style="text-align:center">_____</td> <td style="text-align:center">_____</td> </tr> <tr> <td colspan="4" style="padding-top:10px;">Comments/Observations</td> </tr> </table>		TimePassed	Failed		Subject No.1	_____ sec	_____	_____	Subject No.2	_____ sec	_____	_____	Subject No.3	_____ sec	_____	_____	Subject No.4	_____ sec	_____	_____	Subject No.5	_____ sec	_____	_____	Subject No.6	_____ sec	_____	_____	Comments/Observations			
	TimePassed	Failed																																
Subject No.1	_____ sec	_____	_____																															
Subject No.2	_____ sec	_____	_____																															
Subject No.3	_____ sec	_____	_____																															
Subject No.4	_____ sec	_____	_____																															
Subject No.5	_____ sec	_____	_____																															
Subject No.6	_____ sec	_____	_____																															
Comments/Observations																																		
<b>2.5.13 Oil resistance test</b>		<b>Regulations: LSA Code I/1.2.2.4; MSC.81(70) 1/3.3.9</b>																																
Test Procedure	Acceptance Criteria	Significant Test Data																																
<p>After all its apertures have been sealed, a thermal protective aid should be immersed under 100 mm head of diesel oil for 24 h.</p> <p>The surface oil should then be wiped off and it should be established the thermal conductance of the material.</p>	After this test the thermal protective aid should show no signs of damage, such as shrinking, cracking, swelling, dissolution or change of mechanical qualities. The thermal conductance should be not more than 7800 W/m <sup>2</sup> K.	<p>Is the thermal conductance of the thermal protective aid not more than 7800 W/m<sup>2</sup> K?</p> <p style="text-align:right;"><input type="checkbox"/>YES <input type="checkbox"/>NO</p> <p>Is there any sign of damage, such as shrinking, cracking, swelling, dissolution or change of mechanical qualities?</p> <p style="text-align:right;"><input type="checkbox"/>YES <input type="checkbox"/>NO</p> <p>Comments/Observations</p>																																